

DESPIECE

DISASSEMBLY

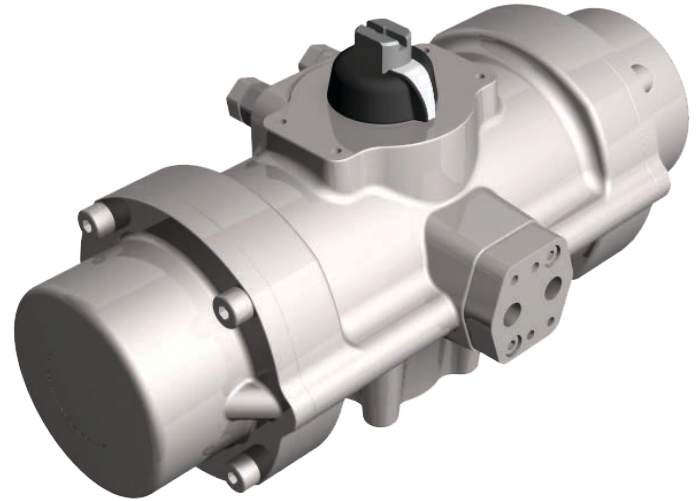

ACTUADOR NEUMÁTICO DE ACERO
INOXIDABLE **CF8M**
CF8M STAINLESS STEEL
PNEUMATIC ACTUATOR



PI20: Doble Efecto / Double Acting

PI20S: Simple Efecto / Spring Return

Nº	Descripción Description	Cant. Quant.	Material Material
1	TORNILLO ALLEN TAPA CAP ALLEN SCREW	8	ACERO INOX. AISI-316 AISI-316 STAINLESS STEEL
2	TAPA CAP	2	ACERO INOXIDABLE CF8M CF8M STAINLESS STEEL
3	JUNTA TÓRICA TAPA CAP-O-RING	2	N.B.R. N.B.R.
4	ÉMBOLO PISTON	2	POLIARILAMIDA POLYARILAMIDE
5	CILINDRO CYLINDER	1	ACERO INOXIDABLE CF8M CF8M STAINLESS STEEL
6	ARANDELA WASHER	1	POLIAMIDA 6 POLYAMIDE 6
7	ANILLO DE SEGURIDAD SPRING CLIP	1	ACERO INOXIDABLE STAINLESS STEEL
8	INDICADOR VISUAL POSITION INDICATOR	1	POLIAMIDA POLYAMIDE
9	GUIA ÉMBOLO PISTON GUIDE	2	POLIACETAL POLYACETAL
10	ANILLO GUIA GUIDE RING	2	POLIACETAL POLYACETAL
11	JUNTA TÓRICA ÉMBOLO PISTON O-RING	2	N.B.R. N.B.R.
12	JUNTA TÓRICA EJE SHAFT O-RING	2	N.B.R. N.B.R.
13	JUNTA TÓRICA EJE SHAFT O-RING	2	N.B.R. N.B.R.
14	JUEGO MUELLES PRECARGADOS PRELOADED SPRINGS SET	1	DIN-17223-C (2) (4) DIN-17223-C (2) (4)
16	EJE SHAFT	1	ACERO INOX AISI-316 AISI-316 STAINLESS STEEL
17	PIÑÓN GEAR	1	ALEACIÓN ALUMINIO (5) (2) ALUMINIUM ALLOY (5) (2)
18	JUNTA TÓRICA PLACA PLATE O-RING	2	N.B.R. N.B.R.
19	JUNTA TÓRICA TAPA CAP O-RING	2	N.B.R. N.B.R.
20	PLACA CONEXIÓN NEUMÁTICA PNEUMATIC CONNECTION PLATE	1	ACERO INOXIDABLE CF8M CF8M STAINLESS STEEL
21	TORNILLO ALLEN PLACA PLATE ALLEN SCREW	2	ACERO INOXIDABLE AISI-316 AISI-316 STAINLESS STEEL
22	TORNILLO BOLT	2	ACERO INOXIDABLE AISI-316 AISI-316 STAINLESS STEEL
23	TUERCA NUT	2	ACERO INOXIDABLE AISI-316 AISI-316 STAINLESS STEEL
24	ARANDELA BUSHING	2	ACERO INOXIDABLE AISI-316 AISI-316 STAINLESS STEEL
25	JUNTA TÓRICA O-RING	2	N.B.R. N.B.R.
26	LEVA CAM	1	ACERO INOXIDABLE CF8 CF8 STAINLESS STEEL

- (2) RECUBRIMIENTO POR CATAFORESIS.
COVERED BY CATAPHORESIS.
- (4) CANTIDAD VARIABLE, CONSULTAR TABLAS PARES SIMPLE EFECTO.
VARIABLE QUANTITY, PLEASE SEE THE SPRING RETURN TORQUE CHART.
- (5) BRUÑIDO CON BOLAS.
BALL BURNISHING.

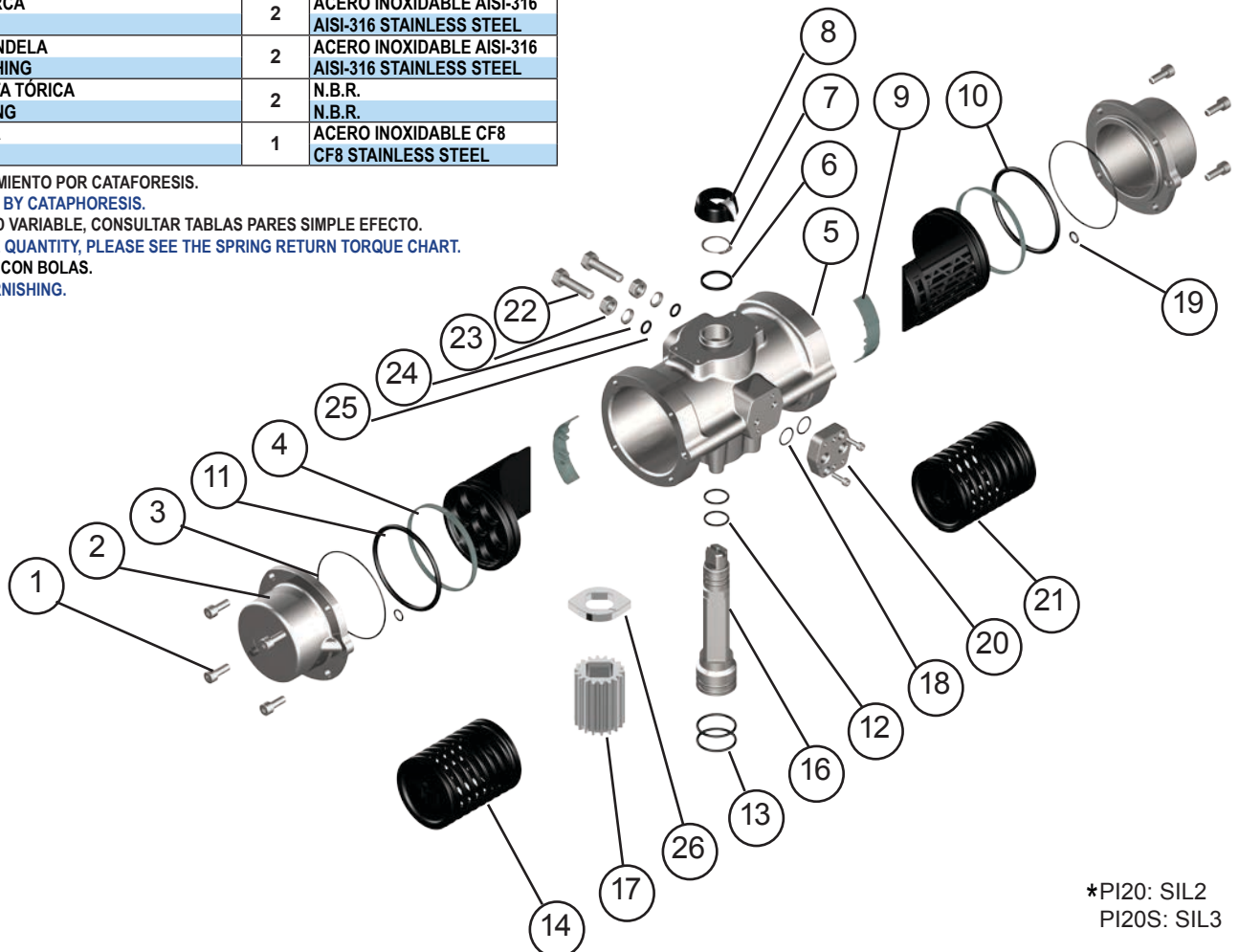

*PI20: SIL2
PI20S: SIL3

MODELOS MODELS	TIEMPO DE MANIOBRA EN SEG. CYCLE TIME IN SECS.		PESOS WEIGHTS		CAPACIDAD EN LITROS CAPACITY IN LITRES	
	PARA ABRIR TO OPEN	PARA CERRAR TO CLOSE	Kg.	Lb.	PARA ABRIR TO OPEN	PARA CERRAR TO CLOSE
PI20	0,4	0,4	5,9	13,01	0,8	0,7
PI20S	0,5	0,5	9,9	21,83	0,8	

Tiempo de maniobra sin par resistente a 6 bar.
Cycle time w/o resistant torque at 6 bar.

Dimensiones en mm.
Dimensions in mm.

Para calcular el consumo, multiplicar las cifras del cuadro por la presión real de trabajo.

To calculate the consumption, multiply the above figures by the real working pressure.

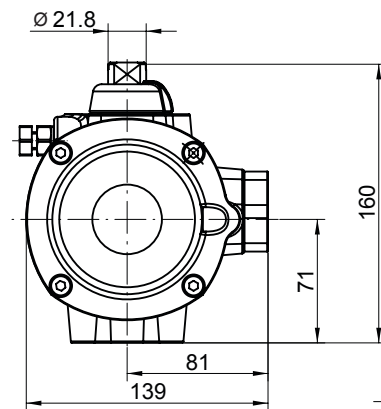
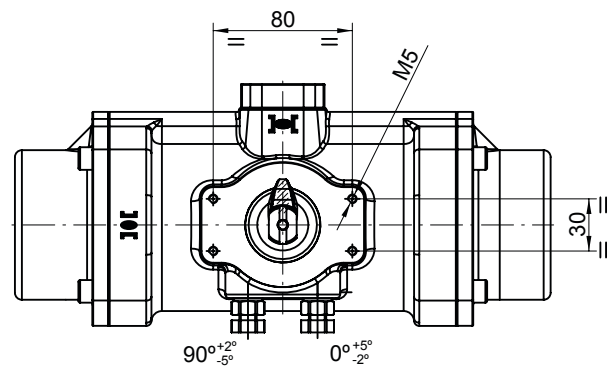
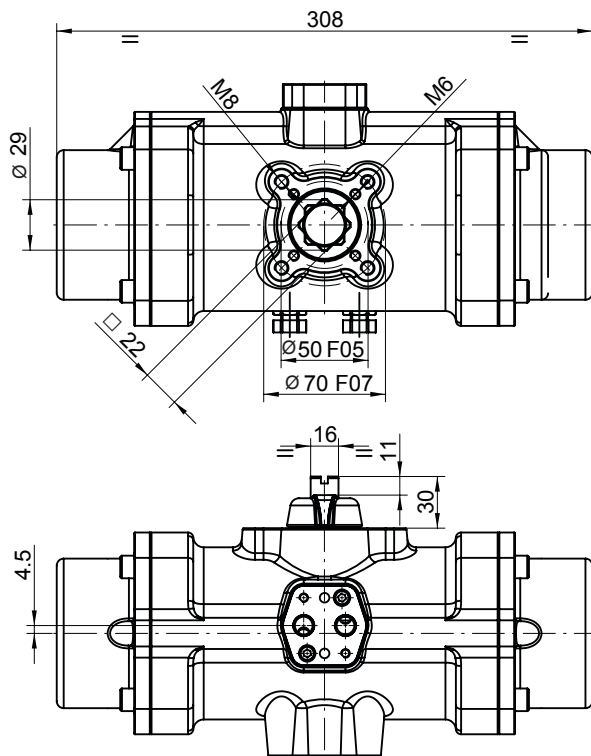

PARES DOBLE EFECTO DOUBLE ACTING TORQUES

PI20	PRESION AIRE AIR PRESSURE							
bar	3	4	4,5	5	5,5	6	7	8
p.s.i	43,5	58	65,3	72,5	79,8	87	101,5	116
Nm	77,7	107	121,7	136,3	150,9	165,5	194,8	224
Lb.in	687,8	947,3	1.078	1.206	1.335	1.465	1.724	1.983

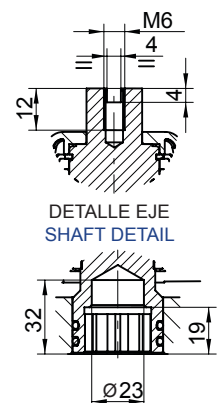
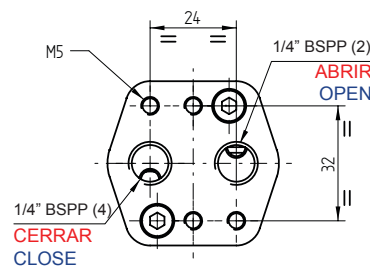

PARES SIMPLE EFECTO SPRING RETURN TORQUES

PI20S	PAR MUELLES SPRING TORQUES		PAR A LA PRESIÓN INDICADA AIR TORQUE AT INDICATED PRESSURE																
			3		4		4,5		5		5,5		6		7		8		bar
N	INICIAL INITIAL	FINAL END	INICIAL INITIAL	FINAL END	INICIAL INITIAL	FINAL END	INICIAL INITIAL	FINAL END	INICIAL INITIAL	FINAL END	INICIAL INITIAL	FINAL END	INICIAL INITIAL	FINAL END	INICIAL INITIAL	FINAL END	INICIAL INITIAL	FINAL END	p.s.i
3	104,7	65,8					55,9	17	70,5	32	85,1	46,4	99,7	60,8	129	90,1	158,2	119	Nm
	927	582,3					494,4	149,7	623,8	279,6	753,4	409,1	882,9	538,6	1142	797,5	1400	1056	Lb.in
2	71,8	44,9			62,1	35,2	76,8	49,9	91,4	64,5	106	79,1	120,6	93,7	149,9	123	179	152	Nm
	635,4	397,4			549,9	311,9	679,3	441,3	808,8	570,7	938,6	700,3	1068	829,8	1327	1088	1585	1347	Lb.in
1	49,7	32,9	44,8	29,8	74,1	59,1	88,8	72	103,4	88,4	118	103	132,6	117,6	161,9	146,9	191	176,1	Nm
	423,9	291,2	396,7	263,9	656,1	523,4	785,5	652,8	915	782,3	1044	911,3	1174	1041	1433	1300	1691	1559	Lb.in

N: Número de muelles por banda
Number of springs per side

* Número de muelles estándar
* Standard number of springs