

DESPIECE

DISASSEMBLY



ACTUADOR NEUMÁTICO DE ALUMINIO
ALUMINIUM PNEUMATIC ACTUATOR



PA60: Doble Efecto / Double Acting

PA60S: Simple Efecto / Spring Return

Nº	Descripción Description	Cant. Quant.	Material Material
1	TORNILLO ALLEN TAPA CAP ALLEN SCREW	16	ACERO INOXIDABLE AISI-304 AISI-304 STAINLESS STEEL
2	TAPA CAP	2	ALEACIÓN ALUMINIO (2) + (1) ALUMINIUM ALLOY (2) + (1)
3	JUNTA TÓRICA TAPA CAP-O-RING	2	N.B.R. N.B.R.
4	ÉMBOLO PISTON	2	ALEACIÓN ALUMINIO ALUMINIUM ALLOY
5	CILINDRO CYLINDER	1	ALEACIÓN ALUMINIO (2) + (1) ALUMINIUM ALLOY (2) + (1)
6	ARANDELA WASHER	1	POLIAMIDA 6 POLYAMIDA 6
7	ANILLO DE SEGURIDAD SPRING CLIP	1	ACERO (2) STEEL (2)
8	INDICADOR VISUAL POSITION INDICATOR	1	POLIAMIDA POLYAMIDE
9	GUIA ÉMBOLO PISTON GUIDE	4	P.F.T.E + CARBONO P.F.T.E + CARBON
10	ANILLO GUIA GUIDE RING	2	P.T.F.E + BRONCE P.T.F.E + BRONZE
11	JUNTA TÓRICA ÉMBOLO PISTON O-RING	4	N.B.R. N.B.R.
12	JUNTA TÓRICA EJE SHAFT O-RING	2	N.B.R. N.B.R.
13	JUNTA TÓRICA EJE SHAFT O-RING	2	N.B.R. N.B.R.
14	MUELLES PRECARGADOS PRELOADED SPRINGS	12	DIN-17223-C (2) (4) DIN-17223-C (2) (4)
15	LEVA CAM	1	ACERO (2) STEEL (2)
16	EJE SHAFT	1	ACERO (2) STEEL (2)
17	JUNTA TÓRICA PLACA PLATE O-RING	2	N.B.R. N.B.R.
18	JUNTA TÓRICA TAPA CAP O-RING	2	N.B.R. N.B.R.
19	PLACA CONEXIÓN NEUMÁTICA PNEUMATIC CONNECTION PLATE	1	ACERO INOXIDABLE CF8M CF8M STAINLESS STEEL
20	TORNILLO ALLEN PLACA PLATE ALLEN SCREW	2	ACERO INOXIDABLE AISI-304 AISI-304 STAINLESS STEEL
21	TORNILLO HEXAGONAL HEXAGONAL SCREW	2	ACERO (3) STEEL (3)
22	TUERCA NUT	2	ACERO INOX. AISI-304 AISI-304 STAINLESS STEEL
23	ARANDELA BUSHING	2	ACERO INOXIDABLE AISI-303 AISI-303 STAINLESS STEEL
24	JUNTA TÓRICA O-RING	2	N.B.R. N.B.R.
25	PIÑÓN GEAR	1	ALEACION DE ALUMINIO (5) ALUMINIUM ALLOY (5)
26	ARANDELA WASHER	16	ACERO INOX. AISI-304 AISI-304 STAINLESS STEEL
27	ARGOLLA HOOP	2	ACERO INOX. AISI-304 AISI-304 STAINLESS STEEL

- (1) RECUBRIMIENTO CON POLIAMIDA.
COVERED WITH POLYAMIDE.
- (2) RECUBRIMIENTO POR CATAFORESIS.
COVERED BY CATHAPHORESIS.
- (3) PASIVADO DE CROMO TRIVALENTE.
TRIVALENT Cr PASSIVATION.
- (4) CANTIDAD VARIABLE, CONSULTAR
TABLAS PARES SIMPLE EFECTO.
VARIABLE QUANTITY, PLEASE SEE THE
SPRING RETURN TORQUE CHART.
- (5) BRUÑIDO CON BOLAS.
BALL BURNISHING.

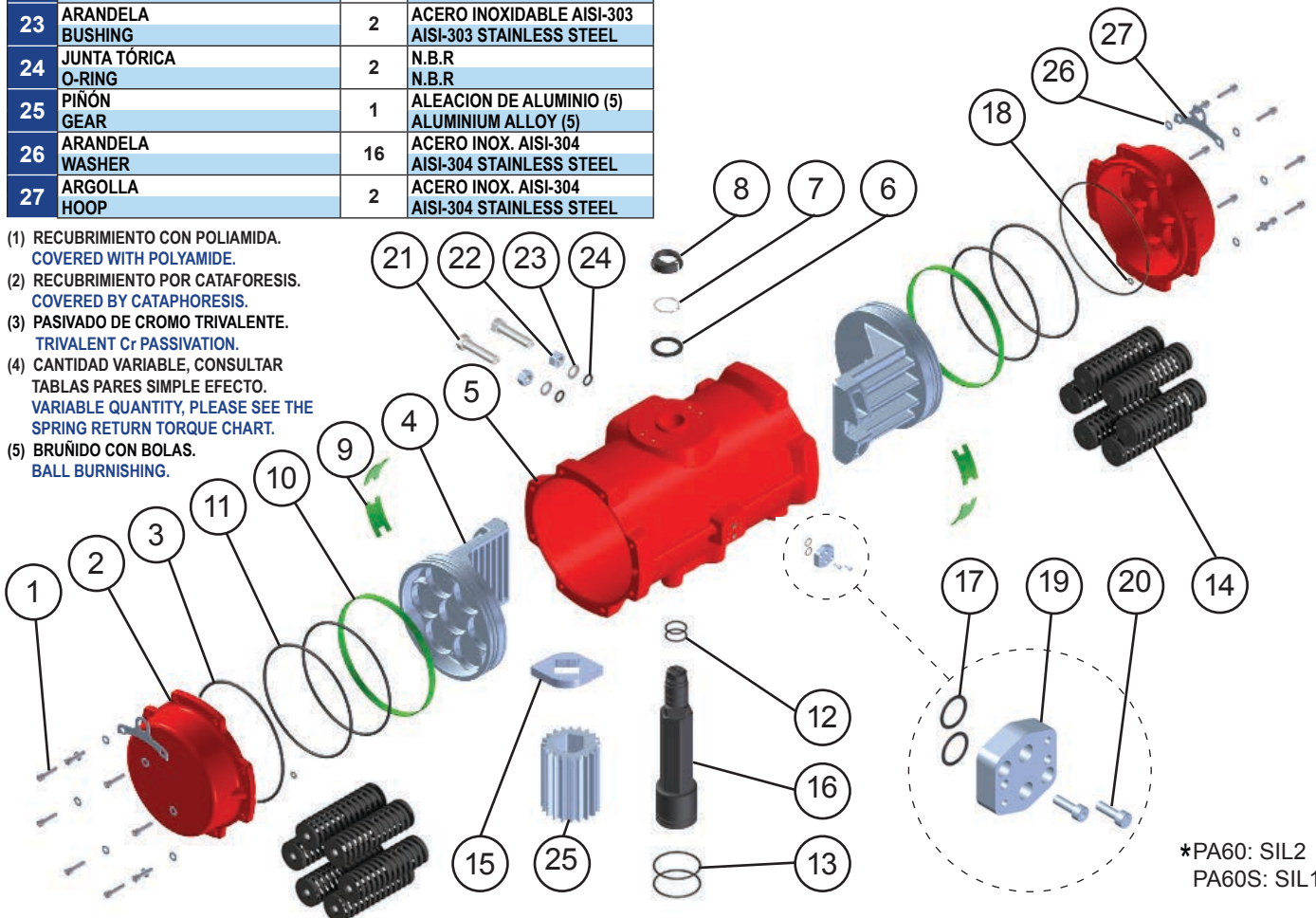

*PA60: SIL2
PA60S: SIL1

MODELOS MODELS	TIEMPO DE MANIOBRA EN SEG. CYCLE TIME IN SECS.		PESOS WEIGHTS		CAPACIDAD EN LITROS CAPACITY IN LITRES	
	PARA ABRIR TO OPEN	PARA CERRAR TO CLOSE	Kg.	Lb.	PARA ABRIR TO OPEN	PARA CERRAR TO CLOSE
PA60	3	3	48,3	106,48	19,5	20,7
PA60S	6	5	83,2	183,41	19,5	

Tiempo de maniobra sin par resistente a 6 bar.
Cycle time w/o resistant torque at 6 bar.

Dimensiones en mm.
Dimensions in mm.

Para calcular el consumo, multiplicar las cifras del cuadro por la presión real de trabajo.

To calculate the consumption, multiply the above figures by the real working pressure.

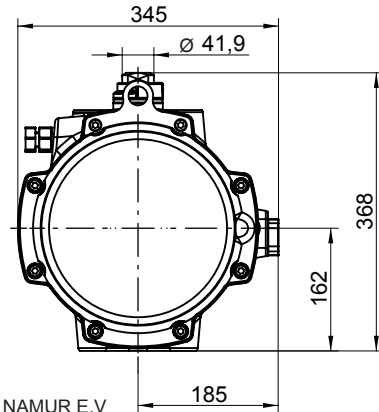
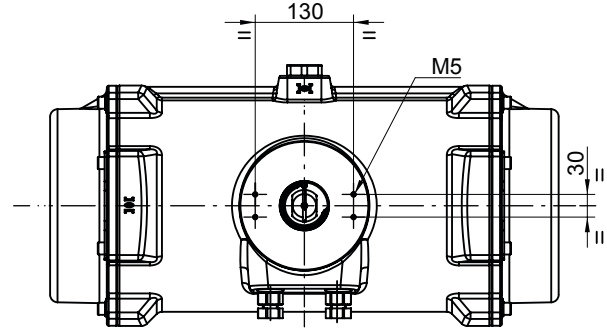
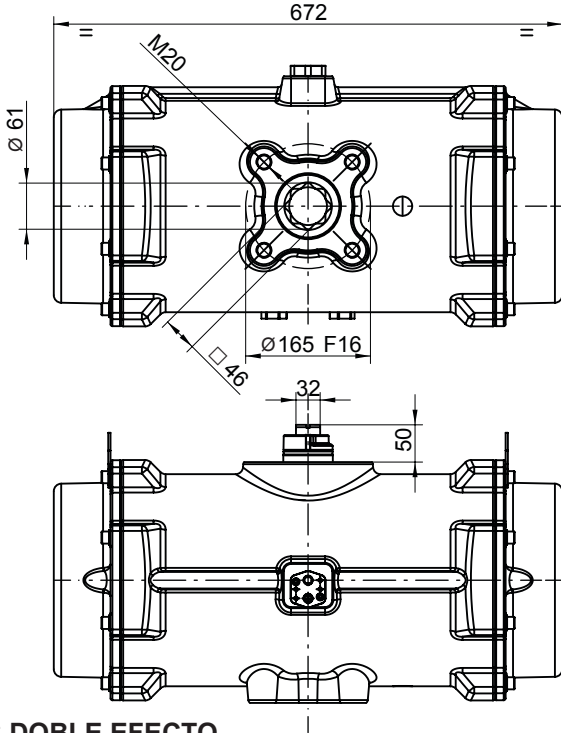

NORMA NAMUR E.V
SOLENOID NAMUR NORM

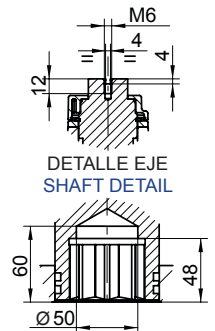
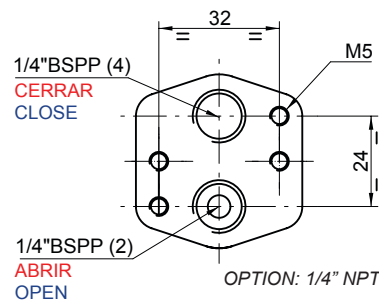

PARES DOBLE EFECTO DOUBLE ACTING TORQUES

PA60	PRESION AIRE AIR PRESSURE							
bar	3	4	4,5	5	5,5	6	7	8
p.s.i	43,5	58	65,3	72,5	79,8	87	101,5	116
Nm	1.638	2.245	2.548	2.851	3.155	3.458	4.065	4.672
Lb.in	14.497	19.870	22.551	25.233	27.924	30.606	35.978	41.351

PARES SIMPLE EFECTO SPRING RETURN TORQUES

PA60S	PAR MUELLES SPRING TORQUES		PAR A LA PRESIÓN INDICADA AIR TORQUE AT INDICATED PRESSURE																
			3	4	4,5	5	5,5	6	7	8	bar								
				43,5	58	65,3	72,5	79,8	87	101,5	116	p.s.i							
N	INICIAL INITIAL	FINAL END	INICIAL INITIAL	FINAL END	INICIAL INITIAL	FINAL END	INICIAL INITIAL	FINAL END	INICIAL INITIAL	FINAL END	INICIAL INITIAL	FINAL END	INICIAL INITIAL	FINAL END	INICIAL INITIAL	FINAL END	INICIAL INITIAL	FINAL END	
6*	2.075	1.383							1.468	776	1.772	1.080	2.075	1.383	2.682	1.990	3.289	2.597	Nm
	18.365	12.241							12.993	6.868	15.683	9.559	18.365	12.241	23.738	17.613	29.110	22.985	Lb.in
5	1.729	1.153					1.395	819	1.698	1.122	2.002	1.426	2.305	1.729	2.912	2.336	3.519	2.943	Nm
	15.303	10.205					12.346	7.248	15.029	9.931	17.719	12.621	20.401	15.303	25.773	20.675	31.146	26.048	Lb.in
4	1.383	922			1.323	862	1.626	1.165	1.929	1.468	2.233	1.772	2.536	2.075	3.143	2.682	3.750	3.289	Nm
	12.241	8.160			11.710	7.629	14.391	10.310	17.073	12.993	19.764	15.683	22.445	18.365	27.818	23.738	33.190	29.110	Lb.in
3	1.037	692	946	601	1.553	1.208	1.856	1.511	2.159	1.814	2.463	2.118	2.766	2.421	3.373	3.028			Nm
	9.178	6.125	8.373	5.319	13.745	10.692	16.426	13.373	19.109	16.055	21.799	18.746	24.481	21.428	29.854	26.800			Lb.in
2	692	462	1.176	946	1.783	1.553	2.086	1.856	2.389	2.159	2.693	2.463	2.996	2.766					Nm
	6.125	4.089	10.408	8.373	15.781	13.745	18.462	16.426	21.144	19.109	23.835	21.799	24.481	24.481					Lb.in

N: Número de muelles por banda
Number of springs per side

* Número de muelles estándar
* Standard number of springs