

DESPIECE

DISASSEMBLY

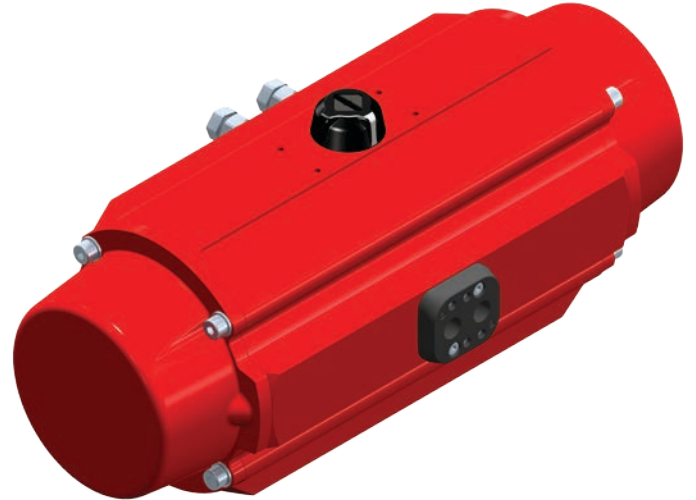

ACTUADOR NEUMÁTICO DE ALUMINIO
ALUMINIUM PNEUMATIC ACTUATOR



PA30: Doble Efecto / Double Acting

PA30S: Simple Efecto / Spring Return

Nº	Descripción Description	Cant. Quant.	Material Material
1	TORNILLO ALLEN TAPA CAP ALLEN SCREW	8	ACERO INOXIDABLE AISI-304 AISI-304 STAINLESS STEEL
2	TAPA CAP	2	ALEACIÓN ALUMINIO (2) + (7) ALUMINIUM ALLOY (2) + (7)
3	JUNTA TÓRICA TAPA CAP-O-RING	2	N.B.R. N.B.R.
4	ÉMBOLO PISTON	2	ALEACIÓN ALUMINIO (2) ALUMINIUM ALLOY (2)
5	CILINDRO CYLINDER	1	ALEACIÓN ALUMINIO (2) + (1) ALUMINIUM ALLOY (2) + (1)
6	ARANDELA WASHER	1	POLIACETAL POLYACETAL
7	ANILLO DE SEGURIDAD SPRING CLIP	1	ACERO (3) STEEL (3)
8	INDICADOR VISUAL POSITION INDICATOR	1	POLIAMIDA POLYAMIDE
9	GUIA ÉMBOLO PISTON GUIDE	2	POLIACETAL + Mb POLYACETAL + Mb
10	ANILLO GUIA GUIDE RING	2	POLIACETAL POLYACETAL
11	JUNTA TÓRICA ÉMBOLO PISTON O-RING	4	N.B.R. N.B.R.
12	JUNTA TÓRICA EJE SHAFT O-RING	2	N.B.R. N.B.R.
13	JUNTA TÓRICA EJE SHAFT O-RING	2	N.B.R. N.B.R.
14	MUELLES PRECARGADOS PRELOADED SPRINGS	12	DIN-17223-C (2) (4) DIN-17223-C (2) (4)
15	LEVA CAM	1	ACERO (2) STEEL (2)
16	EJE SHAFT	1	ACERO (2) STEEL (2)
17	JUNTA TÓRICA PLACA PLATE O-RING	2	N.B.R. N.B.R.
18	TUERCA NUT	4	ACERO INOXIDABLE AISI-304 AISI-304 STAINLESS STEEL
19	PLACA CONEXIÓN NEUMÁTICA PNEUMATIC CONNECTION PLATE	1	POLIAMIDA + FV POLYAMIDE + FG
20	TORNILLO ALLEN PLACA PLATE ALLEN SCREW	2	ACERO INOXIDABLE AISI-304 AISI-304 STAINLESS STEEL
21	TORNILLO HEXAGONAL HEXAGONAL SCREW	2	ACERO INOXIDABLE AISI-304 AISI-304 STAINLESS STEEL
22	TUERCA NUT	2	ACERO INOXIDABLE AISI-304 AISI-304 STAINLESS STEEL
23	ARANDELA BUSHING	2	ACERO INOXIDABLE AISI-316 AISI-316 STAINLESS STEEL
24	JUNTA TÓRICA O-RING	2	N.B.R. N.B.R.
25	PIÑÓN GEAR	1	ALEACIÓN ALUMINIO (5) ALUMINIUM ALLOY (5)
26	ARANDELA TAPA CAP WASHER	8	ACERO INOXIDABLE AISI-304 AISI-304 STAINLESS STEEL
27	JUNTA PLANA WATERTIGHTNESS PLANE GASKET	2	NEOPRENO NEOPRENE

- (1) RECUBRIMIENTO CON POLIAMIDA.
COVERED WITH POLYAMIDE.
- (2) RECUBRIMIENTO POR CATAFORESIS.
COVERED BY CATAPHORESIS.
- (3) RECUBIERTO CON NÍQUEL-TEFLON.
COVERED BY NIKEL-P.T.F.E.
- (4) CANTIDAD VARIABLE, CONSULTAR
TABLAS PARES SIMPLE EFECTO.
VARIABLE QUANTITY, PLEASE SEE THE
SPRING RETURN TORQUE CHART.
- (5) BRUÑIDO CON BOLAS.
BALL BURNISHING.
- (7) RECUBRIMIENTO CON POLIURETANO.
COVERED WITH POLYURETHANE.

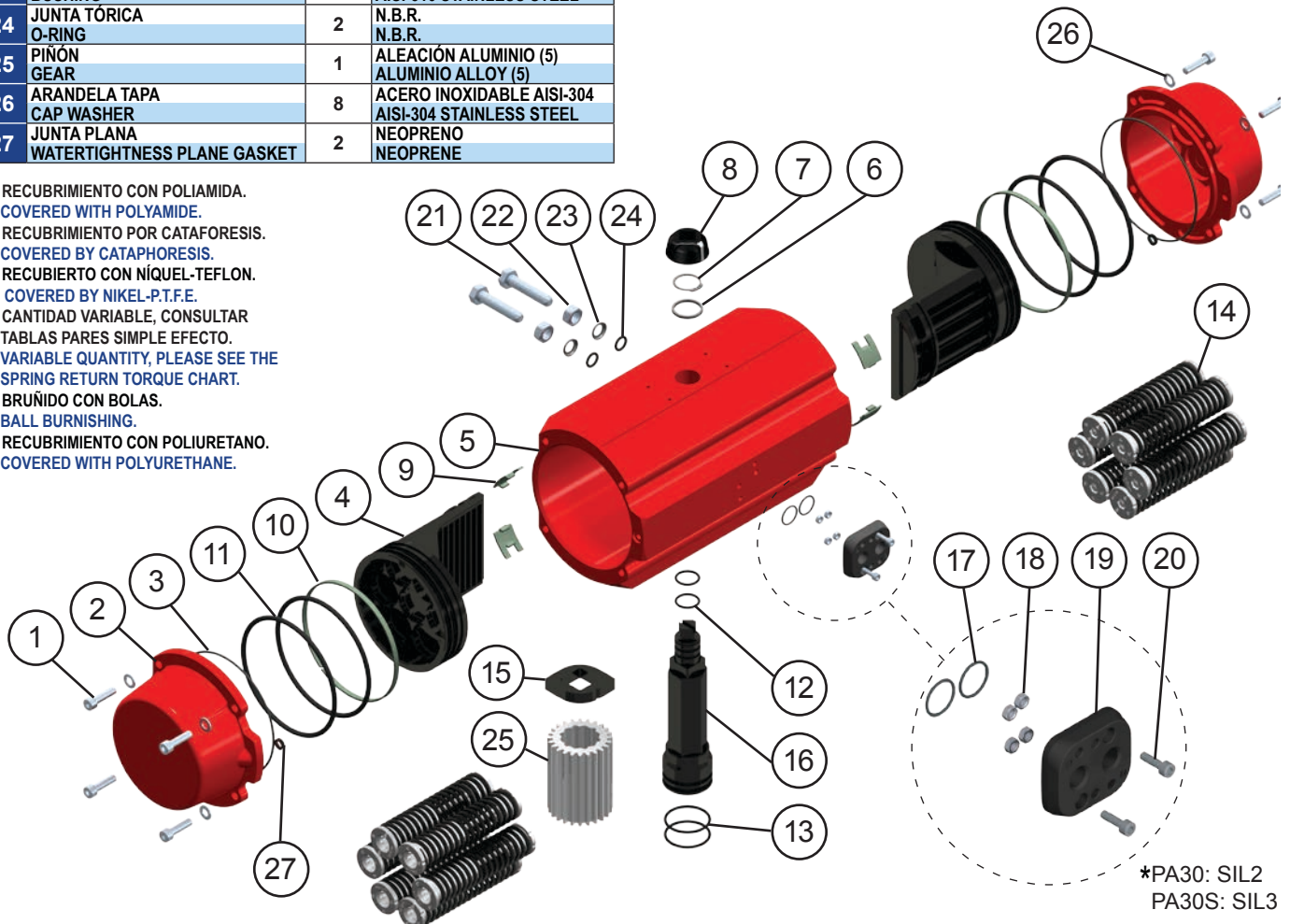

*PA30: SIL2
PA30S: SIL3

MODELOS MODELS	TIEMPO DE MANIOBRA EN SEG. CYCLE TIME IN SECS.		PESOS WEIGHTS		CAPACIDAD EN LITROS CAPACITY IN LITRES	
	PARA ABRIR TO OPEN	PARA CERRAR TO CLOSE	Kg.	Lb.	PARA ABRIR TO OPEN	PARA CERRAR TO CLOSE
PA30	1,2	1,2	11,6	25,46	2,05	3
PA30S	2	2	15,3	33,64	2,05	

Tiempo de maniobra sin par resistente a 6 bar.
Cycle time w/o resistant torque at 6 bar.

Dimensiones en mm.
Dimensions in mm.

Para calcular el consumo, multiplicar las cifras del cuadro por la presión real de trabajo.

To calculate the consumption, multiply the above figures by the real working pressure.

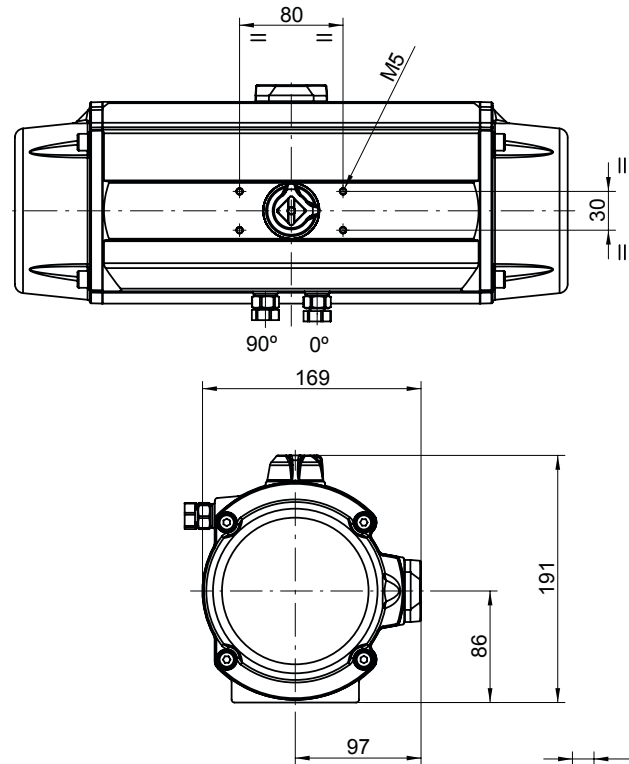
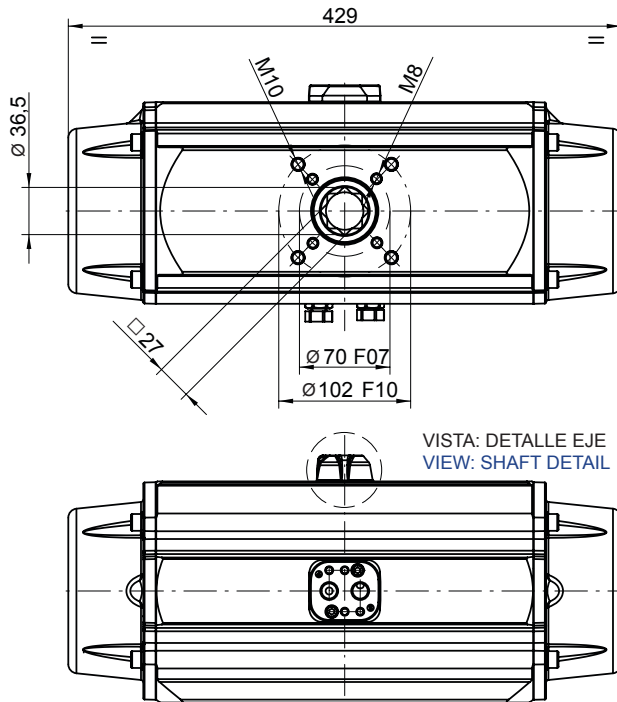

PA30 DOUBLE ACTING TORQUES

PA30	PRESION AIRE AIR PRESSURE							
bar	3	4	4,5	5	5,5	6	7	8
p.s.i	43,5	58	65,3	72,5	79,8	87	101,5	116
Nm	226,5	307,4	347,7	388	428,7	469	550,1	631
Lb.in	2.005	2.721	3.079	3.437	3.794	4.153	4.869	5.585

PA30S SPRING RETURN TORQUES

PA30S	PAR MUELLES SPRING TORQUES		PAR A LA PRESIÓN INDICADA AIR TORQUE AT INDICATED PRESSURE																
			3		4		4,5		5		5,5		6		7		8		bar
N	INICIAL INITIAL	FINAL END	INICIAL INITIAL	FINAL END	INICIAL INITIAL	FINAL END	INICIAL INITIAL	FINAL END	INICIAL INITIAL	FINAL END	INICIAL INITIAL	FINAL END	INICIAL INITIAL	FINAL END	INICIAL INITIAL	FINAL END	INICIAL INITIAL	FINAL END	p.s.i
6*	290,3	195,7					152	57,4	192,6	98	233	138,4	273,5	178,9	354,4	259,8	435,3	340,7	Nm
	2.569	1.732					1.347	510	1.705	867,4	2.062	1.225	2.421	1.583	3.137	2.299	3.853	3.015	Lb.in
5	241,9	163,1			144,2	65,4	184,6	105,8	225,1	146,2	265,5	186,7	306	227,1	386,8	308	467,7	388,8	Nm
	2141	1443			1.276	579	1.636	938	1.992	1.294	2.350	1.652	2.708	2.010	3.423	2.726	4.139	3.441	Lb.in
4	193,5	130,5	96,0	32,9	176,8	113,8	217,2	154,2	257,7	194,6	298,1	235,1	338,6	275,5	419,4	356,4	500,3	437,2	Nm
	1713	1155	849,3	291	1.565	1.007	1.924	1.366	2.281	1.722	2.639	2.080	2.996	2.438	3.712	3.154	4.428	3.870	Lb.in
3	145,2	97,9	128,6	81,3	209,5	162,1	249,8	202,5	290,3	243	330,8	283,4	371,2	323,9	452,1	404,8			Nm
	1285	866	1.138	719	1.854	1.435	2.213	1.794	2.569	2.151	2.927	2.509	3.285	2.866	4.001	3.582			Lb.in
2	96,8	65,2	161,2	129,7	242,1	210,5	282,5	250,9	322,9	291,4	363,4	331,8	403,8	372,3					Nm
	856,4	577,3	1.427	1.147	2.142	1.863	2.502	2.223	2.858	2.579	3.216	2.937	3.574	3.295					Lb.in

N: Número de muelles por banda
Number of springs per side

* Número de muelles estándar
* Standard number of springs

NORMA NAMUR E.V
SOLENOID NAMUR NORM

