

DESPIECE

DISASSEMBLY

Nº	Descripción Description	Cant. Quant.	Material Material
1	TORNILLO AVELLANADO TAPA CAP COUNTERSUNK SCREW	8	ACERO INOXIDABLE AISI-304 AISI-304 STAINLESS STEEL
2	TAPA CAP	2	ALEACIÓN ALUMINIO (2) + (7) ALUMINIUM ALLOY (2) + (7)
3	JUNTA TÓRICA TAPA CAP-O-RING	2	N.B.R. N.B.R.
4	EMBOLO PISTON	2	ALEACIÓN ALUMINIO (2) ALUMINIUM ALLOY (2)
5	CILINDRO CYLINDER	1	ALEACIÓN DE ALUMINIO (2) + (1) ALUMINIUM ALLOY (2) + (1)
6	ARANDELA WASHER	1	POLIACETAL POLYACETAL
7	ANILLO DE SEGURIDAD SPRING CLIP	1	ACERO INOXIDABLE STAINLESS STEEL
8	INDICADOR VISUAL POSITION INDICATOR	1	POLIAMIDA POLYAMIDE
9	GUIA EMBOLO PISTON GUIDE	2	POLIACETAL + Mb POLYACETAL + Mb
10	ANILLO GUIA GUIDE RING	2	POLIACETAL + Mb POLYACETAL + Mb
11	JUNTA TÓRICA EMBOLO PISTON O-RING	2	N.B.R. N.B.R.
12	JUNTA TÓRICA EJE SHAFT O-RING	2	N.B.R. N.B.R.
13	JUNTA TÓRICA EJE SHAFT O-RING	2	N.B.R. N.B.R.
14	MUELLES PRECARGADOS PRELOADED SPRINGS	12	DIN-17223-C (6) (4) DIN-17223-C (6) (4)
15	PLACA BASE (ISO-5211) BASE PLATE (ISO-5211)	1	POLIAMIDA + FV POLYAMIDE + FG
16	EJE SHAFT	1	ACERO (2) STEEL (2)
17	LEVA CAM	1	ACERO (2) STEEL (2)
18	TORNILLO ALLEN ALLEN SCREW	2	ACERO INOXIDABLE AISI-304 AISI-304 STAINLESS STEEL
19	TUERCA NUT	4	ACERO INOXIDABLE AISI-304 AISI-304 STAINLESS STEEL
20	JUNTA TÓRICA PLACA PLATE O-RING	2	N.B.R. N.B.R.
21	TUERCA NUT	4	ACERO INOXIDABLE AISI-304 AISI-304 STAINLESS STEEL
22	PLACA CONEXIÓN NEUMÁTICA PNEUMATIC CONNECTION PLATE	1	POLIAMIDA + FV POLYAMIDE + FG
23	TORNILLO ALLEN PLACA PLATE ALLEN SCREW	2	ACERO INOXIDABLE AISI-304 AISI-304 STAINLESS STEEL
24	TORNILLO HEXAGONAL HEXAGONAL SCREW	2	ACERO INOXIDABLE AISI-304 AISI-304 STAINLESS STEEL
25	TUERCA NUT	2	ACERO INOXIDABLE AISI-304 AISI-304 STAINLESS STEEL
26	ARANDELA BUSHING	2	ACERO INOXIDABLE AISI-304 AISI-304 STAINLESS STEEL
27	JUNTA TÓRICA O-RING	2	N.B.R. N.B.R.



ACTUADOR NEUMÁTICO DE ALUMINIO
ALUMINIUM PNEUMATIC ACTUATOR



PA00: Doble Efecto / Double Acting

PA00S: Simple Efecto / Spring Return

- (1) RECUBRIMIENTO CON POLIAMIDA.
COVERED WITH POLYAMIDE.
- (2) RECUBRIMIENTO POR CATAFORESIS.
COVERED BY CATAPHORESIS.
- (4) CANTIDAD VARIABLE, CONSULTAR
TABLAS PARES SIMPLE EFECTO.
VARIABLE QUANTITY, PLEASE SEE THE
SPRING RETURN TORQUE CHART.
- (6) PASIVADO DE CROMO TRIVALENTE.
TRIVALENT CHROMINIUM PASSIVATION.
- (7) RECUBRIMIENTO CON POLIURETANO.
COVERED WITH POLYURETHANE.

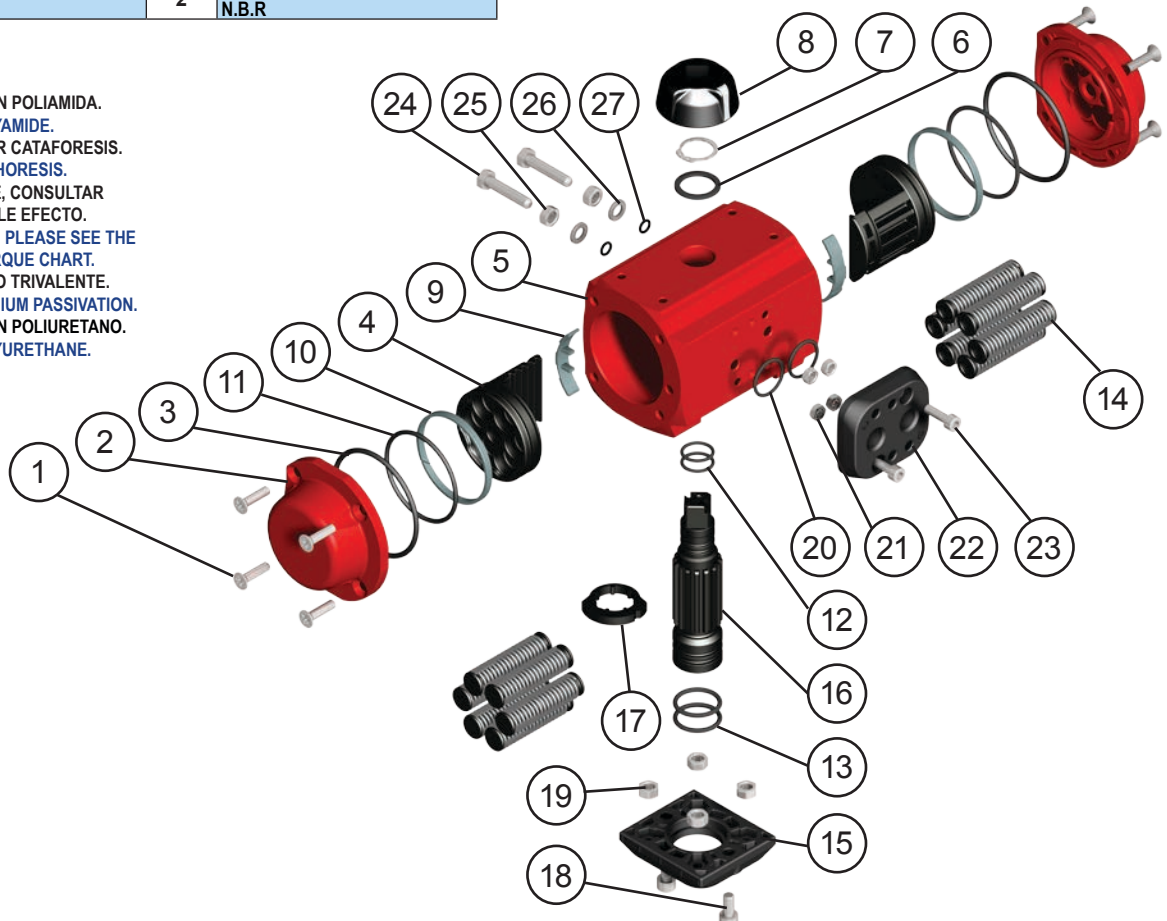

MODELOS MODELS	TIEMPO DE MANIOBRA EN SEG. CYCLE TIME IN SECS.		PESOS WEIGHTS		CAPACIDAD EN LITROS CAPACITY IN LITRES	
	PARA ABRIR TO OPEN	PARA CERRAR TO CLOSE	Kg.	Lb.	PARA ABRIR TO OPEN	PARA CERRAR TO CLOSE
PA00	0,15	0,15	1,40	3,09	0,15	0,18
PA00S	0,2	0,2	1,625	3,58	0,15	

Tiempo de maniobra sin par resistente a 6 bar.
Cycle time w/o resistant torque at 6 bar.

Dimensiones en mm.
Dimensions in mm.

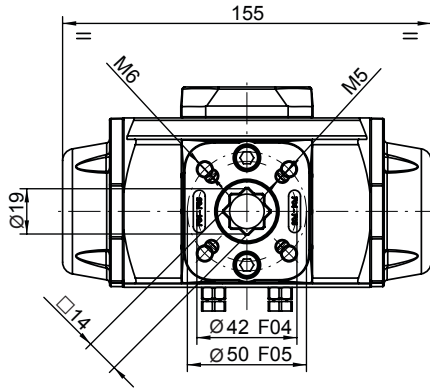

Para calcular el consumo, multiplicar las cifras del cuadro por la presión real de trabajo.

To calculate the consumption, multiply the above figures by the real working pressure.

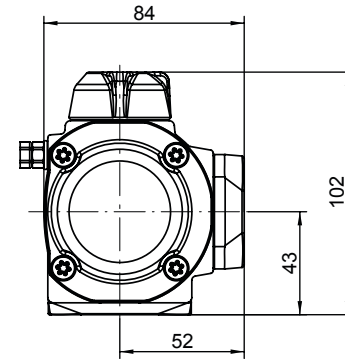
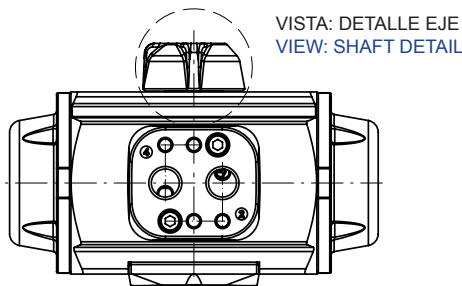
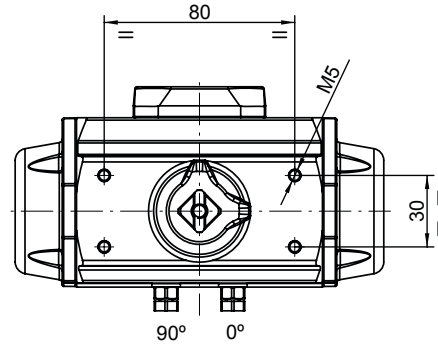

PA00 DOUBLE ACTING TORQUES

PA00	PRESION AIRE AIR PRESSURE							
bar	3	4	4,5	5	5,5	6	7	8
p.s.i	43,5	58	65,3	72,5	79,8	87	101,5	116
Nm	13,3	18,3	20,9	23,4	26	28,5	33,6	38,7
Lb.in	117,7	162	184,6	207,1	230,1	252,2	297,4	342,5

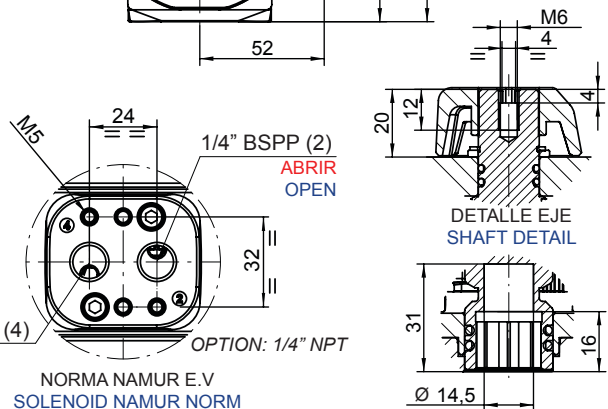

PA00S SPRING RETURN TORQUES

PA00S	PAR MUELLES SPRING TORQUES		PAR A LA PRESIÓN INDICADA AIR TORQUE AT INDICATED PRESSURE																	
			3		4		4,5		5		5,5		6		7		8		bar	
N	INICIAL INITIAL	FINAL END	43,5	58	65,3	72,5	79,8	87	101,5	116										
6*	18,8	12,7						8,2	2,1	10,7	4,6	13,3	7,2	15,8	9,7	20,9	14,8	26	19,9	Nm
	166,4	112,4						72,2	18,2	94,7	40,7	117,7	63,7	139,8	85,8	185,0	131,0	230,1	176,1	Lb.in
5	15,8	10,7			7,6	2,5	10,2	5,1	12,7	7,6	15,3	10,2	17,8	12,7	22,9	17,8	28	22,9	Nm	
	139,8	94,7			67,3	22,1	89,9	44,8	112,4	67,3	135,4	90,3	157,5	112,4	202,7	157,5	247,8	202,7	Lb.in	
4	12,6	8,7			9,6	5,7	12,2	8,3	14,7	10,8	17,3	13,4	19,8	15,9	24,9	21	30	26,1	Nm	
	111,5	77			85,0	50,4	107,6	73,1	130,1	95,6	153,1	118,6	175,2	140,7	220,4	185,9	265,5	231,0	Lb.in	
3	9,7	6,6	6,7	3,6	11,7	8,6	14,3	11,2	16,8	13,7	19,4	16,3	21,9	18,8	27	23,9	32,1	29	Nm	
	85,8	58,4	59,3	31,9	103,5	76,1	126,2	98,8	148,7	121,2	171,7	144,3	193,8	166,4	239	211,5	284,1	256,7	Lb.in	
2	6,6	4,1	9,2	6,7	14,2	11,7	16,8	14,3	19,3	16,8	21,9	19,4	24,4	21,9	29,5	27	34,6	32,1	Nm	
	58,4	36,3	81,4	59,3	125,7	103,5	148,3	126,2	170,8	148,7	193,8	171,7	215,9	193,8	261,1	239	306,2	284,1	Lb.in	

N: Número de muelles por banda y posición
Number of springs per side and position

* Número de muelles estándar
* Standard number of springs