

Series ZR

Design and function

The toothed belt cylinder consists of an extruded cylinder tube with two chambers. They are connected to each other over the entire length of the cylinder. The pressure chamber is sealed by a PU seal strip. Between the two piston seals a pressure-free space is created. In this space the seal band is lifted to the inside and is passed through the piston. Simultaneously, a driver (piston bracket) grasps through the slot into the outer chamber. Since the outer chamber encloses the longitudinal slot, it does not expand under pressure. This results in minimal leakage and better flexural and torsional stiffness.

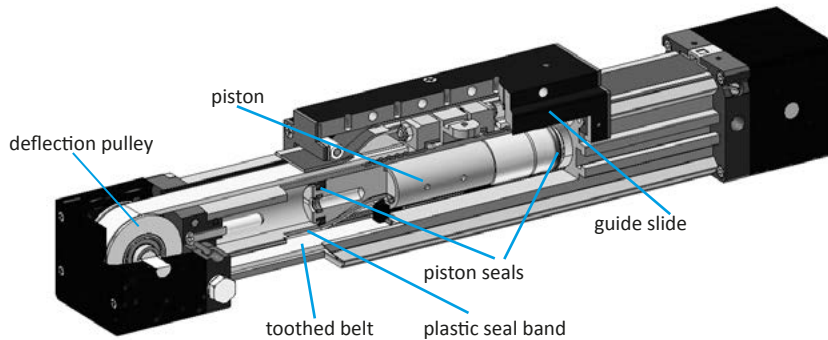

In the outer chamber, the piston bracket grips the toothed belt, which leads to a tension lock at the opposite side via the deflection pulley. Inside the slide, the cover belt is lifted from the slot, and the slide is connected to the tension lock. By this principle, dirt is kept away from the sealing strip enabling use under rough operating conditions. The force is transmitted, free of slip, to a shaft via the toothed belt pulley. As a result, several cylinders can be linked and operated synchronously, enabling torques from the off-center application forces. The cylinder can also be supplied with a brake mounted on the driven shaft without the use of an additional energy transmission chain. A cylinder supplied with a brake and encoder results in an inexpensive positioning system. Since the slide or roller guide is already integrated into the slide, a complete linear drive is available with this cylinder.

With 2 slides

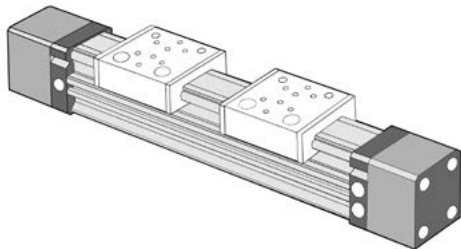

For higher loads.

As a gripping cylinder

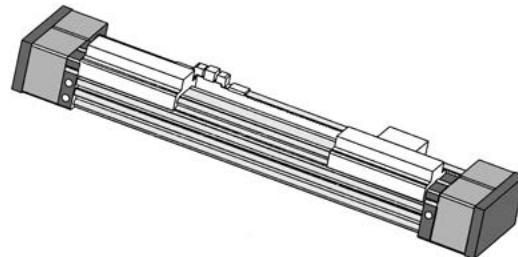

By mounting a second toothed belt and using a slide in tangential feed.

Synchronous running

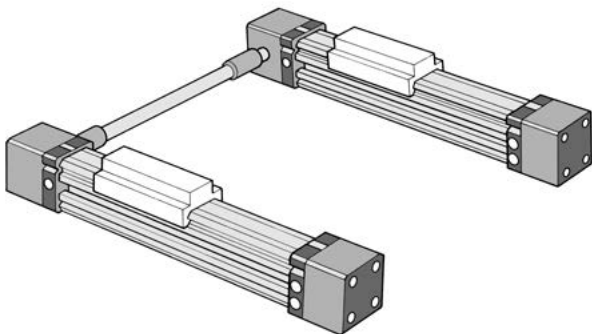

The system is suitable for synchronisation of 2 or more cylinders. (see options)

With brake / with encoder mount

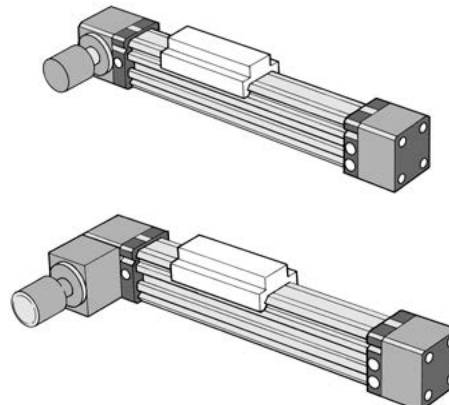

Since the running performance is stick slip free, an encoder mount is possible. A holding brake keeps the position. (see options)

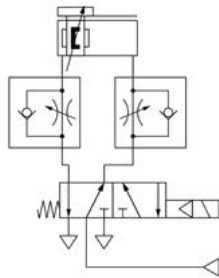
Circuit examples
Control 1

Simple system for controlling the slide from end to end. A flow control valve can be used to adjust the cylinder speed.

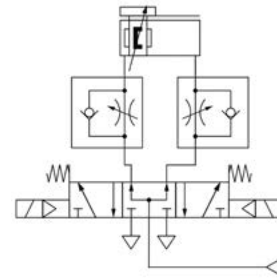
Control 2

System to stop the cylinder on intermediate position with higher tolerances.

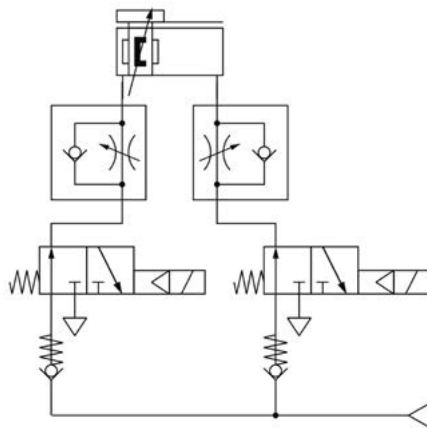
Control 3

This control circuit improves the positioning accuracy. The use of check valves reduces the stopping distance and also increases the load stiffness.

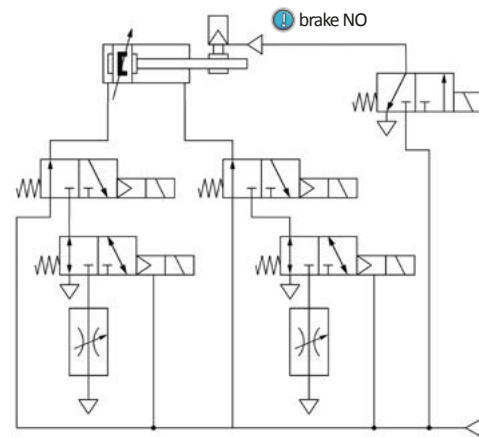
Control 4

This circuit example permits the selection of different speeds (rapid or inching) for either forward or reverse motion. The brake is activated by a 3/2 solenoid valve.

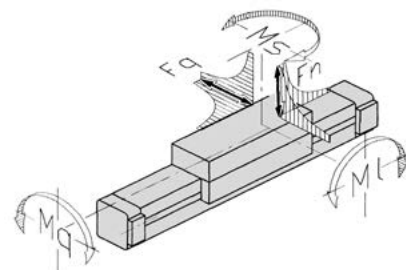
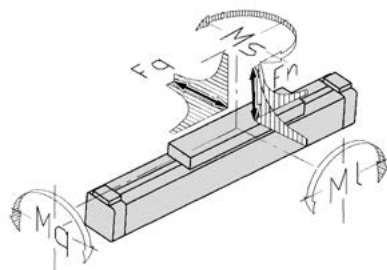
Loads, forces and torques

Cylinder	Operating force *	Braking force**	F_n	F_q	M_I	M_q	M_s
ZR-25	250 N	380 N	400 N	400 N	40 Nm	20 Nm	30 Nm
ZR-25S	250 N	380 N	400 N	400 N	80 Nm	40 Nm	60 Nm
ZR-40	640 N	750 N	800 N	800 N	75 Nm	30 Nm	50 Nm
ZR-40S	640 N	750 N	800 N	800 N	150 Nm	60 Nm	100 Nm
ZR-40L	640 N	750 N	1200 N	1200 N	95 Nm	45 Nm	95 Nm

v in m/s	0.2	0.3	0.4	0.5	0.75	1
Factor***	1	0.75	0.5	0.4	0.27	0.2

* at 6 bar

** only at versions with brake, braking force at 6 bar, static

*** Force and torque data are based on the speed of the slide guideways of ≤ 0.2 m/s, in case of roller guides of ≤ 2 m/s.

If speed exceeds 0.2 m/s, the permissible values of the slide guideways must be multiplied by the factors from the table. For roller or ball guide types is no factor required.

Series ZR

Technical details

Operating pressure	1 ... 8 bar
Temperature range	-15°C ... +70°C
max. Stroke	4500 mm (4300 mm for ZR-**S)
Medium	Filtered, oil-free and dried compressed air according to ISO 8573-1:2010, Class 7:2:4, instrument air, free of aggressive additives. Alternatively the pressure dew point must be at least 10°C below lowest occurring ambient temperature. If speeds exceed 1 m/s lubricated air is recommended.
Materials	Cylinder tube: Al (anodized) End caps: Al (anodized) Seals: PA, NBR, PDF



Double acting rodless toothed belt cylinder with adjustable cushions. The toothed belt is driven by the piston in a closed profile tube. The piston actuates a slide with an adjustable slide guideway.
Note: Slide guide and piston are working in opposite direction.

Versions

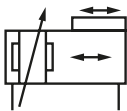

ZR-***
double acting, adjustable cushioning,
with magnetic piston

Order code

ZR- *-*-*-*-*-*-*-***

<p>Series</p> <p>Piston Ø 25 25 mm 40 40 mm</p> <p>Guide blank slide guide S heavy-duty slide guide L roller bearing guide (only for Ø 40)</p> <p>Stroke (mm) XXXX max. 4500 mm (max. 4300 mm for ZR-**S)</p>	<p>Options (details see page 10-25)</p> <p>A brake B brake with extended shaft at opposite side C brake with extended shaft end-to-end (both sides) D brake with extended shaft (brake side) F extended shaft for synchronisation G extended shaft for encoder mounting H extended shaft for encoder mounting and synchronisation J extended shaft end-to-end (both sides) for synchronisation</p> <p>Air connection options (details see page 10-27)</p> <p>1 double air connection at 1 2 double air connection at 2 3 double air connection at 3 4 double air connection at 4</p>
---	--



Technical data

Model-no.:	ZR-25	ZR-40	ZR-25S	ZR-40S	ZR-40L
Piston Ø (mm)	25	40	25	40	40
Connection	G1/8	G1/4	G1/8	G1/4	G1/4
Cushioning length (mm)	25	32	25	32	32
Weight (kg)					
0 mm stroke	2.18	3.19	2.58	3.59	4.84
each 100 mm stroke	0.40	0.50	0.40	0.50	0.70

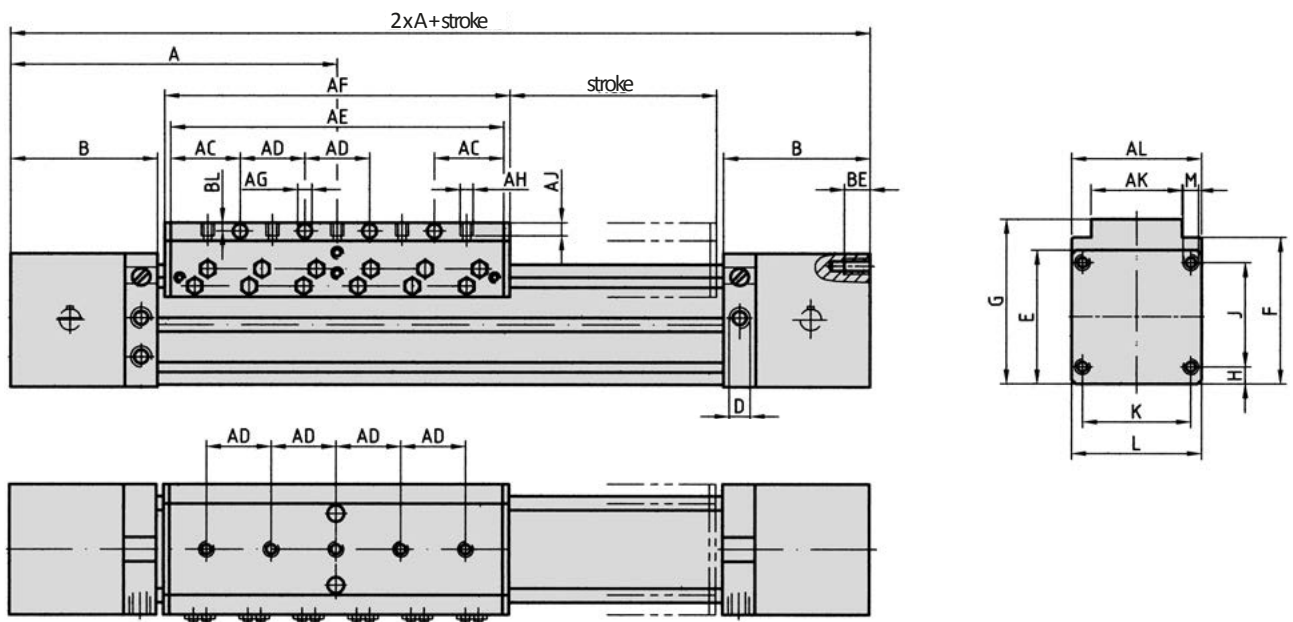
Dimensions series ZR

Cylinder	A	B	D	E	F	G	H	J	K	L	M
ZR-25	150	68	G1/8	62	67.5	76	8	48	50	60	M5
ZR-40	150	75	G1/4	76.8	80.5	97.5	9	54	54	72	M6

Cylinder	AC	AD	AE	AF	AG	AH	AJ	AK	AL	BE	BL
ZR-25	33	30	156	160	5.5	M5	7	42	60	10	4
ZR-40	25	30	140	148	5.5	M5	8.5	40	72	12	6

Series ZR

Dimensions series ZR-S

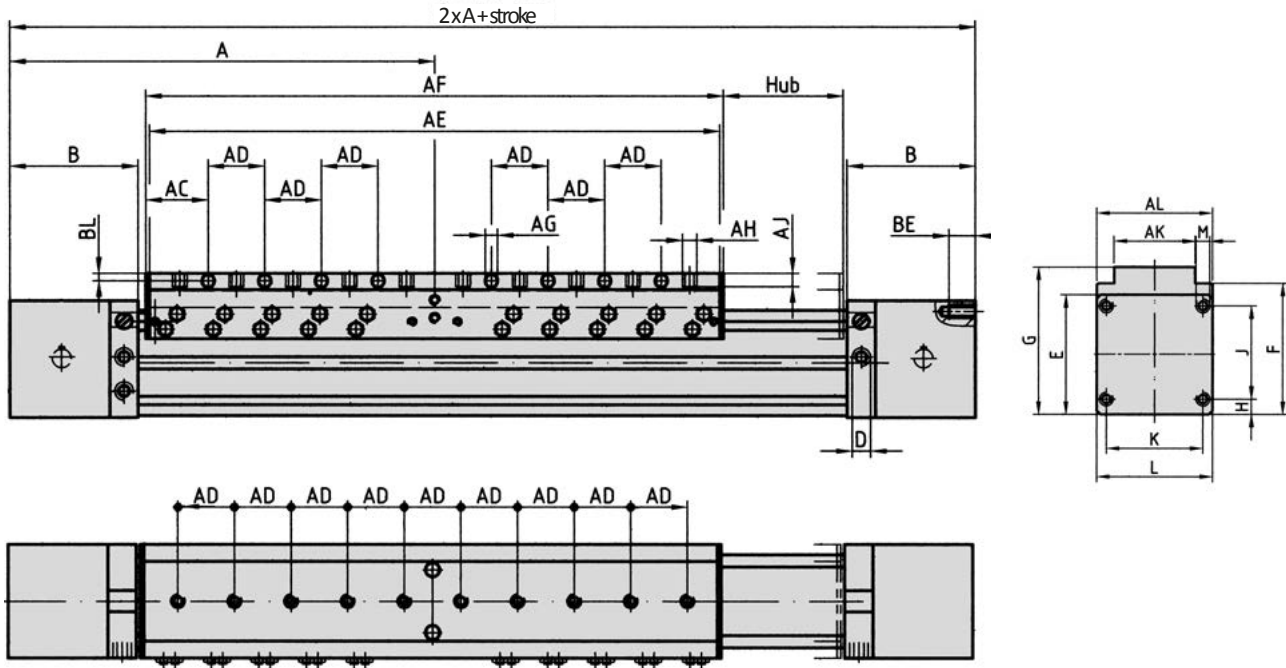

Cylinder	A	B	D	E	F	G	H	J	K	L	M
ZR-25S	225	68	G1/8	62	67.5	76	8	48	50	60	M5
ZR-40S	225	75	G1/4	76.8	80.5	97.5	9	54	54	72	M6

Cylinder	AC	AD	AE	AF	AG	AH	AJ	AK	AL	BE	BL
ZR-25S	35	30	306	310	5.5	M5	7	42	60	10	4
ZR-40S	29	30	290	298	5.5	M5	8.5	40	72	12	6



Dimensions series ZR-L

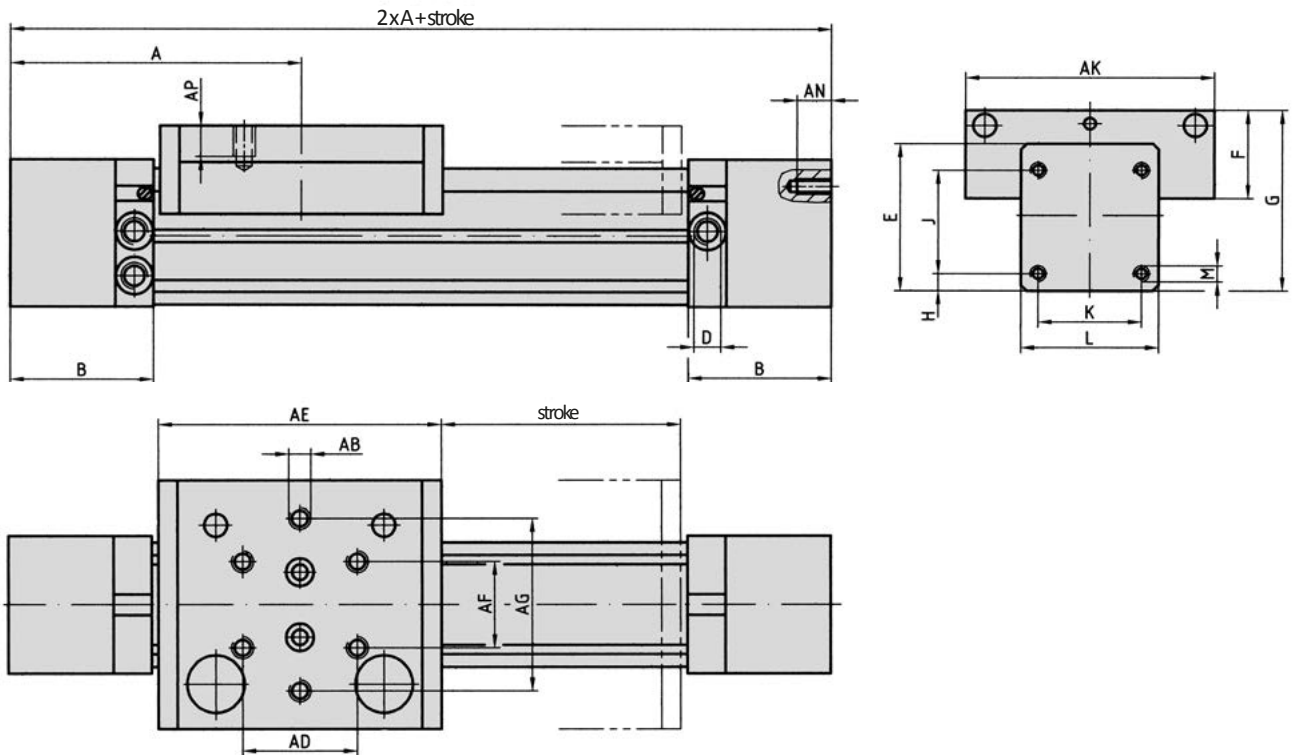

Cylinder	A	B	D	E	F	G	H	J	K	L
ZR-40L	150	75	G1/4	76.8	46.1	94.4	9	54	54	72

Cylinder	M	AB	AD	AE	AF	AG	AK	AN	AP
ZR-40L	M6	M8	60	148	45	90	130	12	15

Series ZR

Mounting parts

ZK-xx2 Head mount

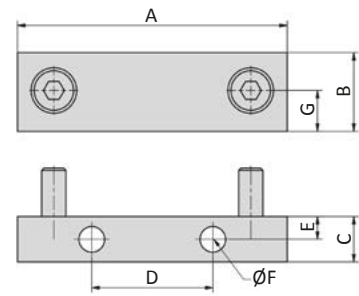

Model-no.:	A	B	C	D	E	Ø F	G
ZK-252	60	20	20	30	10	9	11
ZK-402	71	20	20	30	10	9	11

Screws to mount the head mount to the cylinder are included.

ZK-xx3 Head mount, tall (for use in combination with center mount)

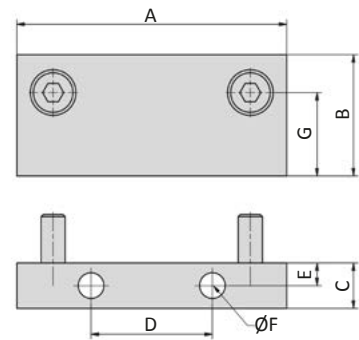

Model-no.:	A	B	C	D	E	Ø F	G
ZK-253	60	30	20	30	10	9	17
ZK-403	71	30	20	30	10	9	18

Screws to mount the head mount to the cylinder are included.

ZK-xx1 Center mount

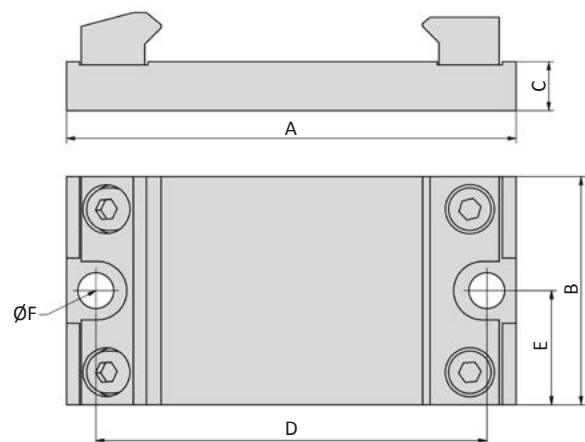

Model-no.:	A	B	C	D	E	Ø F
ZK-251	90	60	10	75	37.5	9
ZK-401	100	60	10	84	42	9

ZA-3x Adapter for encoder mounting

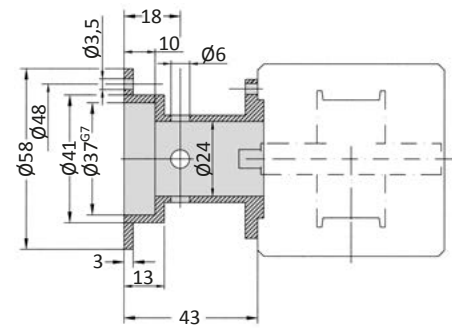

Model-no.:	Mounting
ZA-36	mounted on brake
ZA-37	mounted on head

The adapters can be mounted on all cylinders of series ZR and will fit to all encoders with a 36 mm centering collar.

BR-xx Brake

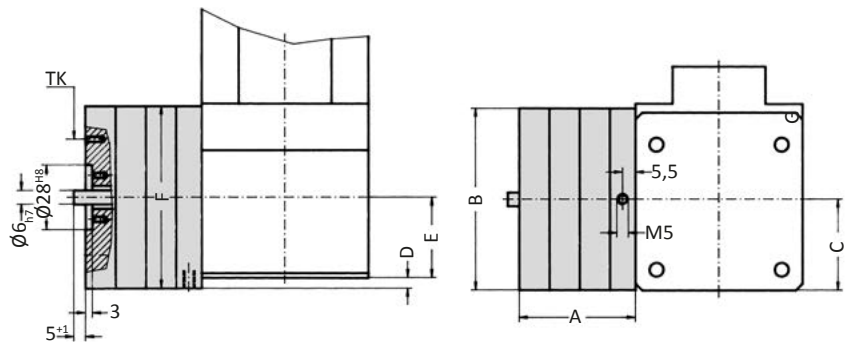

Model-no.:	A	B	C	D	E	F	TK
BR-25	43	61	31.2	2	27.5	51	45 (3 x M3 x 6 deep drawn offset)
BR-40	50	78.5	39.4	4.5	34.7	78.5	50 (3 x M3 x 7 deep drawn offset)

BR-25 Braking force static

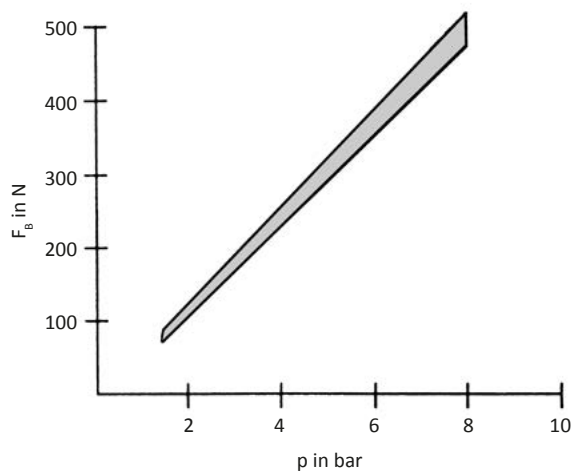

BR-40 Braking force static

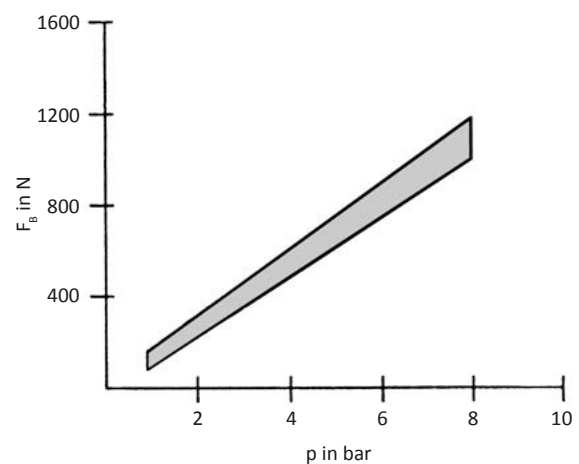

The brake is designed to hold the position. Do not use to stop the cylinder.



Series ZR

Accessories

Extended shaft

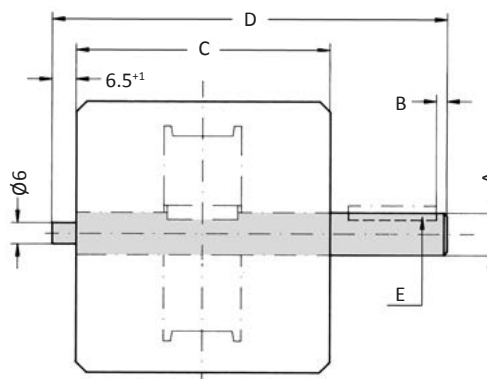

Piston Ø	A	B	C	D	E (key)	slide travel (mm) per one rotation
25	10 _{h7}	2	60	93	3 x 3 x 20 DIN 6885	135
40	12 _{h7}	3	72	112	4 x 4 x 25 DIN 6885	185

ZR-4006 Magnet

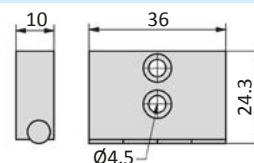

For use with our proximity sensor ZS-100.1. The magnet is mounted at the slide. Mounting screws are included. The model ZE-40L has the magnet already included.

ZR-4007 Mounting bracket for proximity sensors

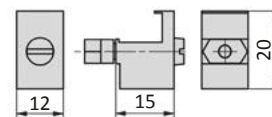

For direct mounting at the cylinder groove.

ZS-100.1 Proximity sensor

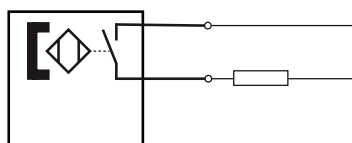

Model-no.:	ZS-100.1
Design	2-pole Reed sensor
Contact function	NO
Rated operational voltage	3 ... 250 V AC / DC
Rated operational current I _e	1 A
Breaking capacity	50 W bzw. 50 VA
Cable	2 x 0.25 mm ² , 3 m length
Temperature range	-30 ... +80°C
Protection	IP 67
Switching status indication	LED red
Switching time	< 2 ms
Response time	< 0.1 ms

Option A1

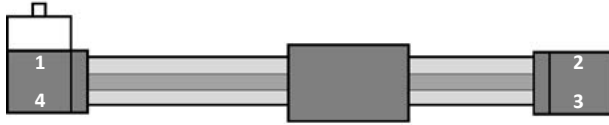

Brake with encoder connection mounted at 1

Option A3

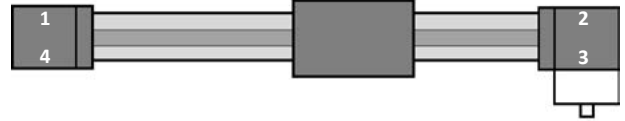

Brake with encoder connection mounted at 3

Option B1

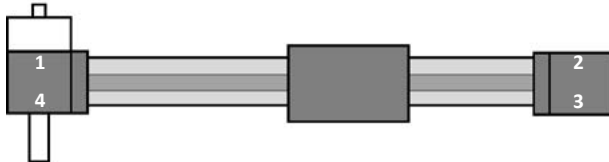

Brake at 1 with extended shaft for synchronisation at 4

Option B3

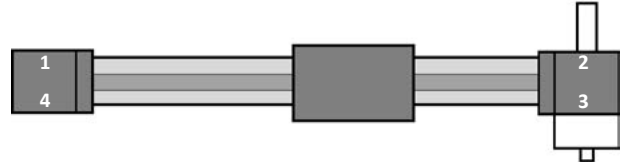

Brake at 3 with extended shaft for synchronisation at 2

Option C1

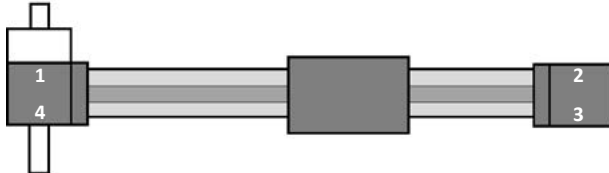

Brake at 1 with shaft for synchronisation at 1 and 4

Option C3

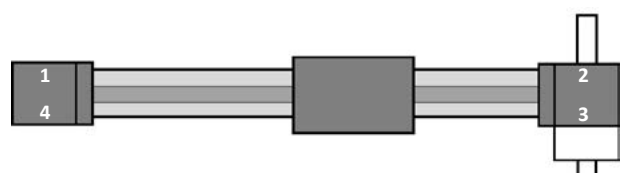

Brake at 3 with shaft for synchronisation at 2 and 3

Option D1

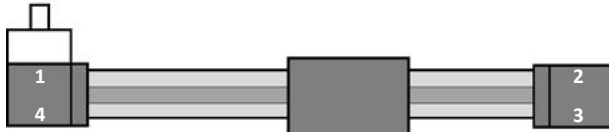

Brake at 1 with extended shaft for synchronisation at 1

Option D3

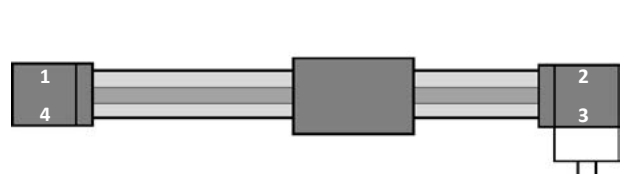

Brake at 3 with extended shaft for synchronisation at 3

Option F1



Shaft for synchronisation at 1

Option F2

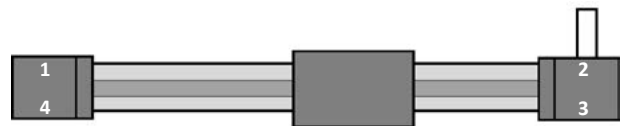

Shaft for synchronisation at 2

Option F4

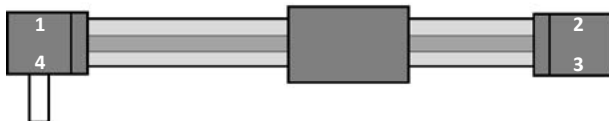

Shaft for synchronisation at 4

Option F3

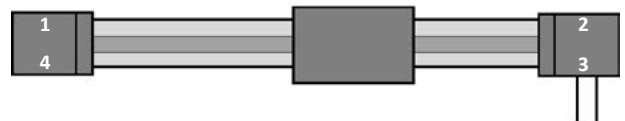

Shaft for synchronisation at 3

Option G1



Shaft for encoder connection at 1

Option G2



Shaft for encoder connection at 2

Series ZR Accessories

Option G4

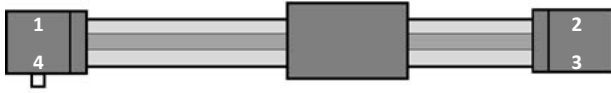

Shaft for encoder connection at 4

Option G3

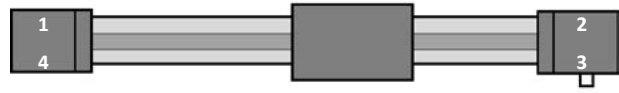

Shaft for encoder connection at 3

Option H1

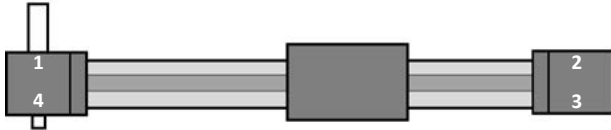

Shaft for encoder connection at 4 and synchronisation at 1

Option H2

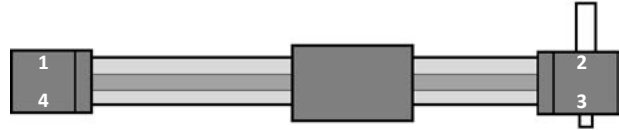

Shaft for encoder connection at 3 and synchronisation at 2

Option H4

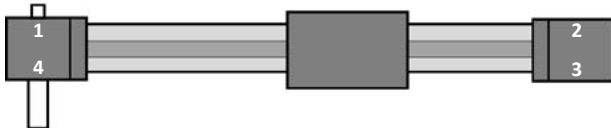

Shaft for encoder connection at 1 and synchronisation at 4

Option H3

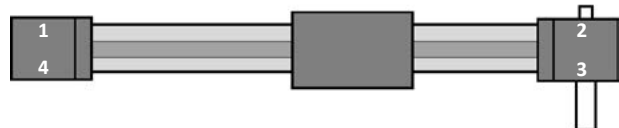

Shaft for encoder connection at 2 and synchronisation at 3

Option J1

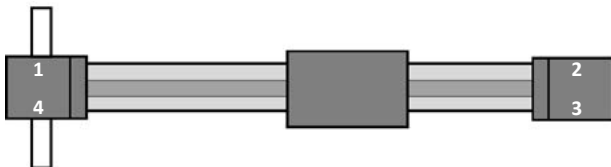

Shaft for synchronisation at 1 and 4

Option J3

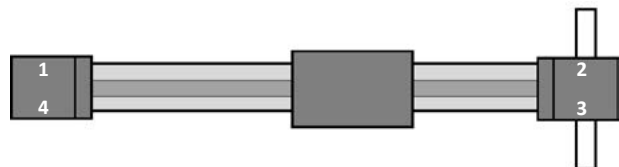

Shaft for synchronisation at 2 and 3



Option 1

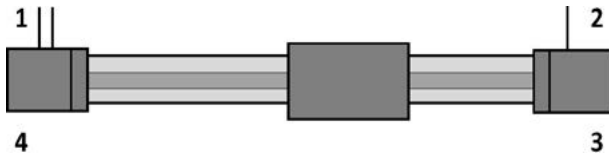

Option 2

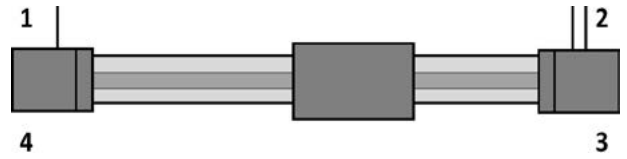

Option 4

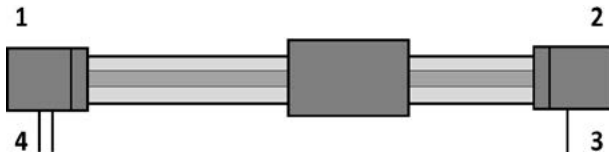

Option 3

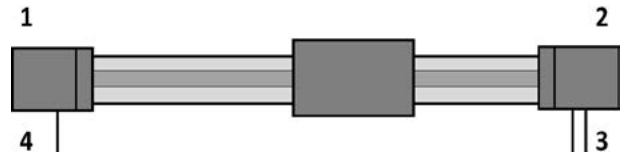

The cylinder is supplied with three air connections. Two connections are necessary for operation, while the third is closed by a plug (included in the scope of delivery). The desired position of the double connection has to be specified in the order code after the stroke length by choosing the adequate number.