

DESPIECE

DISASSEMBLY



Nº	Descripción Description	Cant. Quant.	Material Material
1	TORNILLO AVELLANADO TAPA CAP COUNTERSUNK SCREW	8	ACERO INOXIDABLE AISI-304 AISI-304 STAINLESS STEEL
2	TAPA CAP	2	POLIAMIDA + FV POLYAMIDE + FG
3	JUNTA TÓRICA TAPA CAP-O-RING	2	N.B.R. N.B.R.
4	ÉMBOLO PISTON	2	POLIARILAMIDA POLYARILAMIDE
5	CILINDRO CYLINDER	1	POLIAMIDA + FV POLYAMIDE + FG
6	ARANDELA WASHER	1	POLIACETAL POLYACETAL
7	ANILLO DE SEGURIDAD SPRING CLIP	1	ACERO INOXIDABLE STAINLESS STEEL
8	INDICADOR VISUAL POSITION INDICATOR	1	POLIACETAL POLYACETAL
9	ANILLO GUIA GUIDE RING	2	POLIACETAL + Mb POLYACETAL + Mb
10	JUNTA TÓRICA ÉMBOLO PISTON O-RING	2	N.B.R. N.B.R.
11	JUNTA TÓRICA O-RING	2	N.B.R. N.B.R.
12	JUNTA TÓRICA O-RING	1	N.B.R. N.B.R.
13	MUELLES PRECARGADOS PRELOADED SPRINGS	12	DIN-17223-C (6) (4) DIN-17223-C (6) (4)
14	EJE SHAFT	1	POLIAMIDA + INSERTO INOX. POLYAMIDE + S.S INSERT
15	DADO DE CONEXIÓN DRIVE ADAPTER	1	ACERO INOXIDABLE STAINLESS STEEL
16	INSERTOS ROSCADOS SHAFT	10	ACERO INOXIDABLE STAINLESS STEEL

ACTUADOR NEUMÁTICO DE POLIAMIDA
POLYAMIDE PNEUMATIC ACTUATOR



PPW: Doble Efecto / Double Acting
PPWS: Simple Efecto / Spring Return

- (4) CANTIDAD VARIABLE, CONSULTAR TABLAS PARES SIMPLE EFECTO.
VARIABLE QUANTITY, PLEASE SEE THE SPRING RETURN TORQUE CHART.
(6) PASIVADO DE CROMO TRIVALENTE.
TRIVALENT CHROMINIUM PASSIVATION.

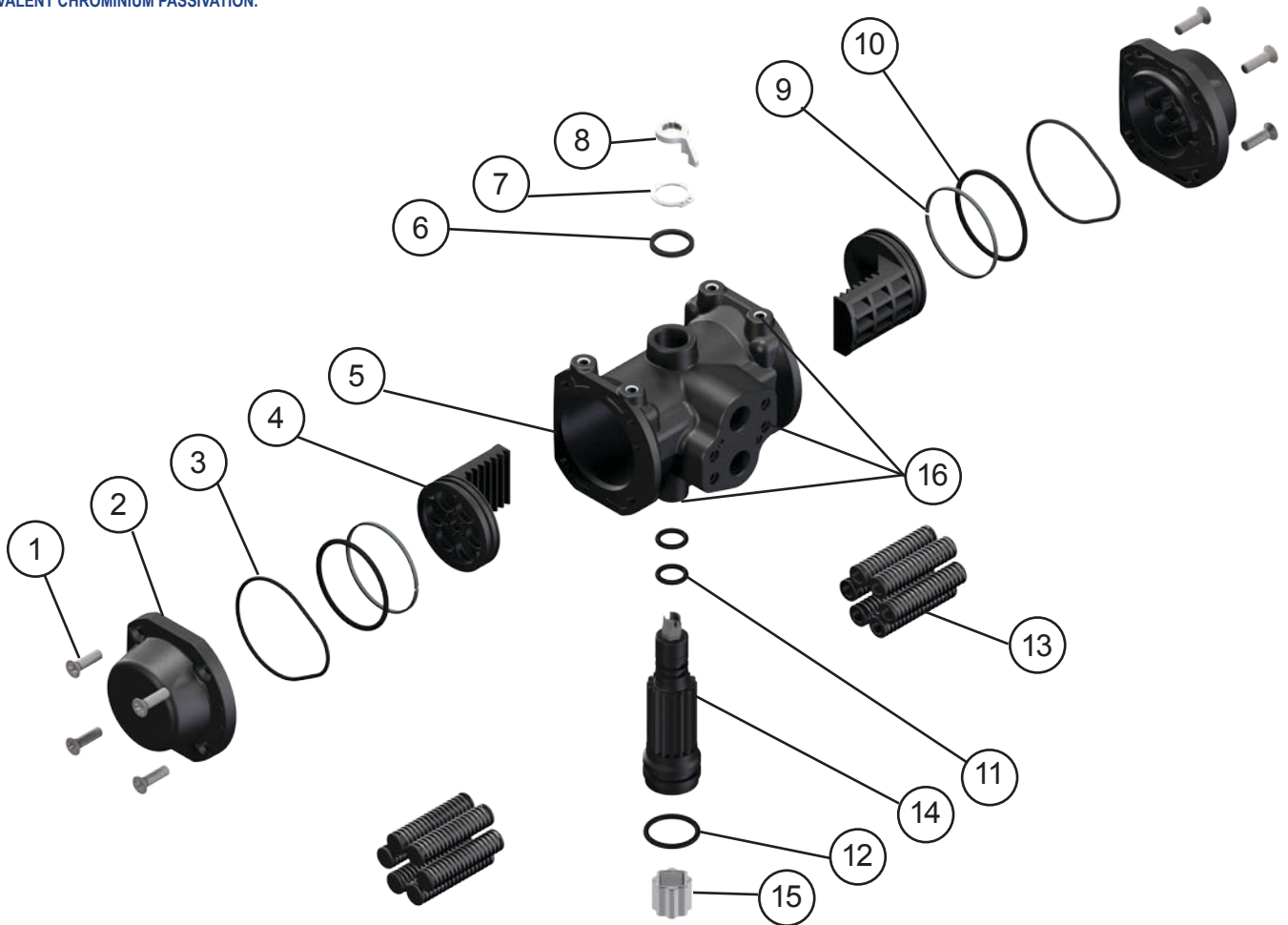

* PPW: SIL3
PPWS: SIL2 / SIL3 (SC)

MODELOS MODELS	TIEMPO DE MANIOBRA EN SEG. CYCLE TIME IN SECS.		PESOS WEIGHTS		CAPACIDAD EN LITROS CAPACITY IN LITRES	
	PARA ABRIR TO OPEN	PARA CERRAR TO CLOSE	Kg.	Lb.	PARA ABRIR TO OPEN	PARA CERRAR TO CLOSE
PPW	0,1	0,1	0,47	1,04	0,075	0,05
PPWS	0,15	0,15	0,55	1,21	0,075	

Tiempo de maniobra sin par resistente a 6 bar.
Cycle time w/o resistant torque at 6 bar.

Dimensiones en mm.
Dimensions in mm.

Para calcular el consumo, multiplicar las cifras del cuadro por la presión real de trabajo.

To calculate the consumption, multiply the above figures by the real working pressure.

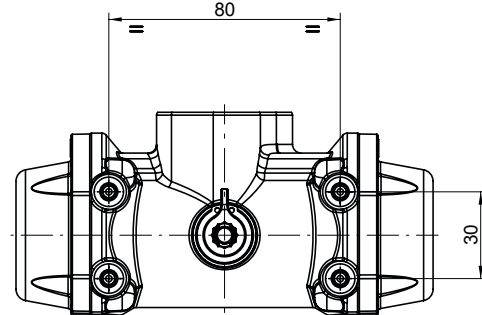
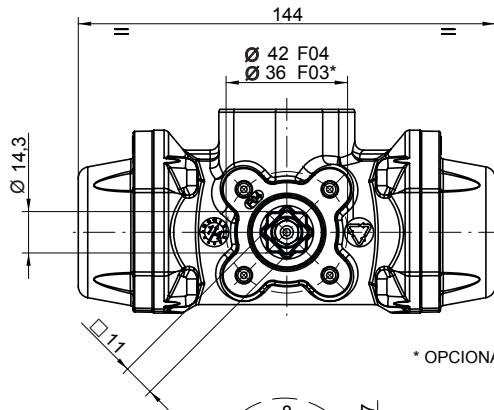

* OPCIONAL / OPTIONAL

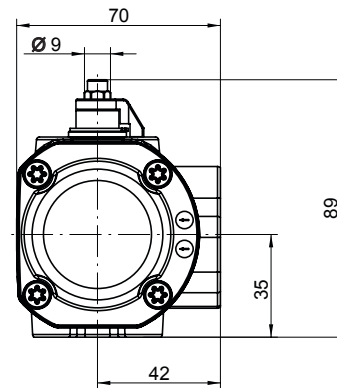
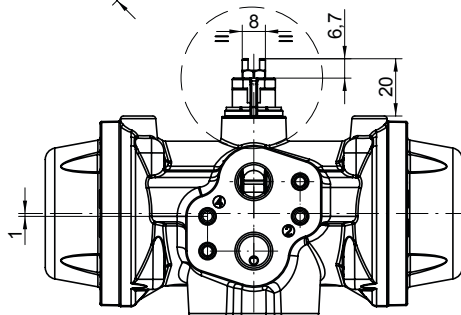

PAIRES DOBLE EFECTO DOUBLE ACTING TORQUES

PPW	PRESION AIRE AIR PRESSURE							
bar	3	4	4,5	5	5,5	6	7	8
p.s.i	43,5	58	65,3	72,5	79,8	87	101,5	116
Nm	7,9	11,3	12,7	14,1	15,5	17	19,8	22,9
Lb.in	69,3	100	112,4	124,8	137,2	150,5	175,2	202,7

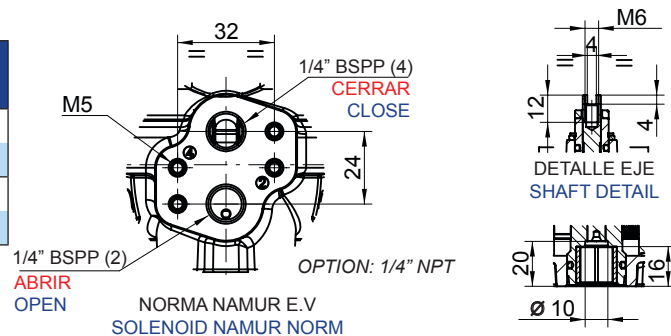

PAIRES SIMPLE EFECTO SPRING RETURN TORQUES

PPWS	PAR MUELLES SPRING TORQUES		PAR A LA PRESIÓN INDICADA AIR TORQUE AT INDICATED PRESSURE																	
			3		4		4,5		5		5,5		6		7		8		bar	
N	INICIAL INITIAL	FINAL END	43,5	58	65,3	72,5	79,8	87	101,5	116										
6*	10	6,7					6	2,7	7,4	4,1	8,8	5,5	10,3	7	13,1	9,8	16,2	12,9		Nm
	88,5	59,3					53,1	23,9	65,5	36,3	77,9	48,7	91,2	62	115,9	86,7	143,4	114,2		Lb.in
5	8,5	5,8			5,5	2,8	6,9	4,2	8,3	5,6	9,7	7	11,2	8,5	14	11,3	17,1	14,4		Nm
	75,2	51,3			48,7	24,8	61,1	37,2	73,5	49,6	85,9	62	99,1	75,2	123,9	100	151,3	127,5		Lb.in
4	7	4,6	3,3	0,9	6,7	4,3	8,1	5,7	9,5	7,1	10,9	8,5	12,4	10	15,2	12,8	18,3	15,9		Nm
	62	40,7	29,2	8	59,3	38,1	71,7	50,4	84,1	62,8	96,5	75,2	109,7	88,5	134,5	113,3	162	140,7		Lb.in
3	5,5	3,6	4,3	2,4	7,7	5,8	9,1	7,2	10,5	8,6	11,9	10	13,4	11,5	16,2	14,3				Nm
	48,7	31,9	38,1	21,2	68,2	51,3	80,5	63,7	92,9	76,1	105,3	88,5	118,6	101,8	143,4	126,6				Lb.in
2	4	2,4	5,5	3,9	8,9	7,3	10,3	8,7	11,7	10,1	13,1	11,5	14,6	13						Nm
	35,4	21,2	48,7	34,5	78,8	64,6	91,2	77	103,6	89,4	115,9	101,8	129,2	115,1						Lb.in

N: Número de muelles por banda
Number of springs per side

* Número de muelles estándar
* Standard number of springs