

DESPIECE

DISASSEMBLY



ACTUADOR NEUMÁTICO DE ACERO INOXIDABLE CF8M
CF8M STAINLESS STEEL PNEUMATIC ACTUATOR



PI30: Doble Efecto / Double Acting
PI30S: Simple Efecto / Spring Return

Nº	Descripción Description	Cant. Quant.	Material Material
1	TORNILLO ALLEN TAPA CAP ALLEN SCREW	12	ACERO INOX. AISI-316 AISI-316 STAINLESS STEEL
2	TAP CAP	2	ACERO INOXIDABLE CF8M CF8M STAINLESS STEEL
3	JUNTA TÓRICA TAPA CAP-O-RING	2	N.B.R. N.B.R.
4	ÉMBOLO PISTON	2	ALEACIÓN ALUMINIO (2) ALUMINIUM ALLOY (2)
5	CILINDRO CYLINDER	1	ACERO INOXIDABLE CF8M CF8M STAINLESS STEEL
6	ARANDELA WASHER	1	POLIAMIDA 6 POLYAMIDE 6
7	ANILLO DE SEGURIDAD SPRING CLIP	1	ACERO INOXIDABLE STAINLESS STEEL
8	INDICADOR VISUAL POSITION INDICATOR	1	POLIAMIDA POLYAMIDE
9	GUIA ÉMBOLO PISTON GUIDE	4	POLIACETAL POLYACETAL
10	ANILLO GUIA GUIDE RING	2	POLIACETAL POLYACETAL
11	JUNTA TÓRICA ÉMBOLO PISTON O-RING	4	N.B.R. N.B.R.
12	JUNTA TÓRICA EJE SHAFT O-RING	2	N.B.R. N.B.R.
13	JUNTA TÓRICA EJE SHAFT O-RING	2	N.B.R. N.B.R.
14	JUEGO MUELLES PRECARGADOS PRELOADED SPRINGS SET	1	DIN-17223-C (2) (4) DIN-17223-C (2) (4)
16	EJE SHAFT	1	ACERO INOX AISI-316 AISI-316 STAINLESS STEEL
17	PIÑÓN GEAR	1	ALEACIÓN ALUMINIO (5) (2) ALUMINIUM ALLOY (5) (2)
18	JUNTA TÓRICA PLACA PLATE O-RING	2	N.B.R. N.B.R.
19	JUNTA TÓRICA TAPA CAP O-RING	2	N.B.R. N.B.R.
20	PLACA CONEXIÓN NEUMÁTICA PNEUMATIC CONNECTION PLATE	1	ACERO INOXIDABLE CF8M CF8M STAINLESS STEEL
21	TORNILLO ALLEN PLACA PLATE ALLEN SCREW	2	ACERO INOXIDABLE AISI-316 AISI-316 STAINLESS STEEL
22	TORNILLO BOLT	2	ACERO INOXIDABLE AISI-316 AISI-316 STAINLESS STEEL
23	TUERCA NUT	2	ACERO INOXIDABLE AISI-316 AISI-316 STAINLESS STEEL
24	ARANDELA BUSHING	2	ACERO INOXIDABLE AISI-316 AISI-316 STAINLESS STEEL
25	JUNTA TÓRICA O-RING	2	N.B.R. N.B.R.
26	LEVA CAM	1	ACERO INOXIDABLE CF8 CF8 STAINLESS STEEL

- (2) RECUBRIMIENTO POR CATAFORESIS.
COVERED BY CATAPHORESIS.
- (4) CANTIDAD VARIABLE, CONSULTAR TABLAS PARES SIMPLE EFECTO.
VARIABLE QUANTITY, PLEASE SEE THE SPRING RETURN TORQUE CHART.
- (5) BRUÑIDO CON BOLAS.
BALL BURNISHING.

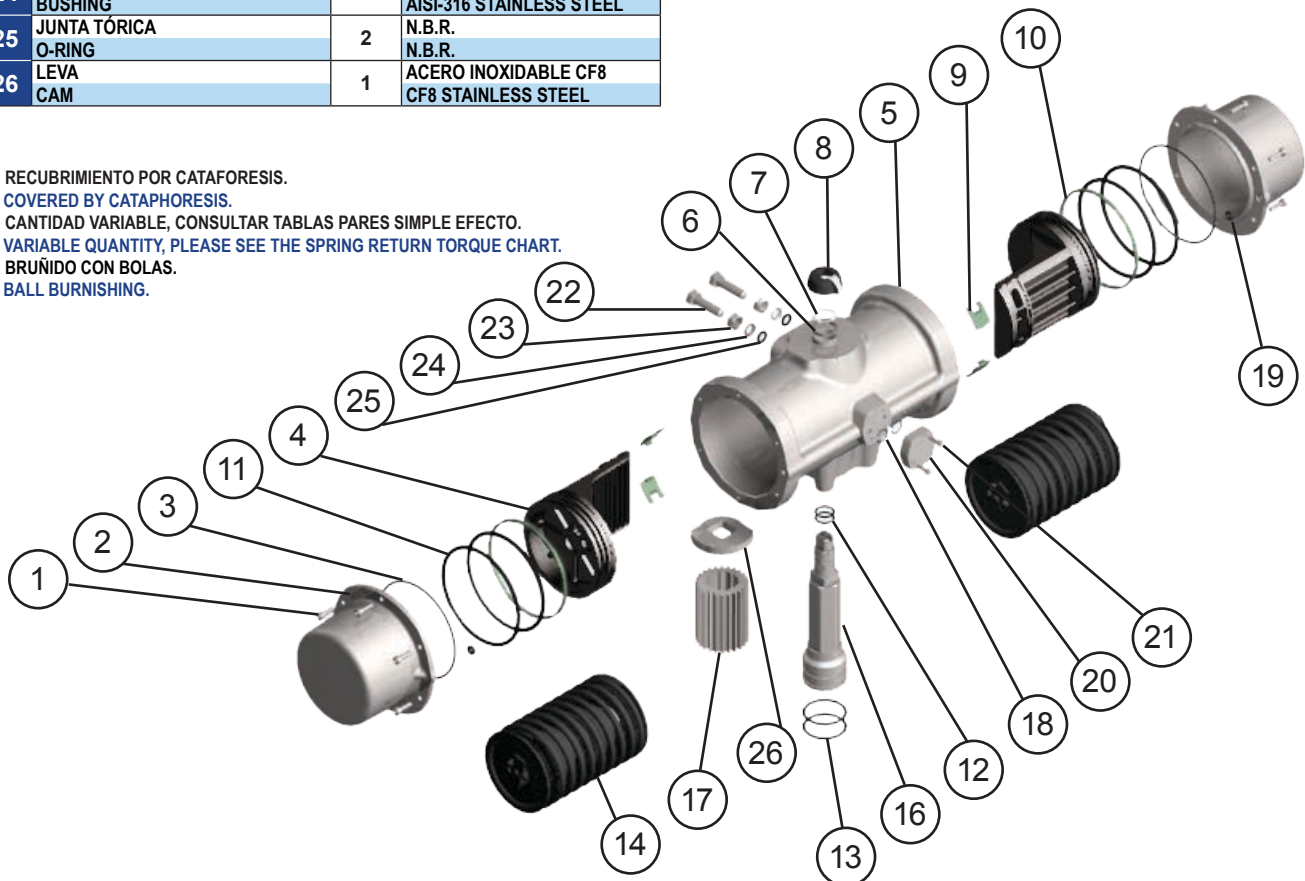

* PI30: SIL2
PI30S: SIL2 / SIL3 (SC)

MODELOS MODELS	TIEMPO DE MANIOBRA EN SEG. CYCLE TIME IN SECS.		PESOS WEIGHTS		CAPACIDAD EN LITROS CAPACITY IN LITRES	
	PARA ABRIR TO OPEN	PARA CERRAR TO CLOSE	Kg.	Lb.	PARA ABRIR TO OPEN	PARA CERRAR TO CLOSE
PI30	0,6	0,6	17,9	39,46	2,05	1,9
PI30S	1,2	1,2	25,4	56,00	2,05	

Tiempo de maniobra sin par resistente a 6 bar.
Cycle time w/o resistant torque at 6 bar.

Dimensiones en mm.
Dimensions in mm.

Para calcular el consumo, multiplicar las cifras del cuadro por la presión real de trabajo.

To calculate the consumption, multiply the above figures by the real working pressure.

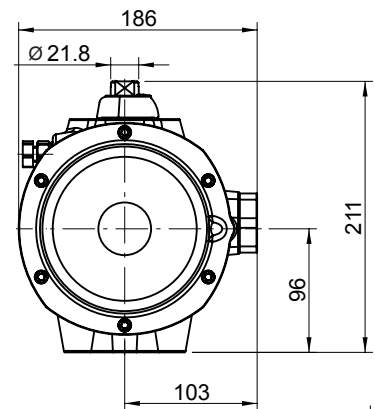
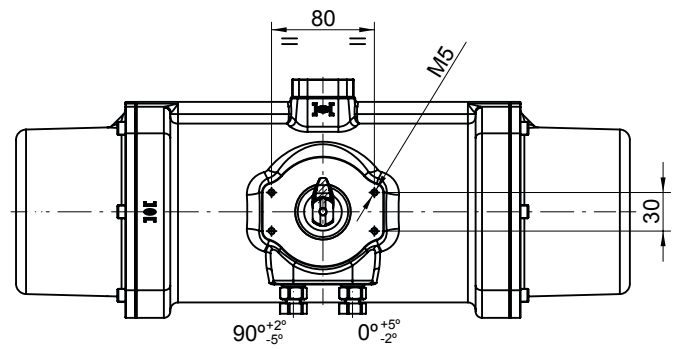
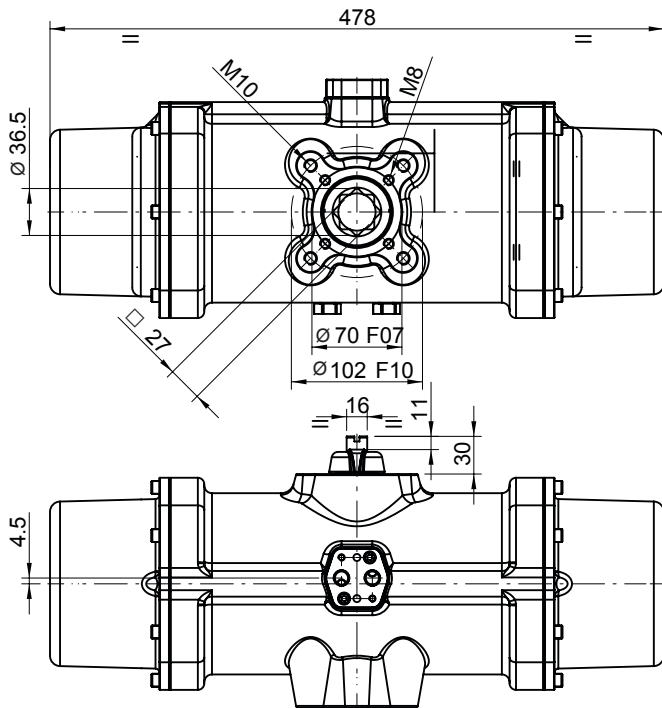

PARES DOBLE EFECTO DOUBLE ACTING TORQUES

PI30	PRESION AIRE AIR PRESSURE							
bar	3	4	4,5	5	5,5	6	7	8
p.s.i	43,5	58	65,3	72,5	79,8	87	101,5	116
Nm	226,5	307,4	347,9	388,3	428,8	469,2	550,1	631
Lb.in	2.004	2.720	3.078	3.436	3.795	4.152	4.868	5.584

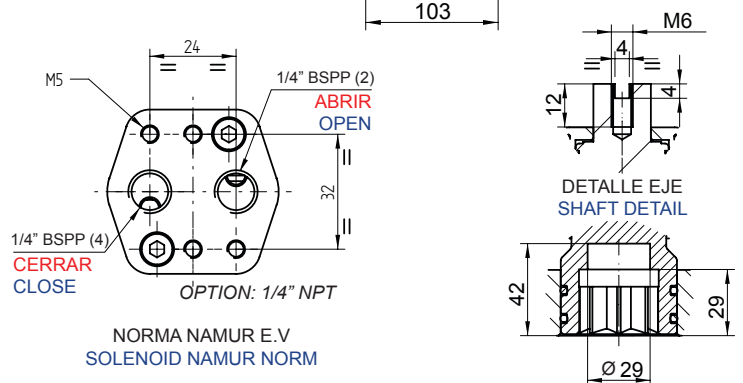

PARES SIMPLE EFECTO SPRING RETURN TORQUES

PI30S	PAR MUELLES		PAR A LA PRESIÓN INDICADA																AIR TORQUE AT INDICATED PRESSURE	
	SPRING TORQUES		3		4		4,5		5		5,5		6		7		8		bar	
	INICIAL INITIAL	FINAL END	43,5	58	65,3	72,5	79,8	87	101,5	116									p.s.i	
N	INICIAL	FINAL	INICIAL	FINAL	INICIAL	FINAL	INICIAL	FINAL	INICIAL	FINAL	INICIAL	FINAL	INICIAL	FINAL	INICIAL	FINAL	INICIAL	FINAL		
	INITIAL	END	INITIAL	END	INITIAL	END	INITIAL	END	INITIAL	END	INITIAL	END	INITIAL	END	INITIAL	END	INITIAL	END		
4*	273,7	179,9			127,5	33,7	168	74,2	208,4	114,6	248,9	155,1	289,3	195,5	370,2	276,4	451,1	357,3	Nm	
	2.422	1.592			1.129	298,3	1.486	656	1.845	1.014	2.203	1.373	2.561	1.730	3.277	2.446	3.992	3.162	Lb.in	
3	203,3	140,8	85,8	23,2	166,6	104,1	207,1	144,6	247,5	185	288	225,5	328,4	265,9	409,3	346,8	490,2	427,7	Nm	
	1.799	1.246	758,9	205,3	1.475	921,1	1.832	1.279	2.191	1.637	2.549	1.996	2.907	2.353	3.623	3.069	4.338	3.785	Lb.in	
2	148,6	93,8	132,7	77,9	213,6	158,8	254,1	199,3	294,5	239,7	335	280,2	375,4	320,6	456,3	401,5			Nm	
	1.315	830,5	1.174	689,7	1.890	1.405	2.248	1.763	2.606	2.121	2.965	2.480	3.322	2.837	4.038	3.553			Lb.in	
1	93,8	54,7	171,8	132,7	252,7	213,6	293,2	254,1	333,6	294,5	374,1	335	414,5	375,4					Nm	
	830,5	484,4	1.520	1.174	2.236	1.890	2.594	2.248	2.952	2.606	3.311	2.965	3.668	3.322					Lb.in	

N: Número de muelles por banda
Number of springs per side

* Número de muelles estándar
* Standard number of springs