

**DESPIECE**

**DISASSEMBLY**



**ACTUADOR NEUMÁTICO DE ACERO INOXIDABLE CF8M**  
**CF8M STAINLESS STEEL PNEUMATIC ACTUATOR**



**PI30:** Doble Efecto / Double Acting  
**PI30S:** Simple Efecto / Spring Return

Nº	Descripción Description	Cant. Quant.	Material Material
1	TORNILLO ALLEN TAPA CAP ALLEN SCREW	12	ACERO INOX. AISI-316 AISI-316 STAINLESS STEEL
2	TAP CAP	2	ACERO INOXIDABLE CF8M CF8M STAINLESS STEEL
3	JUNTA TÓRICA TAPA CAP-O-RING	2	N.B.R. N.B.R.
4	ÉMBOLO PISTON	2	ALEACIÓN ALUMINIO (2) ALUMINIUM ALLOY (2)
5	CILINDRO CYLINDER	1	ACERO INOXIDABLE CF8M CF8M STAINLESS STEEL
6	ARANDELA WASHER	1	ACERO INOX AISI-316 AISI-316 STAINLESS STEEL
7	ANILLO DE SEGURIDAD SPRING CLIP	1	ACERO INOXIDABLE STAINLESS STEEL
8	INDICADOR VISUAL POSITION INDICATOR	1	POLIAMIDA POLYAMIDE
9	GUÍA ÉMBOLO PISTON GUIDE	4	POLIACETAL POLYACETAL
10	ANILLO GUÍA GUIDE RING	2	POLIACETAL POLYACETAL
11	JUNTA TÓRICA ÉMBOLO PISTON O-RING	4	N.B.R. N.B.R.
12	JUNTA TÓRICA EJE SHAFT O-RING	2	N.B.R. N.B.R.
13	JUNTA TÓRICA EJE SHAFT O-RING	2	N.B.R. N.B.R.
14	JUEGO MUELLES PRECARGADOS PRELOADED SPRINGS SET	1	DIN-17223-C (2) (4) DIN-17223-C (2) (4)
16	EJE SHAFT	1	ACERO INOX AISI-316 AISI-316 STAINLESS STEEL
17	PIÑÓN GEAR	1	ALEACIÓN ALUMINIO (5) (2) ALUMINIUM ALLOY (5) (2)
18	JUNTA TÓRICA PLACA PLATE O-RING	2	N.B.R. N.B.R.
19	JUNTA TÓRICA TAPA CAP O-RING	2	N.B.R. N.B.R.
20	PLACA CONEXIÓN NEUMÁTICA PNEUMATIC CONNECTION PLATE	1	ACERO INOXIDABLE CF8M CF8M STAINLESS STEEL
21	TORNILLO ALLEN PLACA PLATE ALLEN SCREW	2	ACERO INOXIDABLE AISI-316 AISI-316 STAINLESS STEEL
22	TORNILLO BOLT	2	ACERO INOXIDABLE AISI-316 AISI-316 STAINLESS STEEL
23	TUERCA NUT	2	ACERO INOXIDABLE AISI-316 AISI-316 STAINLESS STEEL
24	ARANDELA BUSHING	2	ACERO INOXIDABLE AISI-316 AISI-316 STAINLESS STEEL
25	JUNTA TÓRICA O-RING	2	N.B.R. N.B.R.
26	LEVA CAM	1	ACERO INOXIDABLE CF8 CF8 STAINLESS STEEL

- (2) RECUBRIMIENTO POR CATAFORESIS.  
COVERED BY CATAPHORESIS.
- (4) CANTIDAD VARIABLE, CONSULTAR TABLAS PARES SIMPLE EFECTO.  
VARIABLE QUANTITY, PLEASE SEE THE SPRING RETURN TORQUE CHART.
- (5) BRUÑIDO CON BOLAS.  
BALL BURNISHING.

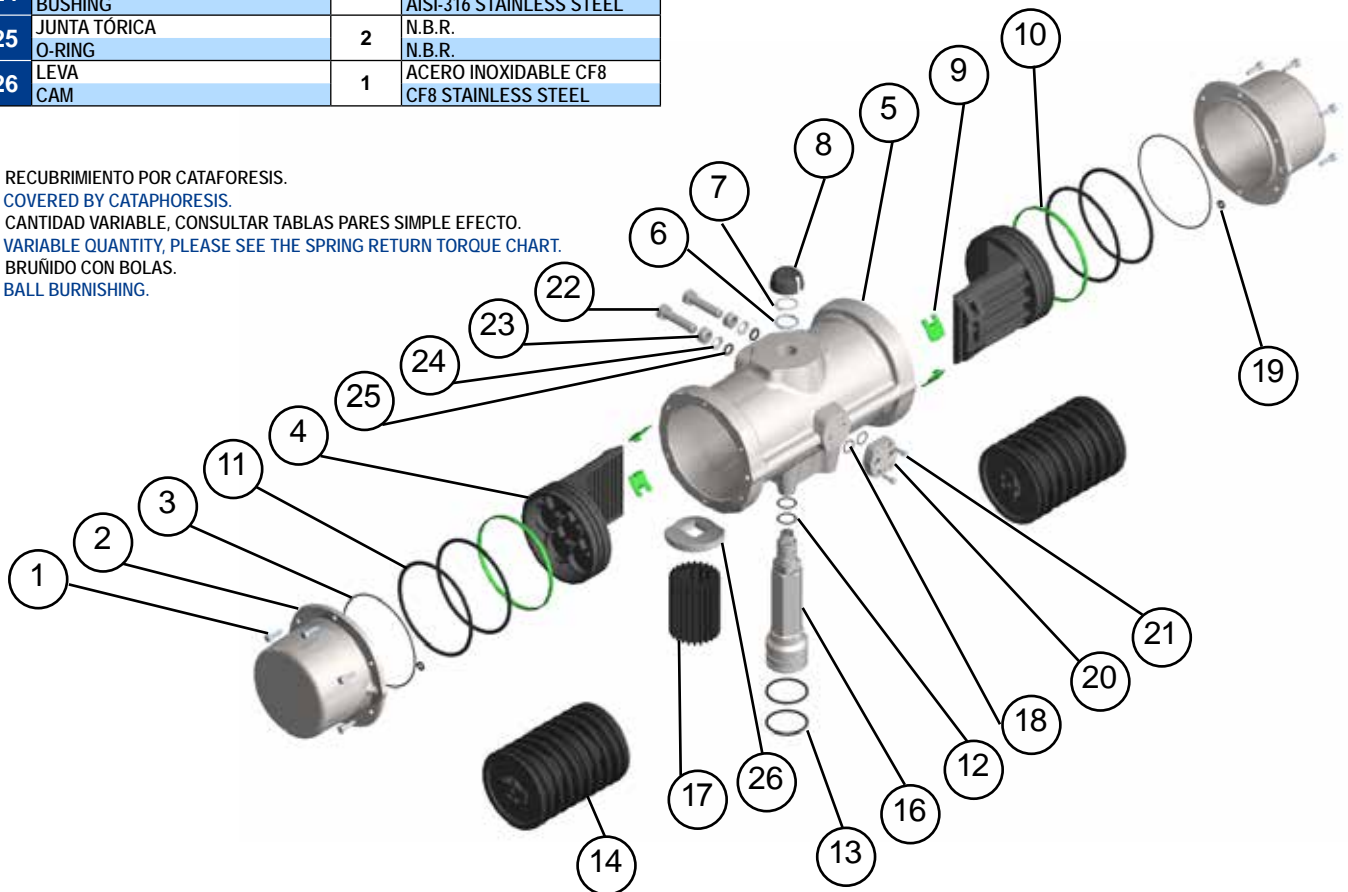

\* PI30: SIL2  
PI30S: SIL2 / SIL3 (SC)

MODELOS MODELS	TIEMPO DE MANIOBRA EN SEG. CYCLE TIME IN SECS.		PESOS WEIGHTS		CAPACIDAD EN LITROS CAPACITY IN LITRES	
	PARA ABRIR TO OPEN	PARA CERRAR TO CLOSE	Kg.	Lb.	PARA ABRIR TO OPEN	PARA CERRAR TO CLOSE
PI30	0,6	0,6	17,9	39,46	2,05	1,9
PI30S	1,2	1,2	25,4	56,00	2,05	

Tiempo de maniobra sin par resistente a 6 bar.  
Cycle time w/o resistant torque at 6 bar.

Dimensiones en mm.  
Dimensions in mm.

Para calcular el consumo, multiplicar las cifras del cuadro por la presión real de trabajo.

To calculate the consumption, multiply the above figures by the real working pressure.

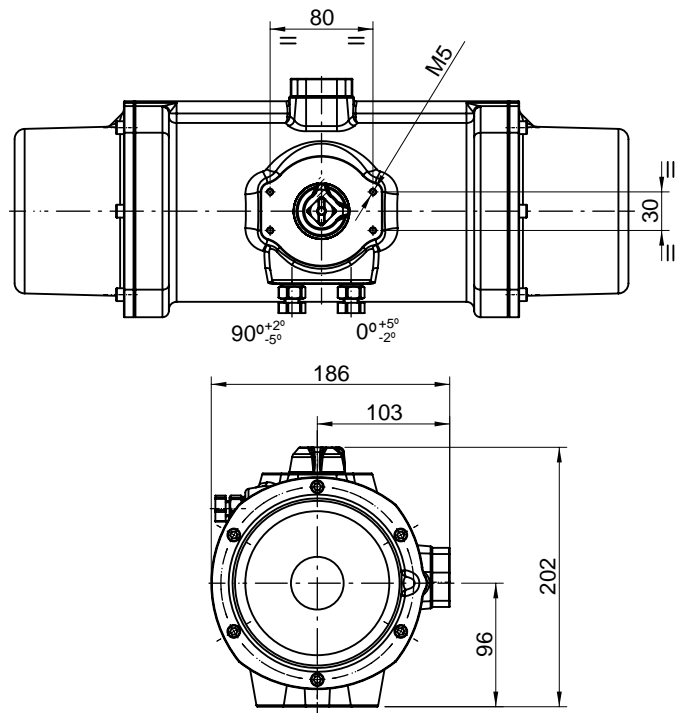
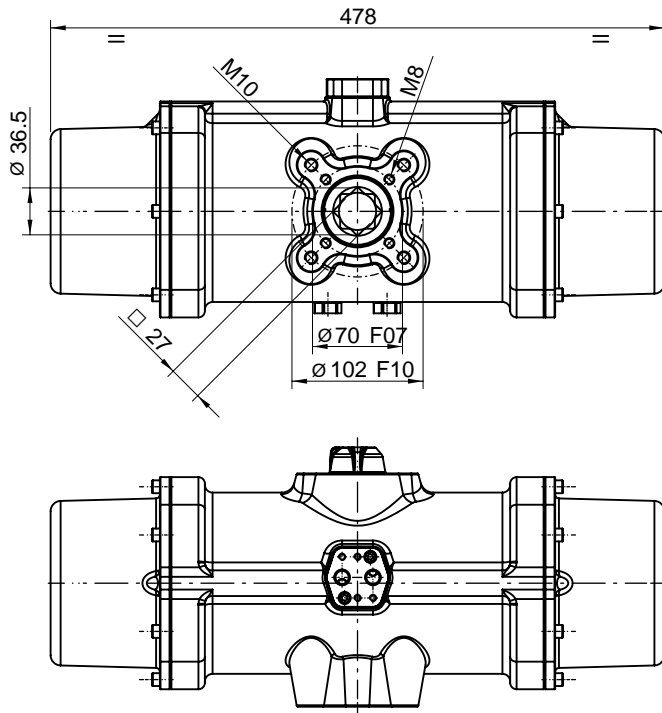

### PARES DOBLE EFECTO DOUBLE ACTING TORQUES

PI30	PRESION AIRE AIR PRESSURE								
	3	4	5	5,5	6	7	8	10	12,5
bar	3	4	5	5,5	6	7	8	10	12,5
p.s.i	43,5	58	72,5	79,8	87	101,5	116	145	181,3
Nm	226,5	307,4	388,3	428,8	469,2	550,1	631	792,5	994,7
Lb.in	2.004	2.720	3.436	3.795	4.152	4.868	5.584	7.015	8.804

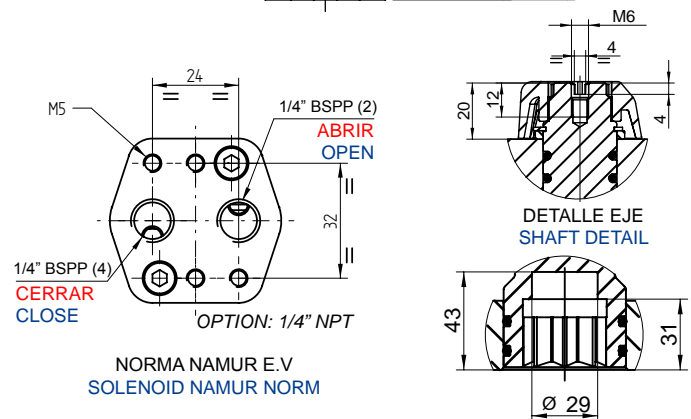

### PARES SIMPLE EFECTO SPRING RETURN TORQUES

PI30S	PAR MUELLES SPRING TORQUES		PAR A LA PRESIÓN INDICADA										AIR TORQUE AT INDICATED PRESSURE									
			3		4		5		5,5		6		7		8		10		12,5		bar	
			43,5		58		72,5		79,8		87		101,5		116		145		181,3			p.s.i
N	INICIAL INITIAL	FINAL END	INICIAL INITIAL	FINAL END	INICIAL INITIAL	FINAL END	INICIAL INITIAL	FINAL END	INICIAL INITIAL	FINAL END	INICIAL INITIAL	FINAL END	INICIAL INITIAL	FINAL END	INICIAL INITIAL	FINAL END	INICIAL INITIAL	FINAL END	INICIAL INITIAL	FINAL END		
4*	273,7	179,9			127,5	33,7	208,4	114,6	248,9	155,1	289,3	195,5	370,2	276,4	451,1	357,3	612,6	518,8	814,8	721	Nm	
	2.422	1.592			1.129	298,3	1.845	1.014	2.203	1.373	2.561	1.730	3.277	2.446	3.992	3.162	5.422	4.592	7.211	6.381	Lb.in	
3	203,3	140,8	85,8	23,2	166,6	104,1	247,5	185	288	225,5	328,4	265,9	409,3	346,8	490,2	427,7	651,7	589,2	853,9	791,4	Nm	
	1.799	1.246	758,9	205,3	1.475	921,1	2.191	1.637	2.549	1.996	2.907	2.353	3.623	3.069	4.338	3.785	5.768	5.215	7.558	7.005	Lb.in	
2	148,6	93,8	132,7	77,9	213,6	158,8	294,5	239,7	335	280,2	375,4	320,6	456,3	401,5	537	482,4	698,7	643,9	900,9	846,1	Nm	
	1.315	830,5	1.174	689,7	1.890	1.405	2.606	2.121	2.965	2.480	3.322	2.837	4.038	3.553	4.754	4.269	6.185	5.700	7.974	7.489	Lb.in	
1	93,8	54,7	171,8	132,7	252,7	213,6	333,6	294,5	374,1	335	414,5	375,4	495,4	456,3	576,3	537,2	737,8	698,7	940	900,9	Nm	
	830,5	484,4	1.520	1.174	2.236	1.890	2.952	2.606	3.311	2.965	3.668	3.322	4.384	4.038	5.100	4.754	6.531	6.185	8.320	7.974	Lb.in	

N: Número de muelles por banda \* Estándar  
N: Number of springs per side \* Standard

Importante: Para presiones de trabajo superiores a 6 bar consultar el manual de operaciones  
Important: For working pressure upper than 6 bar consult the instruction operation manual