

DESPIECE

DISASSEMBLY

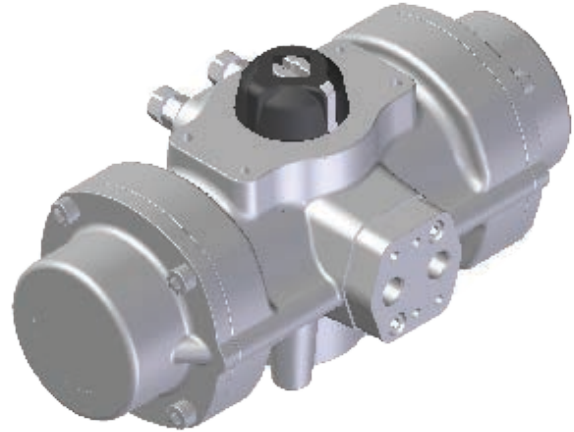

ACTUADOR NEUMÁTICO DE ACERO
INOXIDABLE CF8M
CF8M STAINLESS STEEL
PNEUMATIC ACTUATOR



PI10: Doble Efecto / Double Acting
PI10S: Simple Efecto / Spring Return

Nº	Descripción Description	Cant. Quant.	Material Material
1	TORNILLO ALLEN TAPA CAP ALLEN SCREW	8	ACERO INOX. AISI-316 AISI-316 STAINLESS STEEL
2	TAPA CAP	2	ACERO INOXIDABLE CF8M CF8M STAINLESS STEEL
3	JUNTA TÓRICA TAPA CAP-O-RING	2	N.B.R. N.B.R.
4	ÉMBOLO PISTON	2	POLIARILAMIDA POLYARILAMIDE
5	CILINDRO CYLINDER	1	ACERO INOXIDABLE CF8M CF8M STAINLESS STEEL
6	ARANDELA WASHER	1	POLIAMIDA 6 POLYAMIDE 6
7	ANILLO DE SEGURIDAD SPRING CLIP	1	ACERO INOXIDABLE STAINLESS STEEL
8	INDICADOR VISUAL POSITION INDICATOR	1	POLIAMIDA POLYAMIDE
9	GUIA ÉMBOLO PISTON GUIDE	2	POLIACETAL POLYACETAL
10	ANILLO GUIA GUIDE RING	2	POLIACETAL POLYACETAL
11	JUNTA TÓRICA ÉMBOLO PISTON O-RING	2	N.B.R. N.B.R.
12	JUNTA TÓRICA EJE SHAFT O-RING	2	N.B.R. N.B.R.
13	JUNTA TÓRICA EJE SHAFT O-RING	2	N.B.R. N.B.R.
14	JUEGO MUELLES PRECARGADOS PRELOADED SPRINGS SET	1	DIN-17223-C (2) (4) DIN-17223-C (2) (4)
16	EJE SHAFT	1	ACERO INOX AISI-316 AISI-316 STAINLESS STEEL
17	PIÑÓN GEAR	1	ALEACIÓN ALUMINIO (5) (2) ALUMINIUM ALLOY (5) (2)
18	JUNTA TÓRICA PLACA PLATE O-RING	2	N.B.R. N.B.R.
19	JUNTA TÓRICA TAPA CAP O-RING	2	N.B.R. N.B.R.
20	PLACA CONEXIÓN NEUMÁTICA PNEUMATIC CONNECTION PLATE	1	ACERO INOXIDABLE CF8M CF8M STAINLESS STEEL
21	TORNILLO ALLEN PLACA PLATE ALLEN SCREW	2	ACERO INOXIDABLE AISI-316 AISI-316 STAINLESS STEEL
22	TORNILLO BOLT	2	ACERO INOXIDABLE AISI-316 AISI-316 STAINLESS STEEL
23	TUERCA NUT	2	ACERO INOXIDABLE AISI-316 AISI-316 STAINLESS STEEL
24	ARANDELA BUSHING	2	ACERO INOXIDABLE AISI-316 AISI-316 STAINLESS STEEL
25	JUNTA TÓRICA O-RING	2	N.B.R. N.B.R.
26	LEVA CAM	1	ACERO INOXIDABLE CF8 CF8 STAINLESS STEEL

- (2) RECUBRIMIENTO POR CATAFORESIS.
COVERED BY CATAPHORESIS.
- (4) CANTIDAD VARIABLE, CONSULTAR TABLAS PARES SIMPLE EFECTO.
VARIABLE QUANTITY, PLEASE SEE THE SPRING RETURN TORQUE CHART.
- (5) BRUÑIDO CON BOLAS.
BALL BURNISHING.

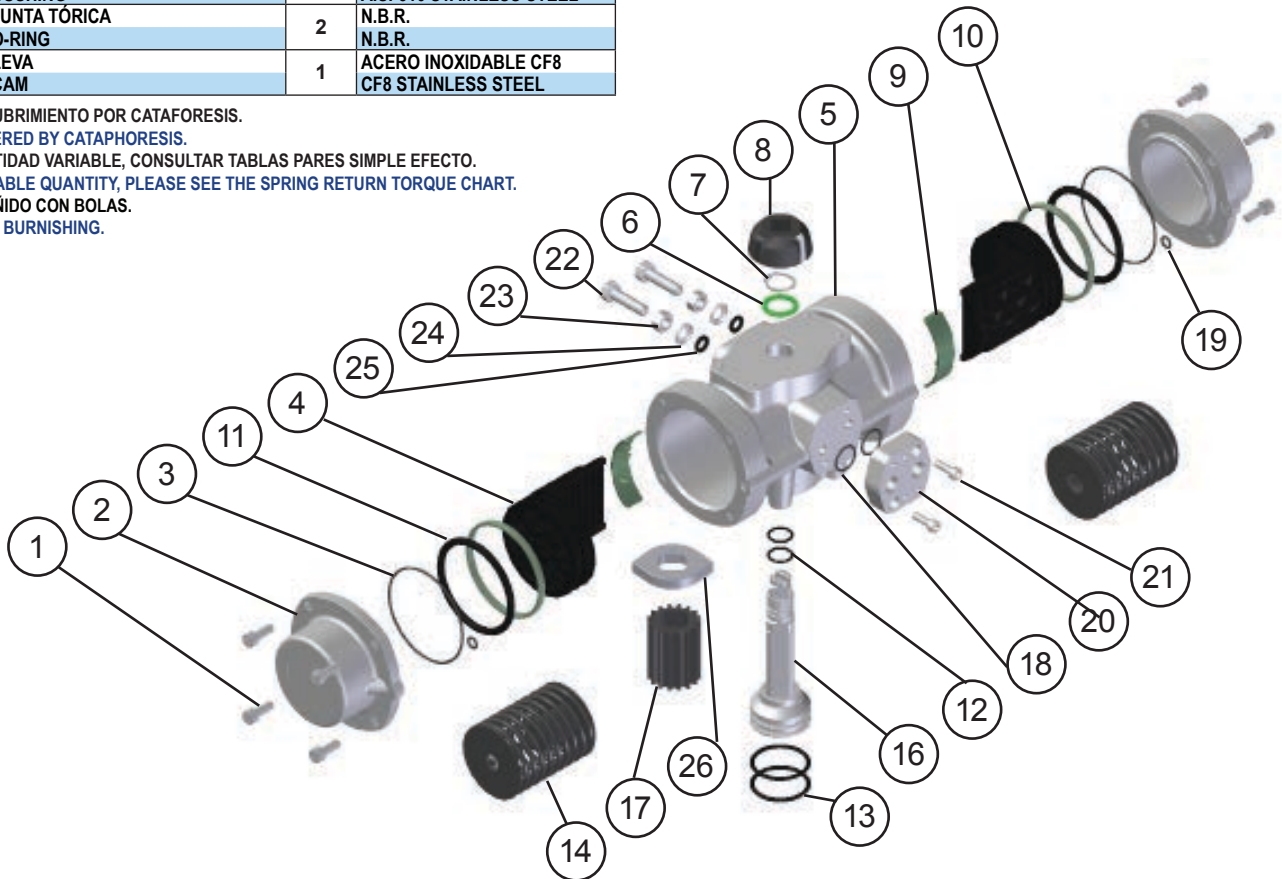

* PI10: SIL3
PI10S: SIL2 / SIL3 (SC)

MODELOS MODELS	TIEMPO DE MANIOBRA EN SEG. CYCLE TIME IN SECS.		PESOS WEIGHTS		CAPACIDAD EN LITROS CAPACITY IN LITRES	
	PARA ABRIR TO OPEN	PARA CERRAR TO CLOSE	Kg.	Lb.	PARA ABRIR TO OPEN	PARA CERRAR TO CLOSE
PI10	0,25	0,25	4,7	10,36	0,35	0,32
PI10S	0,3	0,3	5,6	12,35	0,35	

Tiempo de maniobra sin par resistente a 6 bar.
Cycle time w/o resistant torque at 6 bar.

Dimensiones en mm.
Dimensions in mm.

Para calcular el consumo, multiplicar las cifras del cuadro por la presión real de trabajo.

To calculate the consumption, multiply the above figures by the real working pressure.

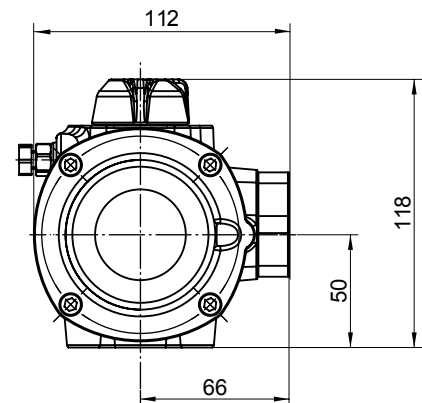
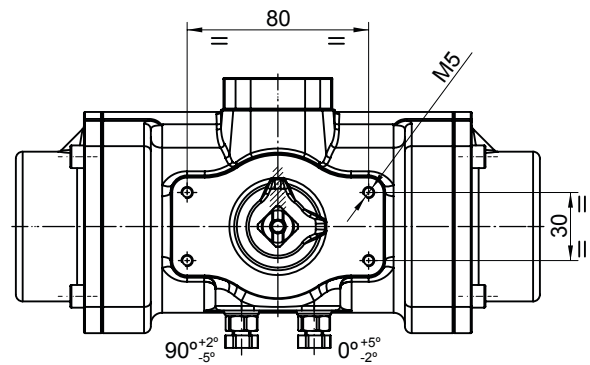
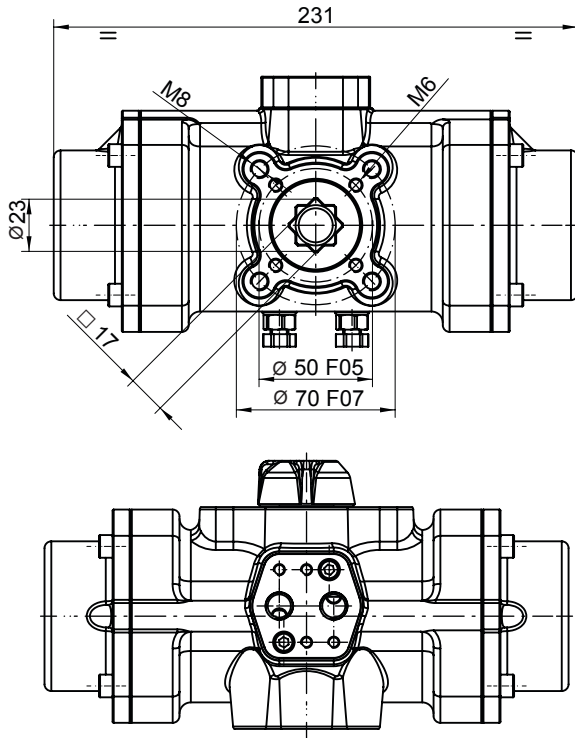

PARES DOBLE EFECTO DOUBLE ACTING TORQUES

PI10	PRESION AIRE AIR PRESSURE								
	bar	3	4	4,5	5	5,5	6	7	8
p.s.i	43,5	58	65,3	72,5	79,8	87	101,5	116	
Nm	32,9	45,6	52	58,3	64,7	71	83,7	96,4	
Lb.in	291,2	403,6	459,8	516	572,6	628,4	740,7	853,1	

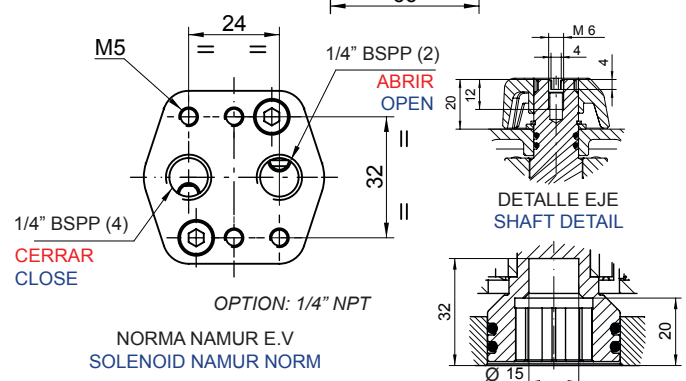

PARES SIMPLE EFECTO SPRING RETURN TORQUES

PI10S	PAR MUELLES SPRING TORQUES		PAR A LA PRESIÓN INDICADA AIR TORQUE AT INDICATED PRESSURE																	
			3		4		4,5		5		5,5		6		7		8		bar	
	INICIAL INITIAL	FINAL END	43,5	58	65,3	72,5	79,8	87	101,5	116										p.s.i
N																				
4*	46,6	32,3					19,7	5,4	26	11,7	32,4	18,1	38,7	24,4	51,4	37,1	64,1	49,8		Nm
	412,4	285,9					173,9	47,4	230,1	103,5	286,7	160,2	342,5	215,9	454,9	328,3	567,3	440,7		Lb.in
3	40,4	28,6					23,4	11,6	29,7	17,9	36,1	24,3	42,4	30,6	55,1	43,3	67,8	56		Nm
	357,5	253,1					206,7	102,3	262,8	158,4	319,5	215,1	375,2	270,8	487,6	383,2	600	495,6		Lb.in
2	28	19,8			25,8	17,7	32,2	24,0	38,5	30,4	44,9	36,7	51,2	43,1	63,9	55,8				Nm
	247,8	175,2			228,3	156,6	284,6	212,0	340,7	269	397,3	324,8	453,1	381,4	56,5	493,8				Lb.in
1	18,7	13	19,9	14,2	32,6	26,9	39,0	33,3	45,4	39,6	51,7	46	58,1	52,3						Nm
	165,5	115,1	176,1	125,7	288,5	238,1	344,7	294,3	401,8	350,5	457,6	407,1	514,2	462,9						Lb.in

N: Número de muelles por banda y posición
Number of springs per side and position

* Número de muelles estándar
* Standard number of springs