

**DESPIECE**

**DISASSEMBLY**

Nº	Descripción Description	Cant. Quant.	Material Material
1	TORNILLO ALLEN TAPA CAP ALLEN SCREW	8	ACERO INOXIDABLE AISI-304 AISI-304 STAINLESS STEEL
2	TAPA CAP	2	ALEACIÓN ALUMINIO (2) + (7) ALUMINIUM ALLOY (2) + (7)
3	JUNTA TÓRICA TAPA CAP-O-RING	2	N.B.R. N.B.R.
4	ÉMBOLO PISTON	2	ALEACIÓN ALUMINIO (2) ALUMINIUM ALLOY (2)
5	CILINDRO CYLINDER	1	ALEACIÓN DE ALUMINIO (2) + (1) ALUMINIUM ALLOY (2) + (1)
6	ARANDELA WASHER	1	POLIACETAL POLYACETAL
7	ANILLO DE SEGURIDAD SPRING CLIP	1	ACERO (3) STEEL (3)
8	INDICADOR VISUAL POSITION INDICATOR	1	POLIAMIDA POLYAMIDE
9	GUIA ÉMBOLO PISTON GUIDE	2	POLIACETAL + Mb POLYACETAL+ Mb
10	ANILLO GUIA GUIDE RING	2	POLIACETAL + Mb POLYACETAL + Mb
11	JUNTA TÓRICA ÉMBOLO PISTON O-RING	2	N.B.R. N.B.R.
12	JUNTA TÓRICA EJE SHAFT O-RING	2	N.B.R. N.B.R.
13	JUNTA TÓRICA EJE SHAFT O-RING	2	N.B.R. N.B.R.
14	MUELLES PRECARGADOS PRELOADED SPRINGS	12	DIN-17223-C (2) (4) DIN-17223-C (2) (4)
15	LEVA CAM	1	ACERO (2) STEEL (2)
16	EJE SHAFT	1	ACERO (2) STEEL (2)
17	JUNTA TÓRICA PLACA PLATE O-RING	2	N.B.R. N.B.R.
18	TUERCA NUT	4	ACERO INOXIDABLE AISI-304 AISI-304 STAINLESS STEEL
19	PLACA CONEXIÓN NEUMÁTICA PNEUMATIC CONNECTION PLATE	1	POLIAMIDA + FV POLYAMIDE + FG
20	TORNILLO ALLEN PLACA PLATE ALLEN SCREW	2	ACERO INOXIDABLE AISI-304 AISI-304 STAINLESS STEEL
21	TORNILLO HEXAGONAL HEXAGONAL SCREW	2	ACERO INOXIDABLE AISI-304 AISI-304 STAINLESS STEEL
22	TUERCA NUT	2	ACERO INOXIDABLE AISI-304 AISI-304 STAINLESS STEEL
23	ARANDELA BUSHING	2	ACERO INOXIDABLE AISI-316 AISI-316 STAINLESS STEEL
24	JUNTA TÓRICA O-RING	2	N.B.R. N.B.R.
25	PIÑÓN GEAR	1	ALEACIÓN ALUMINIO (5) ALUMINIUM ALLOY (5)
26	ARANDELA TAPA CAP WASHER	8	ACERO INOXIDABLE AISI-304 AISI-304 STAINLESS STEEL

- (1) RECUBRIMIENTO CON POLIAMIDA.  
COVERED WITH POLYAMIDE.
- (2) RECUBRIMIENTO POR CATÁFORESIS.  
COVERED BY CATHORESIS.
- (3) RECUBIERTO CON NÍQUEL-TEFLON.  
COVERED BY NIKEL-P.T.F.E.
- (4) CANTIDAD VARIABLE, CONSULTAR  
TABLAS PARES SIMPLE EFECTO.  
VARIABLE QUANTITY, PLEASE SEE THE  
SPRING RETURN TORQUE CHART.
- (5) BRUÑIDO CON BOLAS.  
BALL BURNISHING.
- (7) RECUBRIMIENTO CON POLIURETANO.  
COVERED WITH POLYURETHANE.

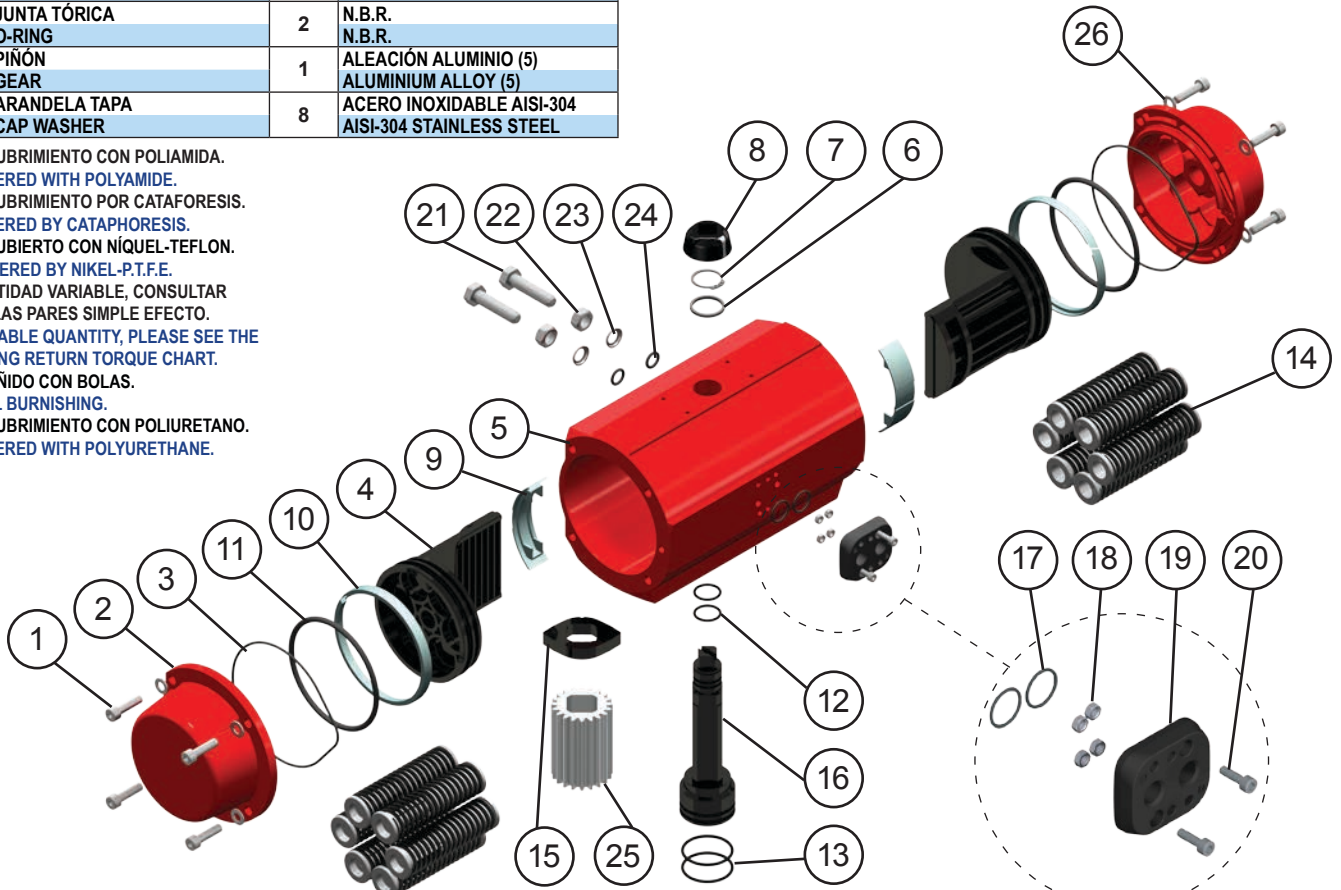

**ACTUADOR NEUMÁTICO DE ALUMINIO  
ALUMINIUM PNEUMATIC ACTUATOR**



**PA25:** Doble Efecto / Double Acting

**PA25S:** Simple Efecto / Spring Return

\* PA25: SIL3  
PA25S: SIL2 / SIL3 (SC)

MODELOS MODELS	TIEMPO DE MANIOBRA EN SEG. CYCLE TIME IN SECS.		PESOS WEIGHTS		CAPACIDAD EN LITROS CAPACITY IN LITRES	
	PARA ABRIR TO OPEN	PARA CERRAR TO CLOSE	Kg.	Lb.	PARA ABRIR TO OPEN	PARA CERRAR TO CLOSE
PA25	0,5	0,5	9,30	20,50	1,5	2,02
PA25S	0,8	0,8	11,30	29,92	1,5	

Tiempo de maniobra sin par resistente a 6 bar.  
Cycle time w/o resistant torque at 6 bar.

Dimensiones en mm.  
Dimensions in mm.

Para calcular el consumo, multiplicar las cifras del cuadro por la presión real de trabajo.

To calculate the consumption, multiply the above figures by the real working pressure.

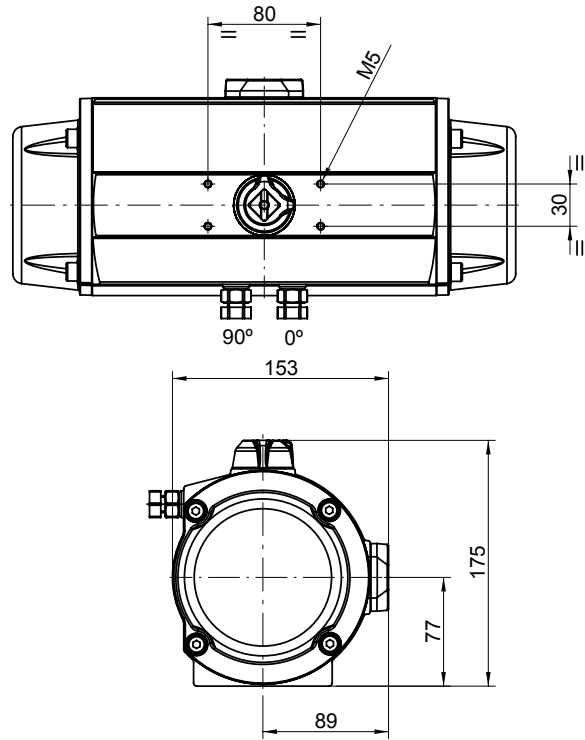
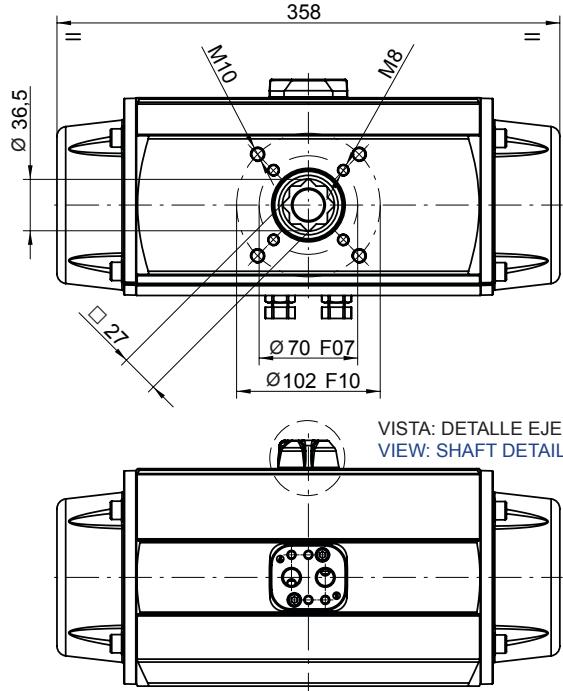

### PARES DOBLE EFECTO DOUBLE ACTING TORQUES

PA25	PRESION AIRE AIR PRESSURE							
bar	3	4	4,5	5	5,5	6	7	8
p.s.i	43,5	58	65,3	72,5	79,8	87	101,5	116
Nm	140,1	190,1	215,1	240	264,9	290	339,9	393,9
Lb.in	1.240	1.683	1.903	2.124	2.345	2.567	3.008	3.486

### PARES SIMPLE EFECTO SPRING RETURN TORQUES

PA25S	PAR MUELLES SPRING TORQUES		PAR A LA PRESIÓN INDICADA AIR TORQUE AT INDICATED PRESSURE																
			3		4		4,5		5		5,5		6		7		8		bar
N	INICIAL INITIAL	FINAL END	INICIAL INITIAL	FINAL END	INICIAL INITIAL	FINAL END	INICIAL INITIAL	FINAL END	INICIAL INITIAL	FINAL END	INICIAL INITIAL	FINAL END	INICIAL INITIAL	FINAL END	INICIAL INITIAL	FINAL END	INICIAL INITIAL	FINAL END	p.s.i
6*	181,8	119,4					95,7	33,3	120,6	58,2	145,5	83,1	170,6	108,2	220,5	158,1	274,5	212,1	Nm
	1.609	1.057					846,5	294,5	1.067	515,1	1.288	735,5	1.510	957,6	1.952	1.399	2.429	1.877	Lb.in
5	151,5	99,5			90,6	38,6	115,6	63,6	140,5	88,5	165,4	113,4	190,5	138,5	240,4	188,4	294,4	242,4	Nm
	1.341	880,6			801,9	341,6	1.023	562,5	1.243	783,3	1.464	1.004	1.686	1.226	2.128	1.667	2.606	2.145	Lb.in
4	121,2	79,6	60,5	18,9	110,5	68,9	135,5	93,9	160,4	118,8	185,3	143,7	210,4	168,8	260,3	218,7	314,3	272,7	Nm
	1.072	704,5	535,5	167,3	978	609,8	1.199	831,5	1.420	1.051	1.640	1.272	1.862	1.494	2.304	1.936	2.782	2.414	Lb.in
3	90,9	59,7	80,4	49,2	130,4	99,2	155,4	124,2	180,3	149,1	205,2	174	230,3	199,1	280,2	249			Nm
	804,5	528,4	711,6	435,5	1.154	878	1.375	1.099	1.596	1.319	1.816	1.540	2.038	1.762	2.480	2.204			Lb.in
2	60,6	39,8	100,3	79,5	150,3	129,5	175,3	154,5	200,2	179,4	225,1	204,3	250,2	229,4					Nm
	536,4	352,3	887,7	703,6	1.330	1.146	1.551	1.367	1.772	1.588	1.992	1.808	2.214	2.030					Lb.in

N: Número de muelles por banda  
Number of springs per side

\* Número de muelles estándar  
\* Standard number of springs

