

# VACUUM PUMPS / VCS pumps

## VCS102

### Features and Strengths

- Built in level compensator in one body
- Highly operational reliability despite fluctuating or low compressed-air pressure
- Quick response time
- Compact size and light weight



### Specifications

Description	VCS102
Max. Vacuum level	-83 kPa
Open Vacuum flow	16 NI/min
Max. Feed pressure	2.2 bar
Temperature	-20 ~ 80 °C
Noise level	50~55 dBA
Weight	28.72 g

### Vacuum Flow

Model	Max. vacuum (-kPa)	Feed Pressure (bar)	Vacuum flow (NI/min) at different vacuum levels (-kPa)									
			0	10	20	30	40	50	60	70	80	90
VCS102	50	1.1	11.5	6.3	2.2	1.6	0.7	-	-	-	-	-
	83	1.8	14.2	9.4	3.3	2.2	2	1.4	0.8	0.4	0.18	-
	83	2.2	16	11.9	5.1	2.3	1.4	1.3	0.9	0.3	0.12	-

### Evacuation Time

Model	Feed Pressure (bar)	Air Consumption (NI/min)	Evacuation time in sec / liter to reach different vacuum levels (-kPa)									
			10	20	30	40	50	60	70	80	90	
VCS102	1.1	5.9	0.68	3	6.1	11.8	27.2	-	-	-	-	
	1.8	8.2	0.4	1.48	4.3	6.9	9.1	15.3	27.4	50.2	-	
	2.2	10	0.34	1.6	3.9	7	10.4	17.5	30.9	61.4	-	



## Dimensions – VCS102 series

[Unit : mm]

VCS102-LM5  
VCS102C-LM5 (C type)

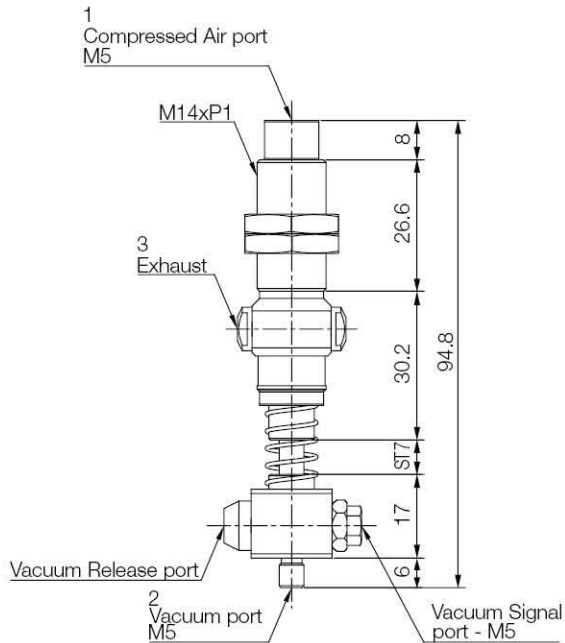

VCS102-LM5 07  
VCS102C-LM5 07 (B type)

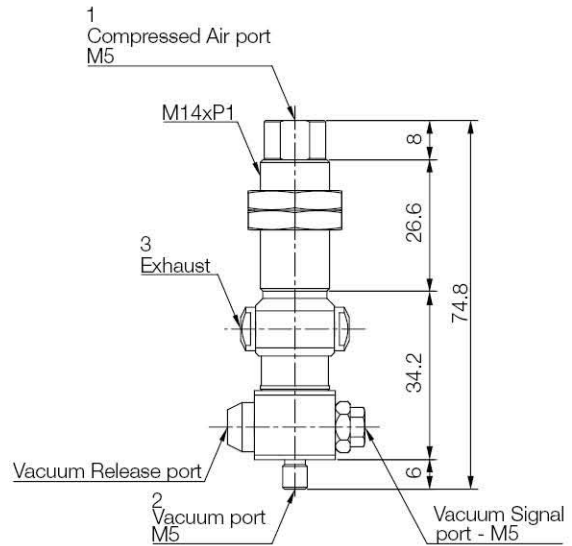

VCS102-L18F (D type)

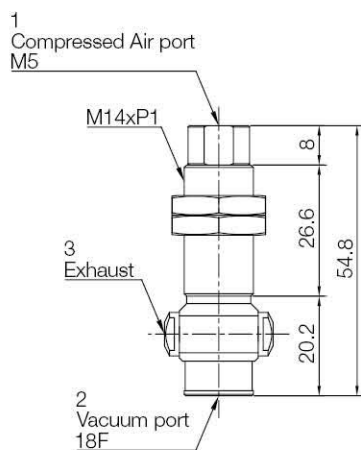

# VACUUM PUMPS / VCS pumps

## Build an Ordering No.

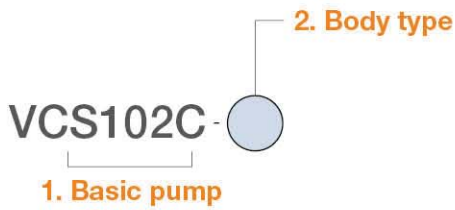

1. Basic pump	Description	Symbol
	Vacuum speeder VCS102 series, 2-stage cartridge, No release check valve	VCS102
	Vacuum speeder VCS102 series, 2-stage cartridge, Release check valve	VCS102C
2. Body type	Description	Symbol
	Port size M5 male	LM5
	Port size M5 male, Level compensator 7mm	LM507
	Port size G1/8" female: Only available with VCS102	L18F

## Spare Parts – Basic pumps

Part No.	Description	Weight (g)
VCS102-LM5	Vacuum speeder VCS102 series, 2-stage cartridge, No release check valve, Port size M5 male	43
VCS102-LM507	Vacuum speeder VCS102 series, 2-stage cartridge, No release check valve, Port size M5 male, Level compensator 7mm	47
VCS102-L18F	Vacuum speeder VCS102 series, 2-stage cartridge, No release check valve, Port size G1/8" female	28.72
VCS102C-LM5	Vacuum speeder VCS102 series, 2-stage cartridge, Release check valve, Port size M5 male	45
VCS102C-LM507	Vacuum speeder VCS102 series, 2-stage cartridge, Release check valve, Port size M5 male, Level compensator 7mm	46

## Spare Parts – Cartridges

Part No.	Description
VC102	Micro vacuum cartridge, 2-Stage