

## V - GRIP Constructions

### Series

#### G SERIES

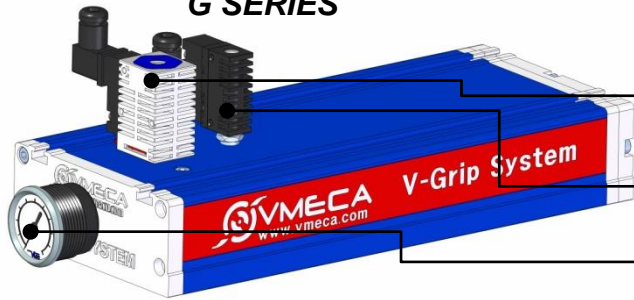

- **Integrated Vacuum Pump**

Air Control Valve - G1/4", G3/8"

Vacuum Release Valve - G1/8", G1/4"

Vacuum Gauge & Switch

#### GF SERIES

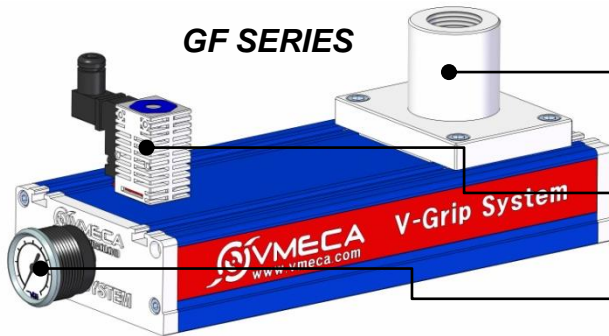

- **Without Vacuum Pump**  
(for External Vacuum Pump)

Vacuum Connect Flange - G1"

Vacuum Release Valve - G1/8", G1/4"

Vacuum Gauge & Switch

### Check Valve Module



*Standard ES*

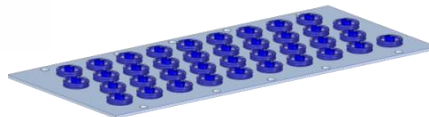

*Adjustable AW*

- **Check Valve Module**

- Perfect closure of idle vacuum port

- Optional adjustable check valve holes are adjustable according to handling products

- Handles porous and non-porous materials

- Integrated filter

### Soft Form

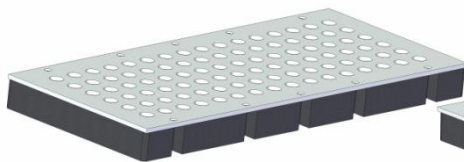

*Standard ES*

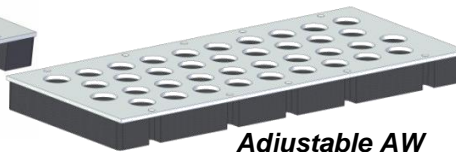

*Adjustable AW*

- **Flexible Sealing Foam**

- Excellent gripping on both even and uneven surface

- Durability

- Easy Installation and Replacement

### Suction Cup

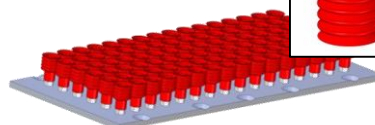
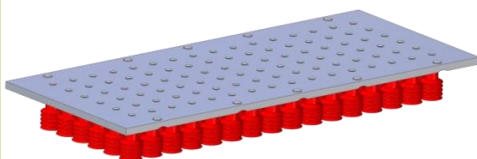

- **Variable Suction Pad**

- Various Pad size / Material

- Durability

- Easy maintenance

( Each Pad is replaceable separately)

## Structure

*V-Grip* G/GF Series are integrated with the Check Valve Module to be able to cope with various surface and applications..

### G SERIES

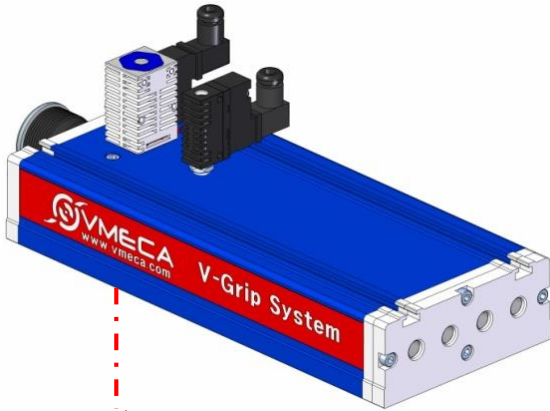

### GF SERIES

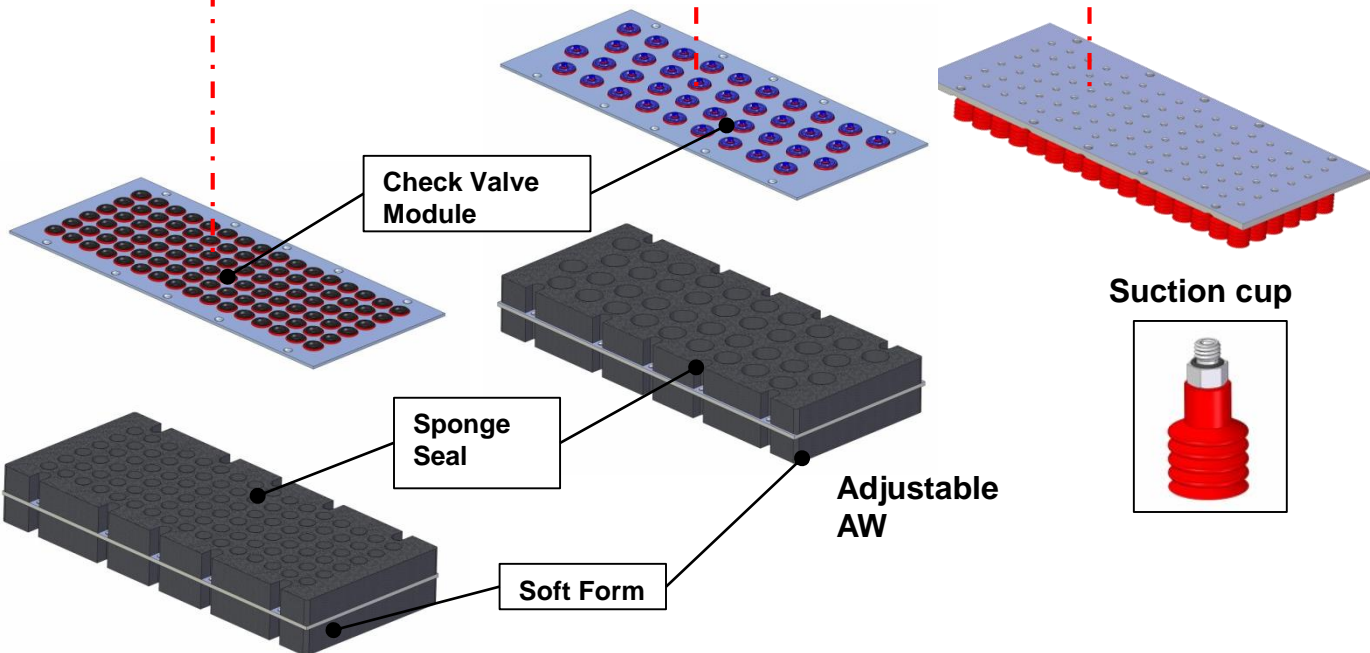
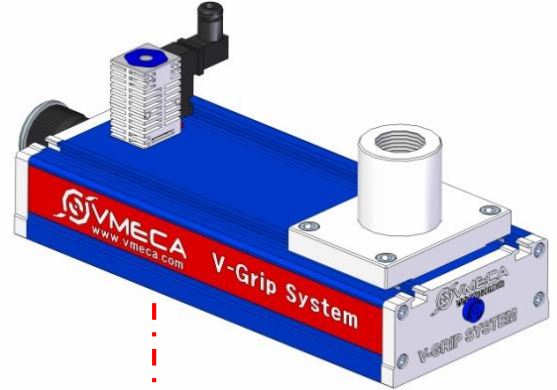

**Standard  
ES**



## Various Suction Cups

V-Grip is excellent gripping both even and uneven surface product. There are optional Standard, Adjustable or Suction Cup Array types that are available.

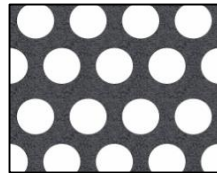
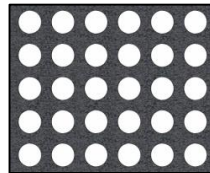
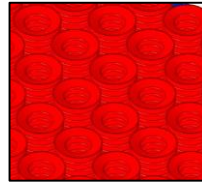

### • Suction Cup Array Type PAD

- Selectable Suction Cup Types and Quantity
- Easy Maintenance (Easy Replacement)

### • Standard Type (ES) Soft Sealing Form

- Available for standard check valves
- Consist of many  $\Phi 12$  holes
- Strong holding force with divided large vacuum port.
- 20mm thick flexible sealing foam

### • Adjustable Type (AW) Soft Sealing Form

- Available for adjustable check valve type
- Consist of many  $\Phi 20$  holes
- Efficiency vacuum control with Adjustable Vacuum Check Valves
- 20mm thickness flexible sealing foam

## Vacuum pump for GF Series

Various VMECA vacuum pumps are attachable to GF series V-Grip systems depending on the application.

### ■ Various vacuum pump for GF series



**TURTLE PUMP**



**PREMIUM PUMP**



**CLASSIC PUMP**



**MEGA PUMP**



**MAX FLEX PUMP**



**MD PUMP**



## Check Valves Features

VMECA V-Grip is designed to work perfectly with the aid of a check valve located in each orifice

### Standard Check Valve

Vacuum – Check valve moves up allowing vacuum to only be drawn through the middle port  
 Vacuum Release – Check valve moves down allowing air to escape from the sides and middle

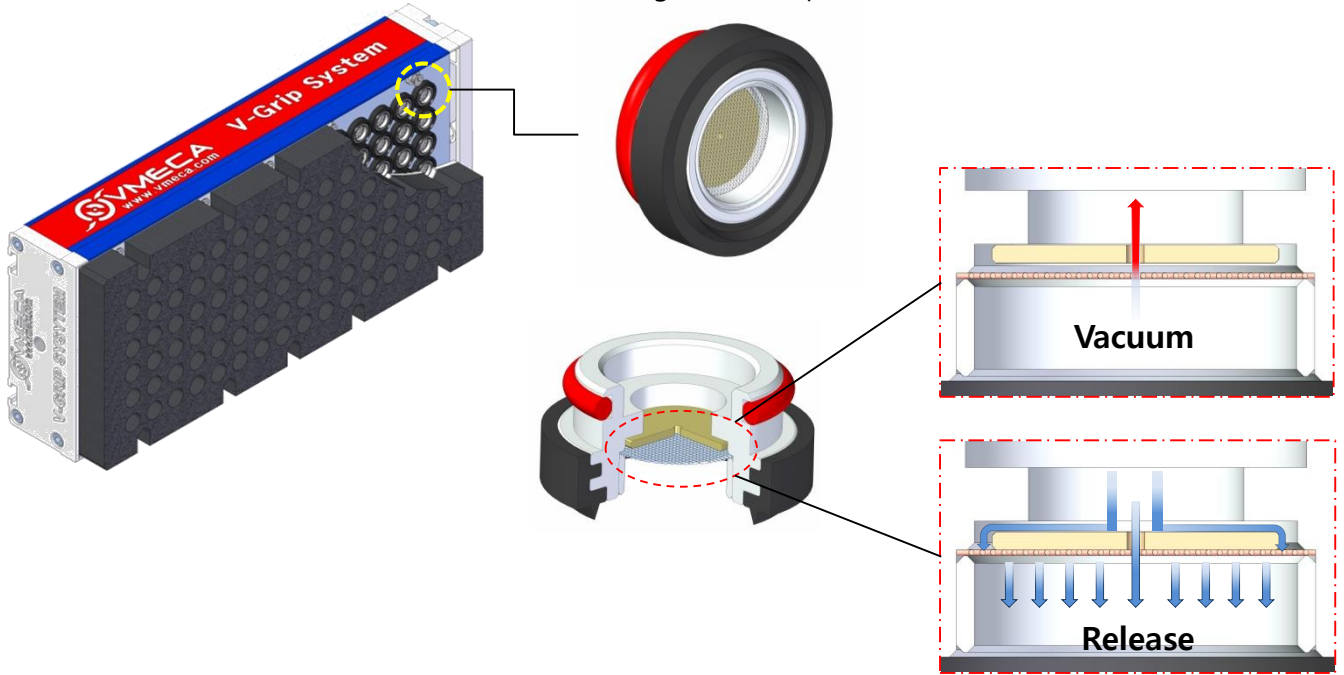

### Adjustable Check Valve

Depending on the different shapes and features, the vacuum flow rate is adjustable to fully adapt to your application

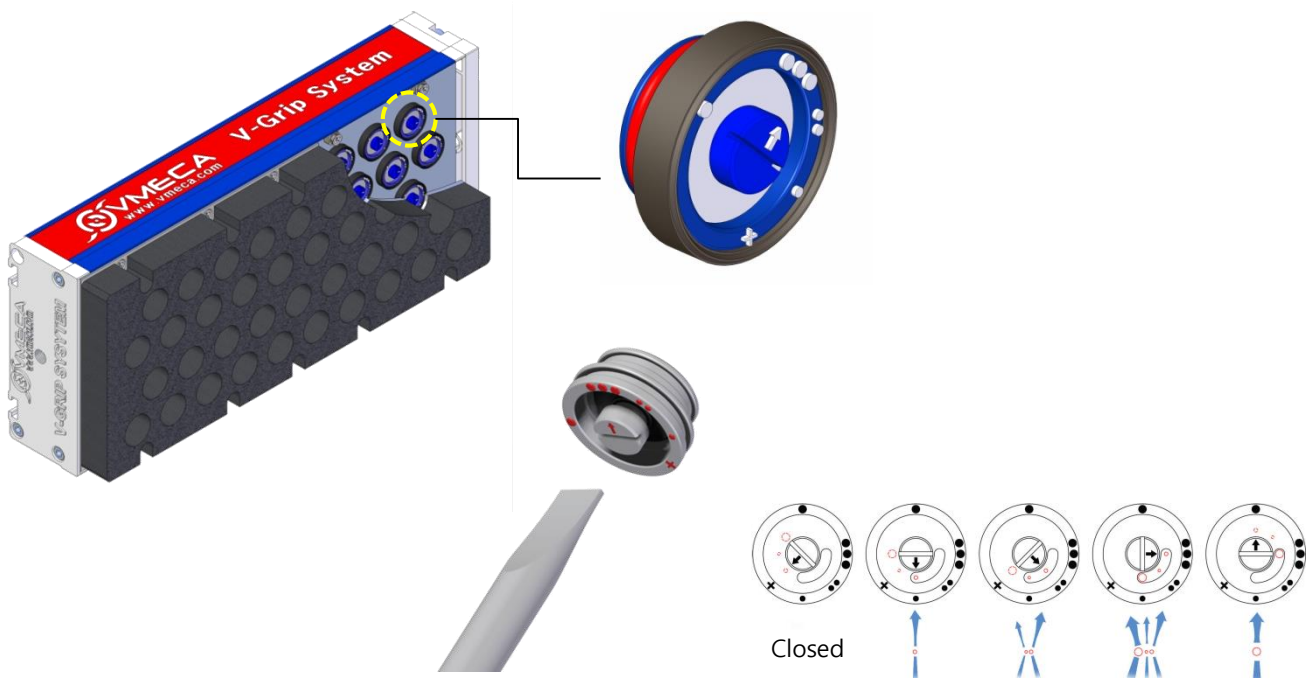

## V - GRIP Application

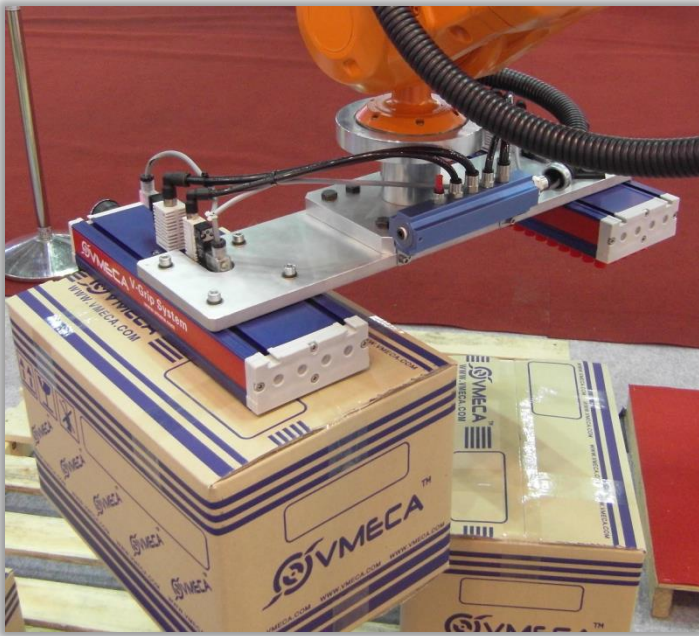

## G 80 Series

<b>Max. vacuum level</b>	: - 75 kPa (-563 mmHg) - 85 kPa (-638 mmHg)
<b>Max. flow rate</b>	: 724 NI/min (25.4 scfm)
<b>Supply air pressure</b>	: 4 ~ 6bar, max 7bar (58~87psi, Max.101.5 psi)
<b>Air consumption</b>	: 208 NI/min (14.6 scfm)
<b>Supply air type</b>	: Dry compressed air
<b>Working temperature</b>	: - 20°C ~ 80°C (-4°F ~ 176°F)
<b>Noise level</b>	: 55 ~ 65 dBA



### Features

- ✓ Handles various products with different shapes, sizes and porous material
- ✓ Flexible sealing foam(EPDM) sponge pad to excellent grip.
- ✓ Adjustable check valve available
- ✓ Durable and light weight aluminum body frame
- ✓ Easy Installation and low maintenance

### Ordering Information

## G 80 X 250 - LC2 - E S - A3 R3 DN - G

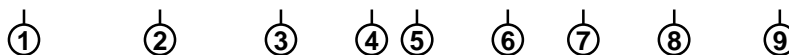

#### ① G Series (width)

G 80	-	84mm
------	---	------

#### ② Length

150	-	150mm
200	-	200mm
220	-	220mm
250	-	250mm
300	-	300mm

#### ⑧ Solenoid Terminal

DN	-	DIN type without lead wire
DL	-	DIN type with lamp without lead wire
CL	-	Connector Type with lamp & 0.3 m lead wire

#### ③ Vacuum Cartridge Type

	Feed Pressure MPa ( psi )	Max Vacuum -kPa ( -mmHg )	Max Vacuum flow NI/min ( scfm )
MC2	0.4 (58)	85 (638)	171.6 (1.73)
LC2	0.6 (87)	75 (563)	400 (4.03)
L2	0.6 (87)	75 (563)	724 (7.3)

Cartridge's selection according to the length (No②)

MC2 : 150 ~ 200 (VC203)  
LC2 : 220 ~ 250 (VCL302)  
L2 : 300 (VCL303)

#### ④ Check Valve

E	-	Standard
A	-	Adjustable

#### ⑤ Port Spacing

S	-	Narrow
W	-	Wide

#### ⑨ Vacuum Switch

G	-	Dial Gauge Attached (VTG-18)
-	-	Not attached
S2(P)	-	Digital output 2 points, No analog supply M8-4Pin male connector (0.3m lead wire)
SG2(P)	-	Digital output 2 points, No analog supply (Grommet type 4 core, 2m lead wire)
SG3(P)	-	Digital output 2 points, Analog Supply (Grommet type 5 core, 2m lead wire)

※Mark : ① S, (P)

L Output type : PNP open collector

②VC M8-4-2 : M8-4 pin female connector  
Option for 'S2' or 'S2P'

#### ⑥ Air Control Valve

A1	-	G1/4", N/C, AC110V
A2	-	G1/4", N/C, AC220V
A3	-	G1/4", N/C, DC24V

#### ⑦ Release Valve

R1	-	G1/8", N/C, AC110V
R2	-	G1/8", N/C, AC220V
R3	-	G1/8", N/C, DC24V

※ Remark : VMS18D Valve only



## G80 Series Characteristics

Model	Air inlet Pressure Mpa (psi)	Air consumption N/m (scfm)	Max. Vacuum Flows N/m (scfm)	Max. Vacuum level -kPa (-mmHg)
G 80 X 150 MC2 ES...	0.4 (58)	64 (2.24)	171.6 (6)	85 (637.6)
G 80 X 200 MC2 ES...	0.4 (58)	64 (2.24)	171.6 (6)	85 (637.6)
G 80 X 220 LC2 ES...	0.6 (87)	208 (7.28)	400 (14)	75 (563)
G 80 X 250 LC2 ES...	0.6 (87)	208 (7.28)	400 (14)	75 (563)
G 80 X 300 L2 ES...	0.6 (87)	208 (7.28)	724 (25.4)	75 (563)

## G80 Series Holding Force (N) Ratio according to Length (mm)

### Standard (ES TYPE)

Model	Holding force at 40% Sealing (N)	Holding force at 60% Sealing (N)	Holding force at 80% Sealing (N)	Holding force at 100% Sealing (N)	Weight Kg
G 80 X 150 MC2 ES...	48.0	52.7	113.7	290.1	1
G 80 X 200 MC2 ES...	65.7	90.2	180.1	427.5	1.38
G 80 X 220 LC2 ES...	107.8	144.3	239.9	555.4	1.48
G 80 X 250 LC2 ES...	138.4	190.1	344.2	663.0	1.62
G 80 X 300 L2 ES...	198.9	248.9	389.8	798.2	1.84

### Adjustable (AW TYPE)

Model	Holding force at 40% Sealing (N)*	Holding force at 60% Sealing (N)*	Holding force at 80% Sealing (N)*	Holding force at 100% Sealing (N)*	Weight Kg
G 80 X 150 MC2 AW...	28.4	23.3	94.1	241.1	0.8
G 80 X 200 MC2 AW...	46.1	60.8	160.5	378.5	1.24
G 80 X 220 LC2 AW...	88.2	114.9	220.3	506.4	1.4
G 80 X 250 LC2 AW...	118.8	160.7	324.6	614.0	1.55
G 80 X 300 L2 AW...	179.3	219.5	370.2	749.2	1.8

\*Note : Actual Figure may be different according to the surface and porosity of product .



## G80 Series Holding Force(N) according to Length(mm)

### ► ES Type

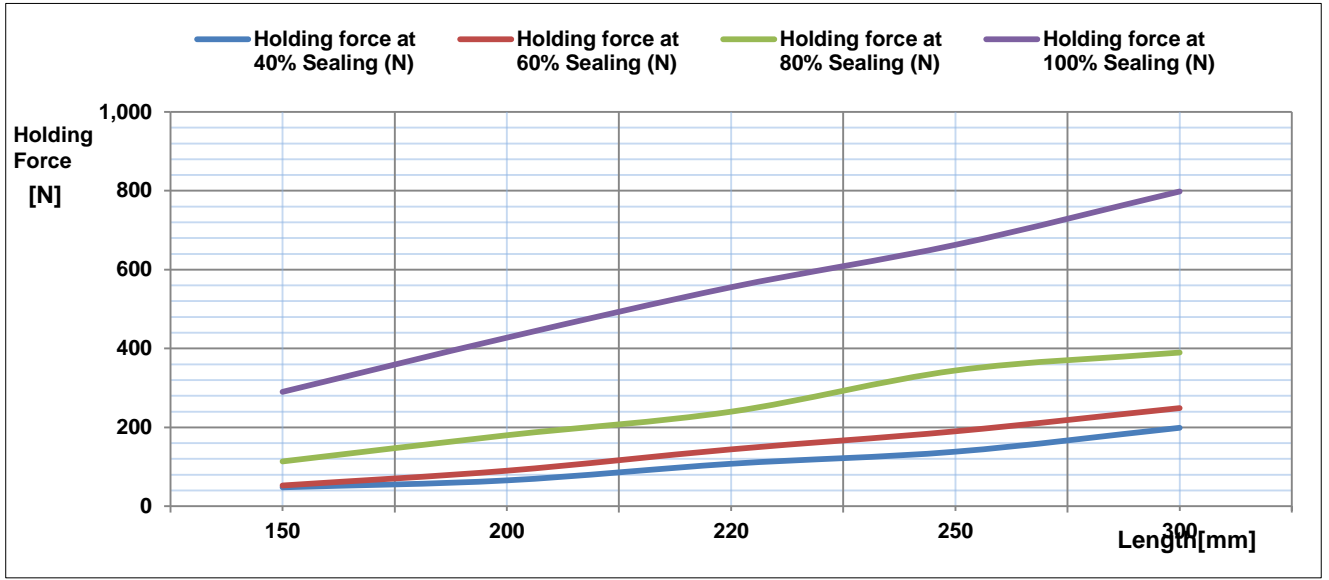

### ► AW Type

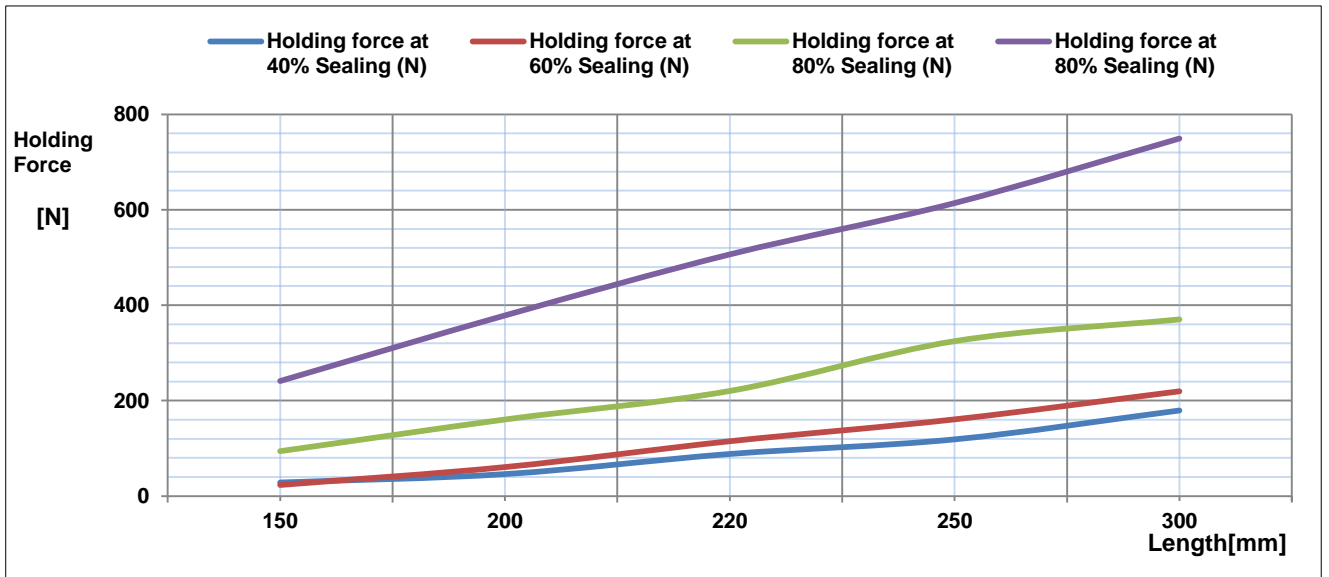

## G80 Series Weight (kg) according to Length (mm)

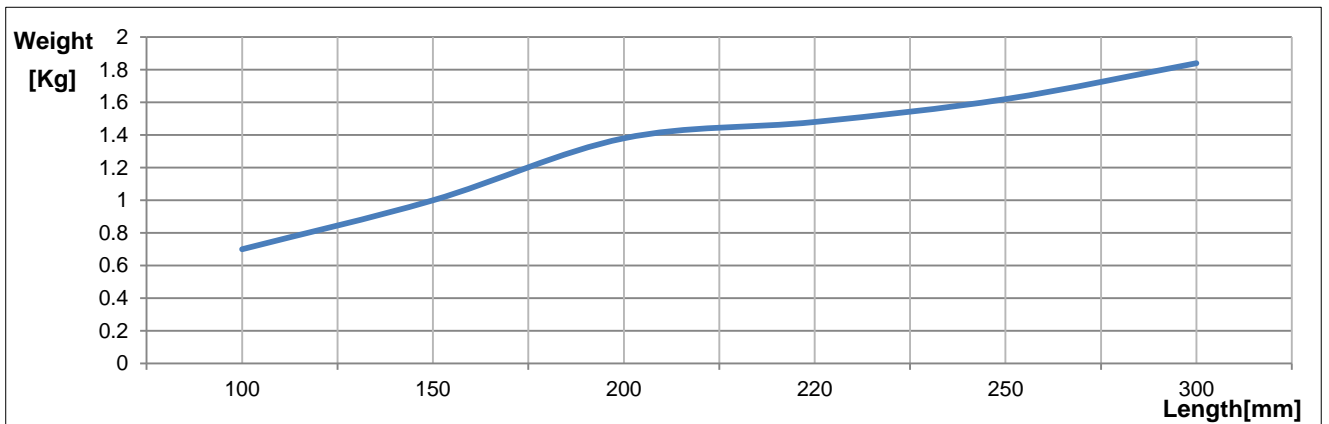



## Dimensions

### ▼ G 80 ... Series (150~300)

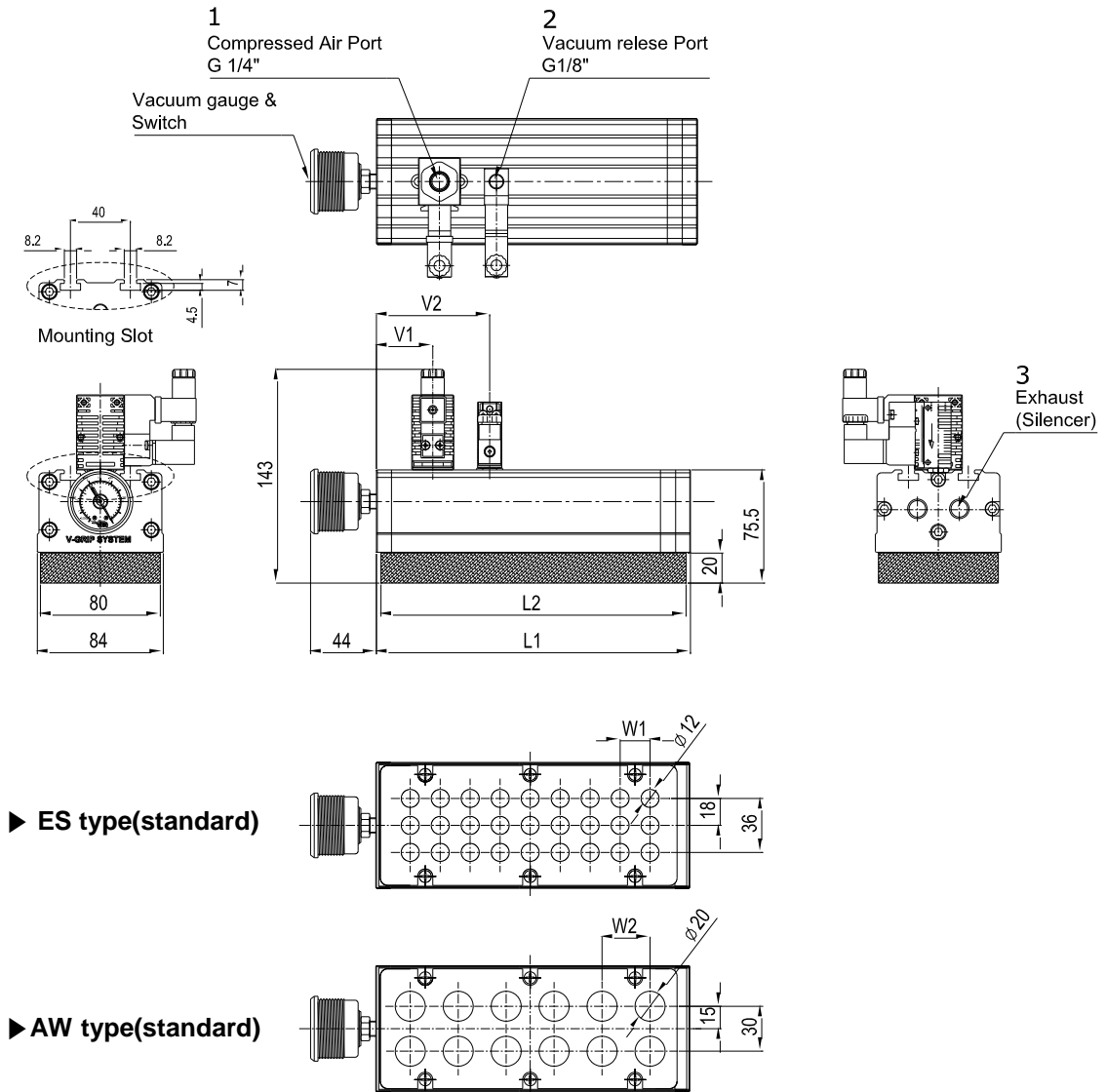

Measure unit : mm

Model	Length	Sponge Pad length	Standard vacuum port (Φ12)		Adjustable Vacuum Port (Φ20)		Air Control Valve		Release valve	
	L1	L2	Port Number	W1	Port Number	W2	V1	Type	V2	Type
G 80 X 150...	168	150	21	20	7	25	30	VMS14	136	VMS18D
G 80 X 200...	214	200	27	20	12	34	80	VMS14	121	VMS18D
G 80 X 220...	234	220	30	20	14	30	42	VMS14	83	VMS18D
G 80 X 250...	264	250	36	20	16	30	72	VMS14	113	VMS18D
G 80 X 300...	314	300	48	18	20	28	42	VMS14	80	VMS18D



## G 130 Series

Max. vacuum level	: - 75 kPa (-563 mmHg)
Max. flow rate	: 2,896 NI/min (101.4 scfm)
Supply air pressure	: 4 ~ 6bar, max 7bar (58~87psi, Max.101.5 psi)
Air consumption	: 832 NI/min (29.1 scfm)
Supply air type	: Dry compressed air
Working temperature	: - 20°C ~ 80°C (-4°F ~ 176°F)
Noise level	: 55 ~ 65 dBA



### Features

- ✓ Handles various products with different shapes, sizes and porous material
- ✓ Flexible sealing foam(EPDM) sponge pad to excellent grip.
- ✓ Adjustable check valve available
- ✓ Durable and light weight aluminum body frame
- ✓ Easy Installation and low maintenance

## Ordering Information

### G 130 X 300 - L4 - E S - A3 R3 DN - G

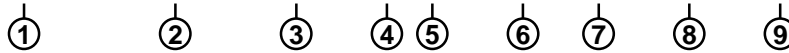

- ① **G Series (width)**
- **G 130** - 134mm
- ② **Length**
- 220 - 220mm
  - 300 - 300mm
  - 400 - 400mm
  - 600 - 600mm
  - 800 - 800mm
  - 1000 - 1000mm
  - 1200 - 1200mm
- ⑦ **Release Valve**
- R1 - N/C, AC110V
  - R2 - N/C, AC220V
  - R3 - N/C, DC24V
- Valve's type according to the length (No②)  
Under 600mm : VMS18D  
Over 600mm : VMS14
- ⑧ **Solenoid Terminal**
- DN - DIN type without lead wire
  - DL - DIN type with lamp without lead wire
  - Connector Type with
  - CL - lamp & 0.3 m lead wire

③ **Vacuum Cartridge Type**

	Feed Pressure MPa ( psi )	Max Vacuum Level -kPa ( -mmHg )	Max Vacuum flow NI/min ( scfm )
L2	0.6 (87)	75 (563)	724 (-25.6)
L3	0.6 (87)	75 (563)	1,086 (-38.4)
L4	0.6 (87)	75 (563)	1,448 (-51.1)
L5	0.6 (87)	75 (563)	1,810 (-63.9)
L6	0.6 (87)	75 (563)	2,172 (-76.7)
L7	0.6 (87)	75 (563)	2,534 (-89.5)
L8	0.6 (87)	75 (563)	2,896 (-102.3)

Cartridge's selection according to the length (No②) : 220mm: LC2 ~ LC4 (VCL302)  
300~ 500mm: L2 ~ L4  
600 ~ 1200mm: L2 ~ L8

- ⑨ **Vacuum Switch**
- **G** - Dial Gauge Attached (VTG-18)
  - - - Not attached
  - S2(P) - Digital output 2 points, No analog supply  
M8-4Pin male connector (0.3m lead wire)
  - SG2(P) - Digital output 2 points, No analog supply  
(Grommet type 4 core, 2m lead wire)
  - SG3(P) - Digital output 2 points, Analog Supply  
(Grommet type 5 core, 2m lead wire)

※Mark : ① S..(P)  
L-Output type : PNP open collector  
②VC M8-4-2 : M8-4 pin female connector  
Option for 'S2' or 'S2P'

- ④ **Check Valve**
- **E** - Standard
  - A - Adjustable
- ⑤ **Port Spacing**
- **S** - Narrow
  - W - Wide
- ⑥ **Air Control Valve**
- A1 - N/C, AC110V
  - A2 - N/C, AC220V
  - A3 - N/C, DC24V
  - D1 - Double Solenoid AC110V
  - D2 - Double Solenoid AC220V
  - D3 - Double Solenoid DC24V

A.. : No ③ Restrict according to the vacuum cartridge  
L2 ~ L6: G1/4" : VMS14 Valve  
L7 ~ L8: G3/8" : VMS38 Valve  
D.. : G3/8" Double Solenoid Valve

Double Solenoid Valve is only possible DN, DL type in the No.8

## G130 Series Characteristics

Model	Air inlet Pressure Mpa (psi)	Air consumption N/m (scfm)	Max. Vacuum Flows N/m (scfm)	Max. Vacuum level -kPa (-mmHg)
G 130 X 220 LC4...	0.6 (87)	416 (14.6)	800 (28)	75 (563)
G 130 X 300 L4...	0.6 (87)	416 (14.6)	1,448 (51.1)	75 (563)
G 130 X 400 L4...	0.6 (87)	416 (14.6)	1,448 (51.1)	75 (563)
G 130 X 600 L8...	0.6 (87)	832 (29.1)	2,896 (102.3)	75 (563)
G 130 X 800 L8...	0.6 (87)	832 (29.1)	2,896 (102.3)	75 (563)
G 130 X 1000 L8...	0.6 (87)	832 (29.1)	2,896 (102.3)	75 (563)
G 130 X 1200 L8...	0.6 (87)	832 (29.1)	2,896 (102.3)	75 (563)

## G130 Series Holding Force (N) Ratio according to Length (mm)

### Standard (ES TYPE)

Model	Holding force at 40% Sealing (N)**	Holding force at 60% Sealing (N)**	Holding force at 80% Sealing (N)**	Holding force at 100% Sealing (N)**	Weight (Kg)*
G 130 X 220 LC4 ES...	228	367	602	996	2.0
G 130 X 300 L4 ES...	293	484	869	1,342	2.7
G 130 X 400 L4 ES...	316	549	1,033	1,549	3.3
G 130 X 600 L8 ES...	535	1,445	1,650	2,738	5.3
G 130 X 800 L8 ES...	615	1,597	2,558	4,204	6.7
G 130 X 1000 L8 ES...	676	1,590	2,370	4,410	8.1
G 130 X 1200 L8 ES...	719	2,609	3,682	4,906	9.6

### Adjustable (AW TYPE)

Model	Holding force at 40% Sealing (N)**	Holding force at 60% Sealing (N)**	Holding force at 80% Sealing (N)**	Holding force at 100% Sealing (N)**	Weight (Kg)*
G 130 X 220 LC4 AW...	205	327	518.4	867	1.8
G 130 X 300 L4 AW...	251	498	805	1,402	2.6
G 130 X 400 L4 AW...	266	594	1,392	1,602	3.2
G 130 X 600 L8 AW...	573	1,464	1,630	2,822	5.2
G 130 X 800 L8 AW...	593	1,474	1,897	4,274	6.6
G 130 X 1000 L8 AW...	634	1,483	3,040	4,791	8.1
G 130 X 1200 L8 AW...	999	2,357	3,696	4,827	9.4

\*\* Note : Actual Figure may be different according to the surface and porosity of product .

\* Weight of Flange mount not included.



## G130 Series Holding Force(N) according to Length(mm)

### ► ES Type

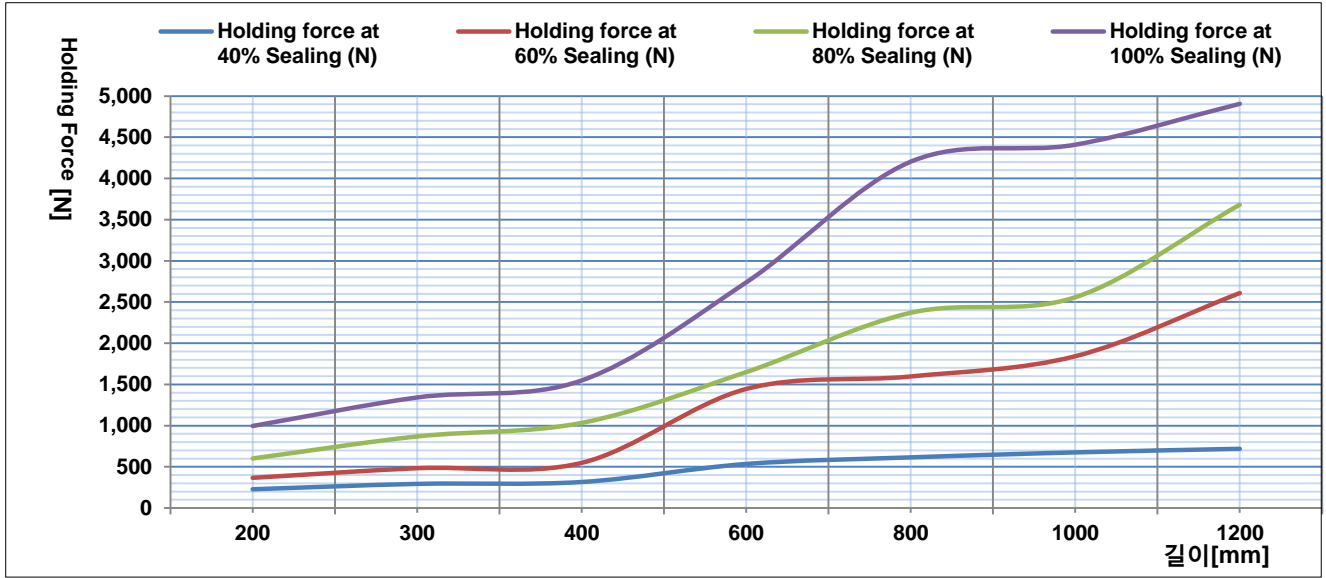

### ► AW Type

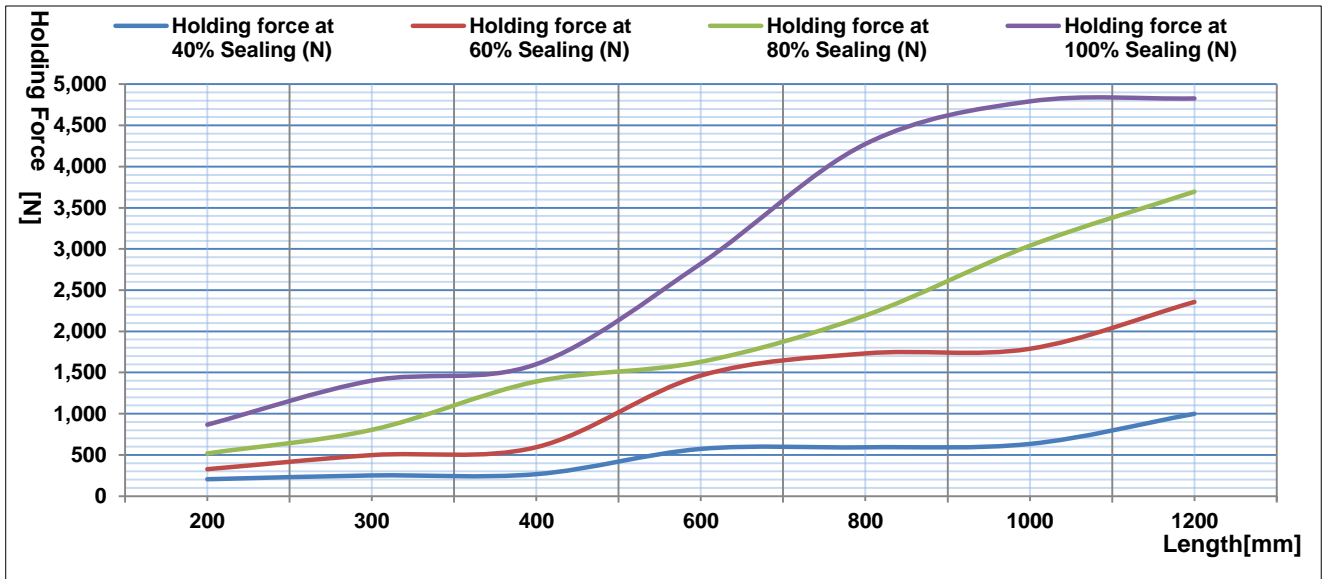

## G130 Series Weight (kg) according to Length (mm)

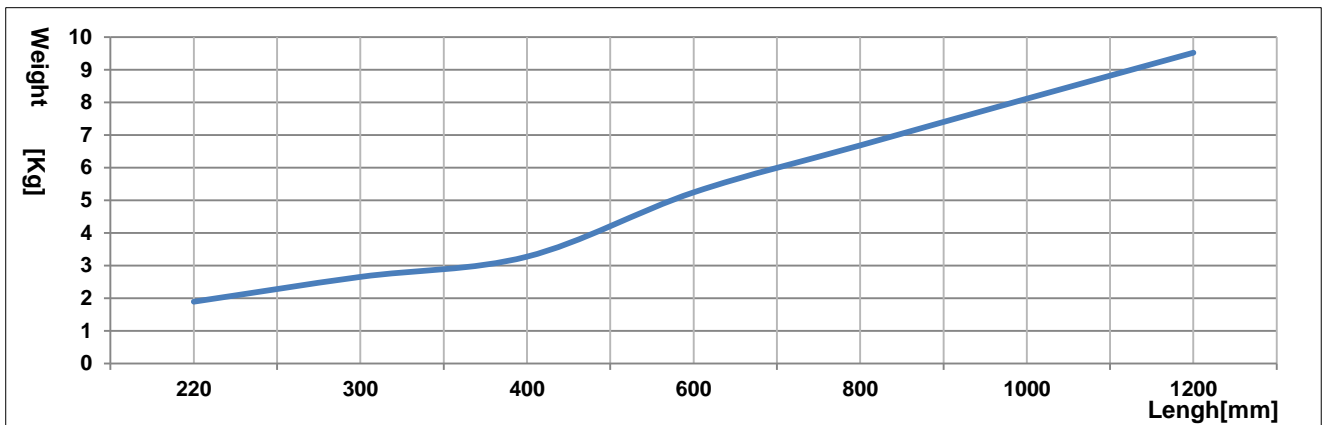

## G130 Series Holding Force(N) according to the Number of Cartridge

※Models G130X400 and under : 2~4 Cartridge possible  
 Models G130X600 and over : 2~8 Cartridge possible

### ► ES Type

220 / 300 / 400

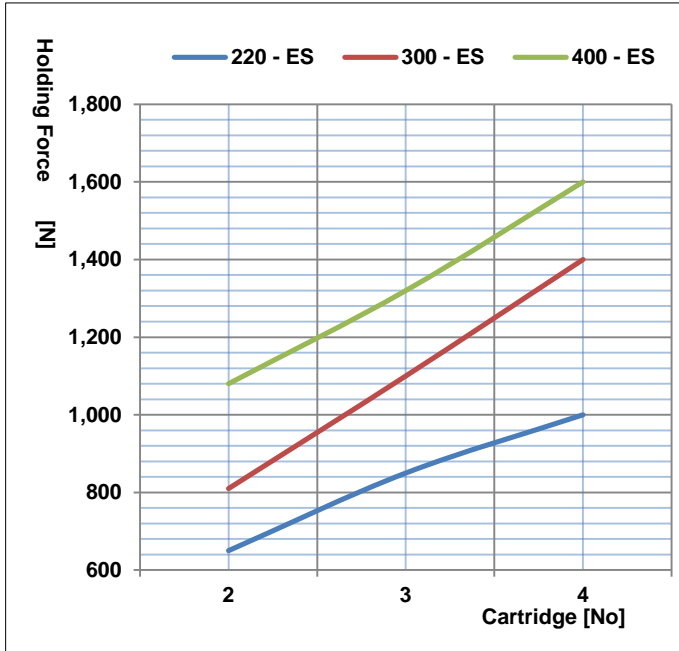

600 / 800 / 1000 / 1200

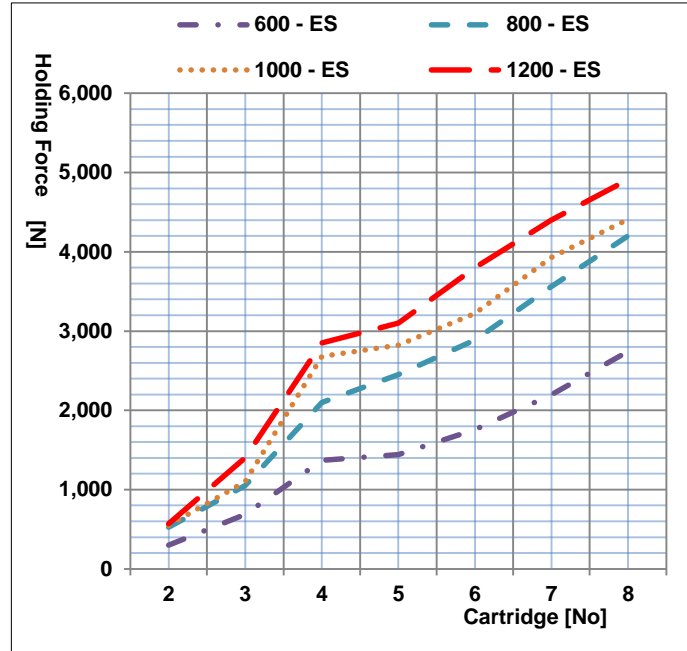

### ► AW Type

220 / 300 / 400

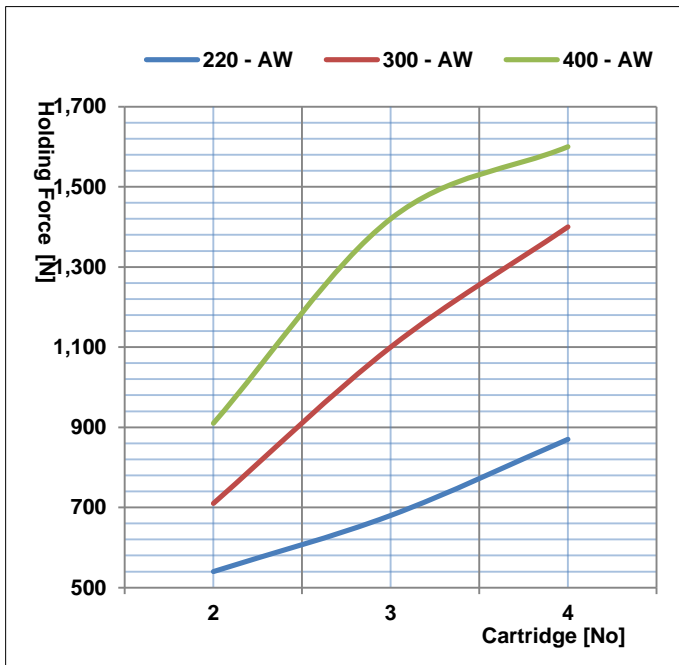

600 / 800 / 1000 / 1200

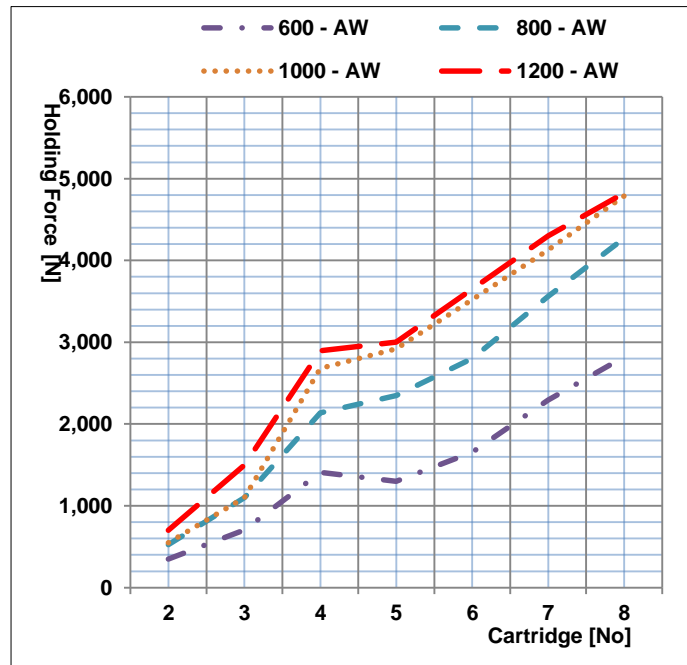

## Dimensions

### ▼ G 130 ... Series(220~400)

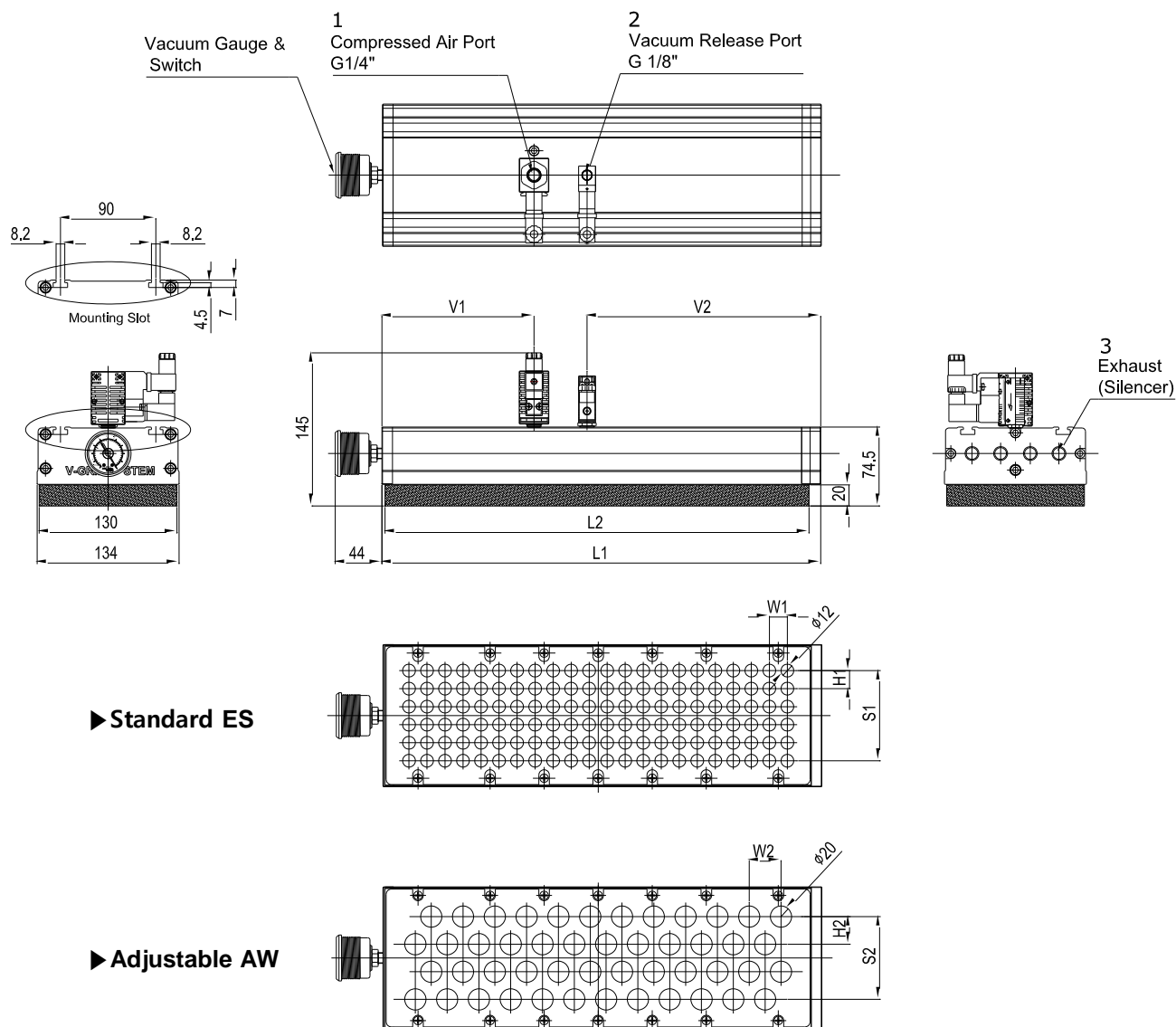

Measure Unit : mm

Model	Length	Sponge Pad length	Standard vacuum port(Φ12)				Adjustable Vacuum Port(Φ20)				Air Control Valve		Release valve	
	L1		L2	No	W1	H1	S1	No	W2	H2	S2	V1	Type	V2
G 130 X 220...	234	220	66	17	17	85	26	28	24	72	43	VMS14	144	VMS18D
G 130 X 300...	314	300	96	17	17	85	38	28	25	78	44	VMS14	221	VMS18D
G 130 X 400...	414	400	132	17	17	85	48	30	26	78	143	VMS14	221	VMS18D



## Dimensions

### ▼ G 130 ... Series(600~1200)

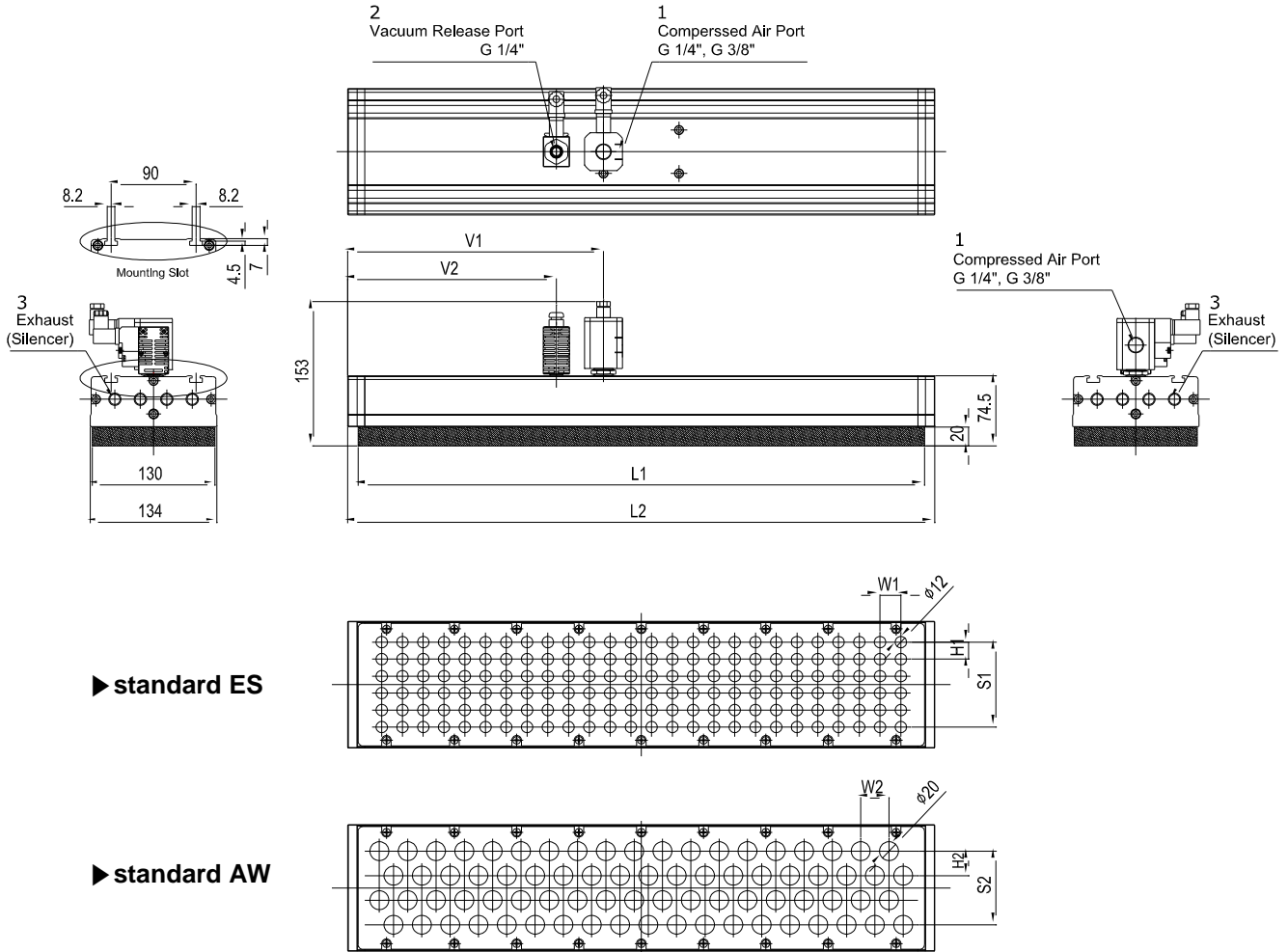

Measure unit : mm

Model	Length	Sponge Pad Length	Standard vacuum port ( $\Phi 12$ )				Adjustable Vacuum Port( $\Phi 20$ )				Air Control Valve		Release valve	
	L1		L2	No	W1	H1	S1	No	W2	H2	S2	V1*	Type**	V2
G 130 X 600...	622	600	156	22	18	90	76	30	26	78	271	VMS14 VMS38	221	VMS14
G 130 X 800...	822	800	210	22	18	90	104	30	26	78	271	VMS14 VMS38	221	VMS14
G 130 X 1000...	1022	1000	264	22	18	90	128	30	26	78	271	VMS14 VMS38	221	VMS14
G 130 X 1200...	1222	1200	324	22	18	90	156	30	26	78	271	VMS14 VMS38	221	VMS14

\* Cartridge 2~4 model : 263mm  
Cartridge 5~8 model : 271mm

\*\* Cartridge 2~6 model : using VMS14 Valve  
Cartridge 7~8 model : using VMS38 Valve



## G 200 Series

Max. vacuum level	: - 75 kPa (-563 mmHg)
Max. flow rate	: 2,896 NI/min (101.4 scfm)
Supply air pressure	: 4 ~ 6bar, max 7bar (58~87psi, Max.101.5 psi)
Air consumption	: 832 NI/min (29.1 scfm)
Supply air type	: Dry compressed air
Working temperature	: - 20°C ~ 80°C (-4°F ~ 176°F)
Noise level	: 55 ~ 65 dBA



### Features

- ✓ Handles various products with different shapes, sizes and porous material
- ✓ Flexible sealing foam(EPDM) sponge pad to excellent grip.
- ✓ Adjustable check valve available
- ✓ Durable and light weight aluminum body frame
- ✓ Easy Installation and low maintenance

## Ordering Information

### G 200 X 300 - L4 - E S - A3 R3 DN - G



① **G Series (width)**

<b>G 200</b>	-	204mm
--------------	---	-------

② **Length**

250	-	250mm
<b>300</b>	-	300mm
400	-	400mm
600	-	600mm
800	-	800mm
1000	-	1000mm
1200	-	1200mm

③ **Vacuum Cartridge Type**

	Feed Pressure MPa ( psi )	Max Vacuum Level -kPa ( -mmHg )	Max Vacuum flow NI/min ( scfm )
L2	0.6 (87)	75 (563)	724(-25.6)
L3	0.6 (87)	75 (563)	1,086(-38.4)
<b>L4</b>	0.6 (87)	75 (563)	1,448(-51.1)
L5	0.6 (87)	75 (563)	1,810(-63.9)
L6	0.6 (87)	75 (563)	2,172(-76.7)
L7	0.6 (87)	75 (563)	2,534(-89.5)
L8	0.6 (87)	75 (563)	2,896(-102.3)

④ **Check Valve**

<b>E</b>	-	Standard
A	-	Adjustable

⑤ **Port Spacing**

<b>S</b>	-	Narrow
W	-	Wide

⑥ **Air Control Valve**

A1	-	N/C, AC110V
A2	-	N/C, AC220V
<b>A3</b>	-	N/C, DC24V
D1	-	Double Solenoid AC110V
D2	-	Double Solenoid AC220V
D3	-	Double Solenoid DC24V

⑦ **Release Valve**

R1	-	N/C, AC110V
R2	-	N/C, AC220V
<b>R3</b>	-	N/C, DC24V

⑨ **Vacuum Switch**

<b>G</b>	-	Dial Gauge Attached (VTG-18)
-	-	Not attached
S2(P)	-	Digital output 2 points, No analog supply M8-4Pin male connector (0.3m lead wire)
SG2(P)	-	Digital output 2 points, No analog supply (Grommet type 4 core, 2m lead wire)
SG3(P)	-	Digital output 2 points, Analog Supply (Grommet type 5 core, 2m lead wire)

⑧ **Solenoid Terminal**

<b>DN</b>	-	DIN type without lead wire
DL	-	DIN type with lamp without lead wire
	-	Connector Type with lamp & 0.3 m lead wire
CL	-	lamp & 0.3 m lead wire

Cartridge's selection according to the length (No.2) : 250mm: LC2 ~ LC4 (VCL302)  
300 ~ 500mm: L2 ~ L4  
600 ~ 1200mm: L2 ~ L8

A.. : No ③ Restrict according to the vacuum cartridge  
L2 ~ L5: G1/4" : VMS14 Valve  
L6 ~ L8: G3/8" : VMS38 Valve  
D.. : G3/8" Double Solenoid Valve

Double Solenoid Valve is only possible DN, DL type in the No.8

※Mark : ① S..(P)  
L Output type : PNP open collector  
② VC M8-4-2 : M8-4 pin female connector  
Option for 'S2' or 'S2P'



## G200 Series Characteristics

Model	Air inlet Pressure Mpa (psi)	Air consumption N/m (scfm)	Max. Vacuum Flows N/m (scfm)	Max. Vacuum level -kPa (-mmHg)
G 200 X 250 LC4...	0.6 (87)	416 (14.6)	800 (28)	75 (563)
G 200 X 300 L4...	0.6 (87)	416 (14.6)	1,448 (51.1)	75 (563)
G 200 X 400 L4...	0.6 (87)	416 (14.6)	1,448 (51.1)	75 (563)
G 200 X 600 L8...	0.6 (87)	832 (29.1)	2,896 (102.3)	75 (563)
G 200 X 800 L8...	0.6 (87)	832 (29.1)	2,896 (102.3)	75 (563)
G 200 X 1000 L8...	0.6 (87)	832 (29.1)	2,896 (102.3)	75 (563)
G 200 X 1200 L8...	0.6 (87)	832 (29.1)	2,896 (102.3)	75 (563)

## G200 Series Holding Force (N) Ratio according to Length (mm)

### Standard (ES TYPE)

Model	Holding force at 40% Sealing (N)	Holding force at 60% Sealing (N)	Holding force at 80% Sealing (N)	Holding force at 100% Sealing (N)	Weight (Kg)*
G 200 X 250 LC4 ES...	343.7	621.8	1180.9	2042.6	2.8
G 200 X 300 L4 ES...	500.3	795.0	1565.3	2807.5	3.5
G 200 X 400 L4 ES...	539.2	901.8	1800.1	3407.0	4.4
G 200 X 600 L8 ES...	913.2	2375.8	2880.2	5962.3	7.1
G 200 X 800 L8 ES...	1049.1	2625.1	4118.6	9658.9	8.6
G 200 X 1000 L8 ES...	1152.3	3028.7	4489.3	10141.8	10.1
G 200 X 1200 L8 ES...	1226.7	4288.9	6509.5	11358.9	12.5

### Adjustable (AW TYPE)

Model	Holding force at 40% Sealing (N)	Holding force at 60% Sealing (N)	Holding force at 80% Sealing (N)	Holding force at 100% Sealing (N)	Weight (Kg)*
G 200 X 250 LC4 AW...	245.7	523.8	1033.9	1959.0	2.8
G 200 X 300 L4 AW...	402.3	697.0	1418.3	2764.3	3.6
G 200 X 400 L4 AW...	462.6	871.3	2070.7	2985.5	4.4
G 200 X 600 L8 AW...	925.3	2195.6	2899.0	6120.2	7.0
G 200 X 800 L8 AW...	990.0	2415.2	3652.8	8751.9	7.5
G 200 X 1000 L8 AW...	1059.3	2536.0	5113.9	9277.1	8.9
G 200 X 1200 L8 AW...	1694.9	3322.1	6443.5	9555.4	11.5

\*\* Note : Actual Figure may be different according to the surface and porosity of product .

\* Weight of Flange mount not included.



## G200 Series Holding Force(N) according to Length(mm)

### ► ES Type

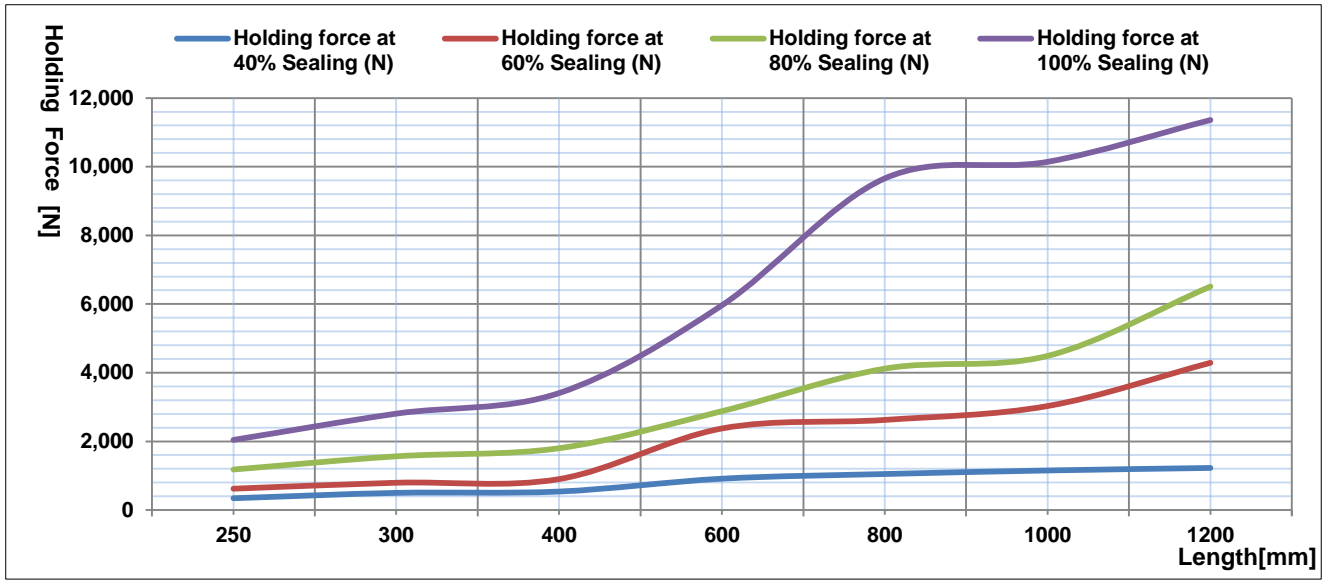

### ► AW Type

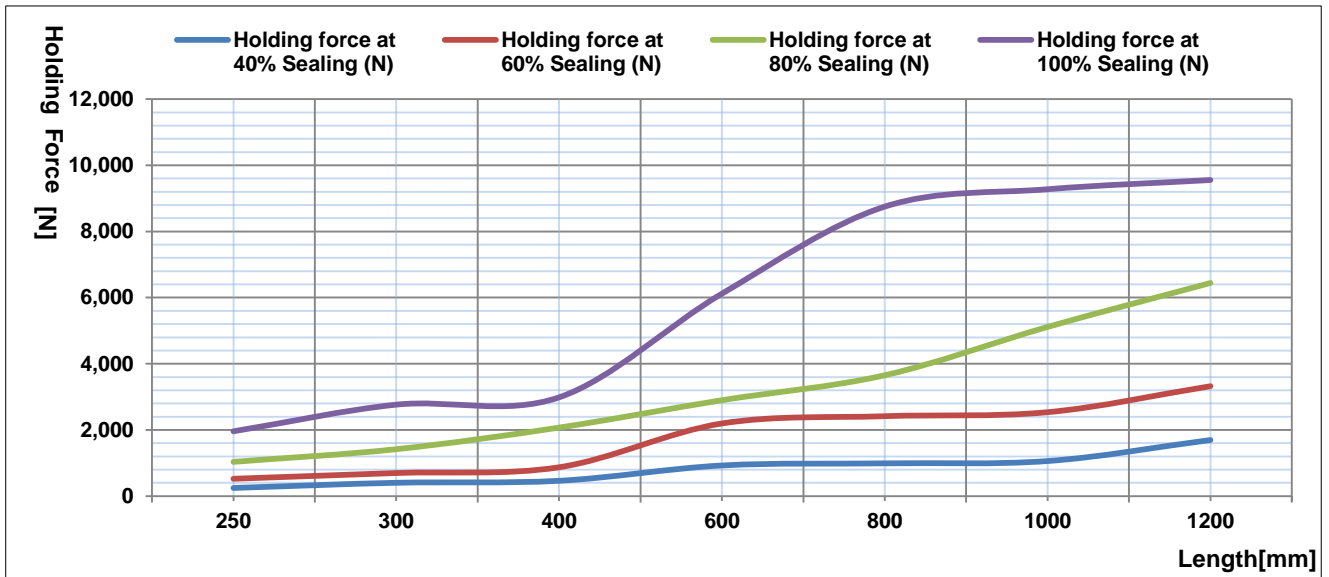

## G200 Series Weight (kg) according to Length (mm)

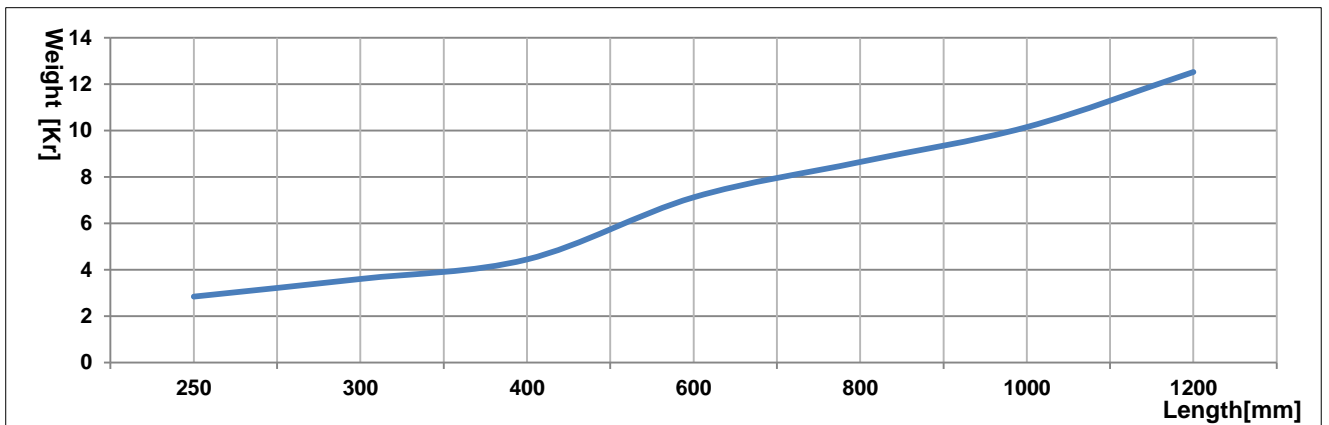

## G200 Series Holding Force(N) according to the Number of Cartridge (on each length)

※ Models G200X400 and under : 2~4 Cartridge is possible  
 Models G200X600 and over : 2~8 Cartridge is possible

### ► ES Type

250 / 300 / 400

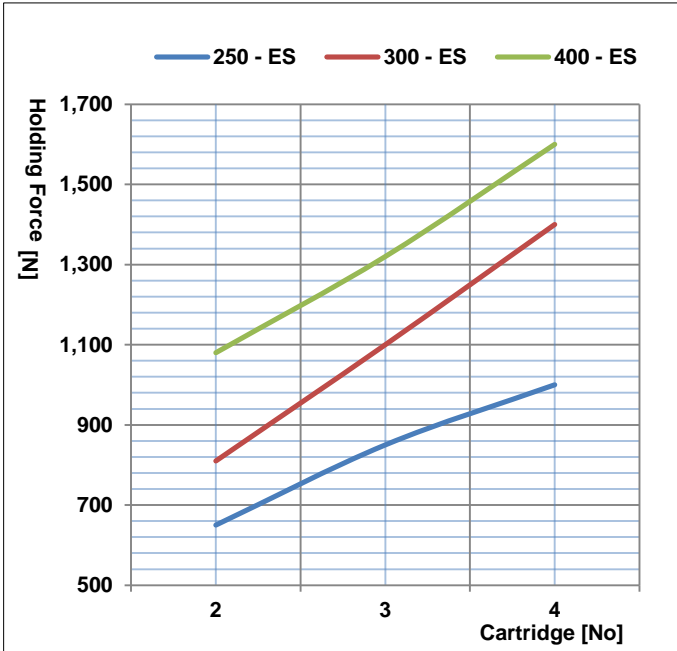

600 / 800 / 1000 / 1200

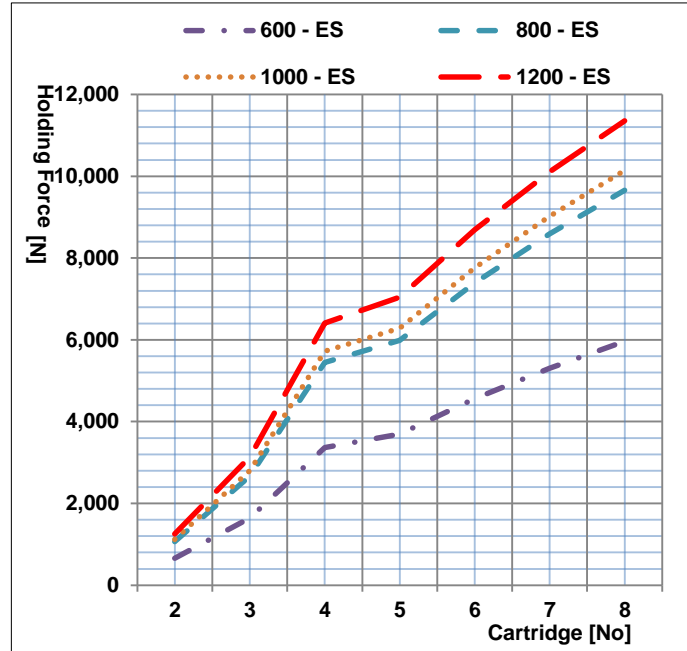

### ► AW Type

250 / 300 / 400

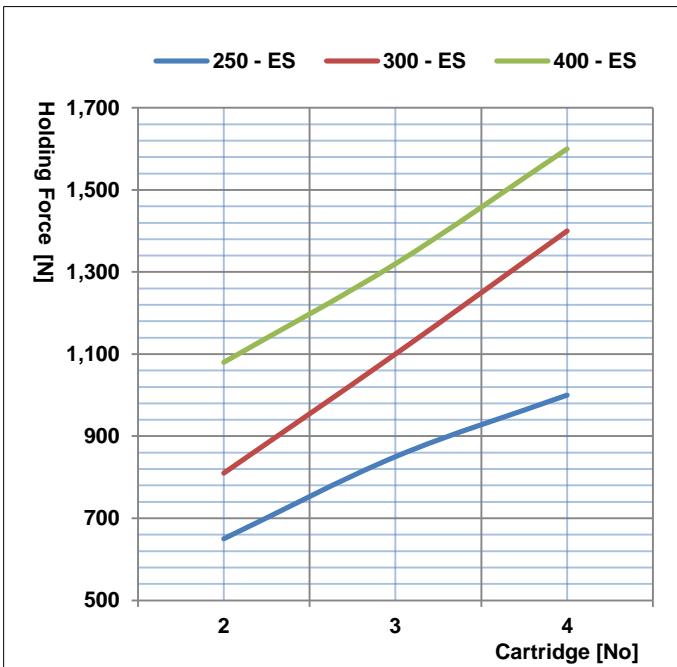

600 / 800 / 1000 / 1200

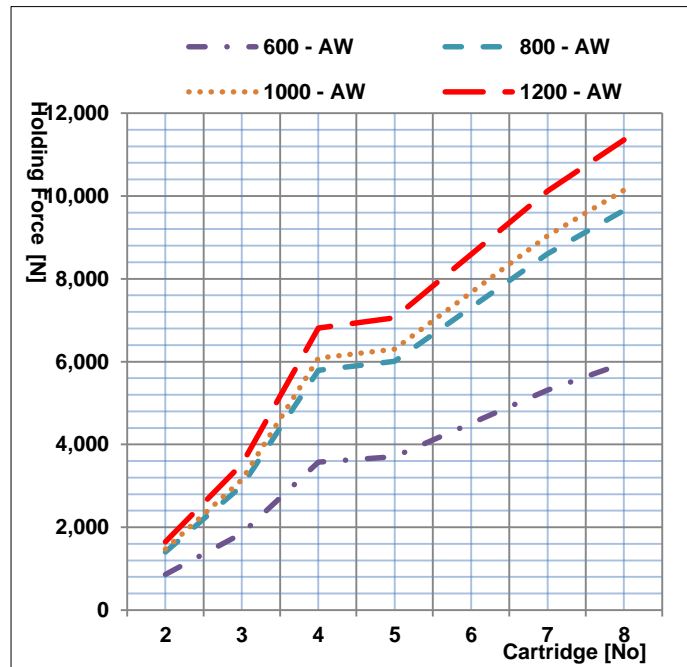

## Dimensions

### ▼ G 200 ... Series(220~400)

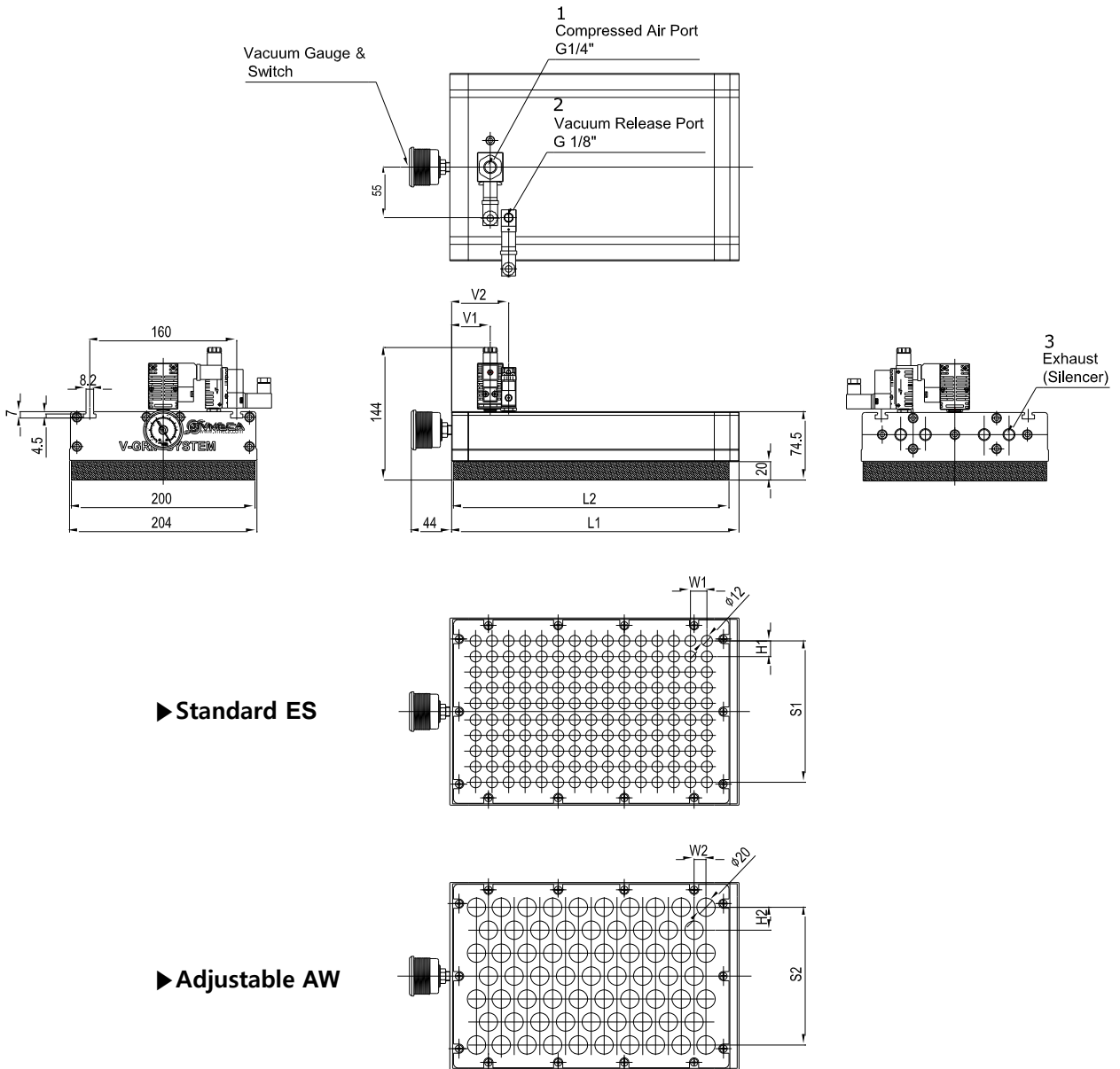

Measure Unit : mm

Model	Length	Sponge Pad Length	Standard Vacuum Port (Φ12)			Adjustable Vacuum Port (Φ20)			Air Control Valve		Release Valve			
	L1	L2	No.	W1	H1	S1	No.	W2	H2	S2	V1	Type	V2	Type
G 200 X 250...	265	220	120	18	17	154	45	14	25	150	61.7	VMS14	35	VMS18D
G 200 X 300...	315	300	150	18	17	154	67	13	25	150	44	VMS14	70	VMS18D
G 200 X 400...	415	400	120	25	22	154	72	20	22	148	44	VMS14	70	VMS18D



## Dimensions

### ▼ G 200 ... Series(600~1200)

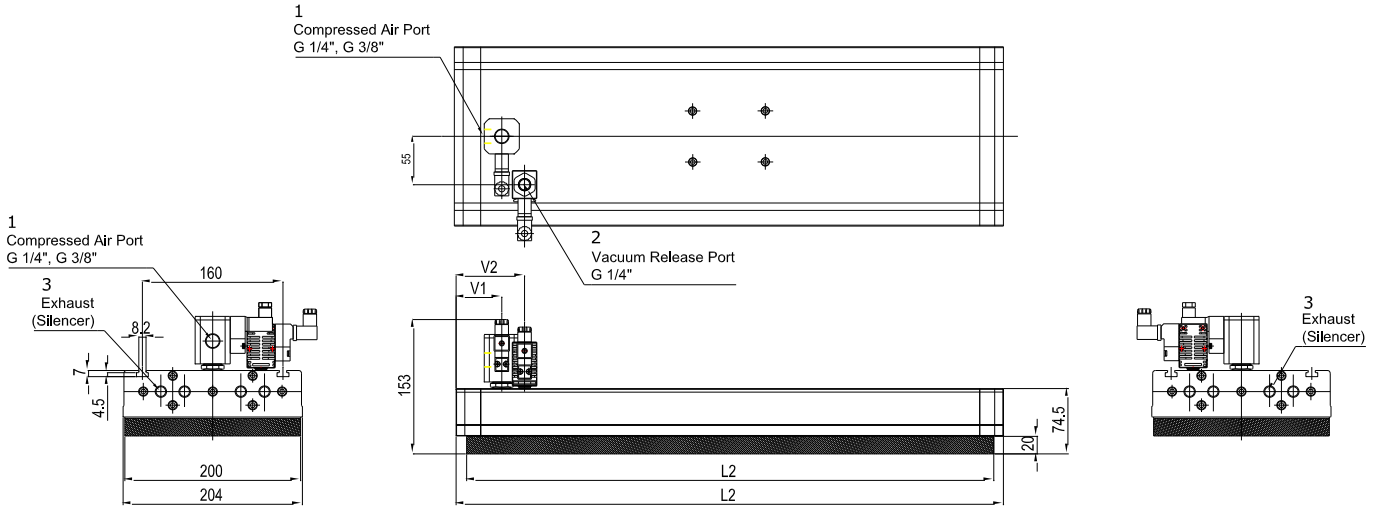

#### ► Standard ES

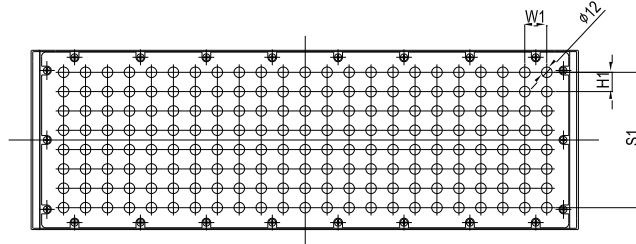

#### ► Adjustable AW

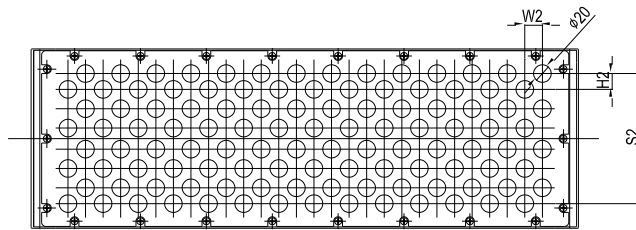

Measure Unit : mm

Model	Full Length	Sponge Pad Length	Standard Vacuum Port( $\Phi 12$ )				Adjustable Vacuum Port ( $\Phi 20$ )				Air control Valve		Release Valve	
	L1		L2	No	W1	H1	S1	No	W2	H2	S2	V1*	Type**	V2***
<b>G 200 X 600...</b>	622	600	184	25	22	154	112	20	22	148	51	VMS14 VMS38	77	VMS14
<b>G 200 X 800...</b>	822	800	248	25	22	154	152	20	22	148	51	VMS14 VMS38	77	VMS14
<b>G 200 X 1000...</b>	1022	1000	312	25	22	154	192	20	22	148	51	VMS14 VMS38	77	VMS14
<b>G 200 X 1200...</b>	1222	1200	376	25	22	154	232	20	22	148	51	VMS14 VMS38	77	VMS14

\* Cartridge 2~4 Model : 44mm  
Cartridge 5~8 Model : 56mm

\*\* Cartridge 2~6 Model : Use VMS14 Valve  
Cartridge 7~8 Model : Use VMS38 Valve

\*\*\* Cartridge 2~6 Model : 70mm  
Cartridge 7~8 Model : 77mm



## G 300 Series

Max. vacuum level	: - 75 kPa (-563 mmHg)
Max. flow rate	: 2,896 NI/min (101.4 scfm)
Supply air pressure	: 4 ~ 6bar, max 7bar (58~87psi, Max.101.5 psi)
Air consumption	: 832 NI/min (29.1 scfm)
Supply air type	: Dry compressed air
Working temperature	: - 20°C ~ 80°C (-4°F ~ 176°F)
Noise level	: 55 ~ 65 dBA



### Features

- ✓ Handles various products with different shapes, sizes and porous material
- ✓ Flexible sealing foam(EPDM) sponge pad to excellent grip.
- ✓ Adjustable check valve available
- ✓ Durable and light weight aluminum body frame
- ✓ Easy Installation and low maintenance

## Ordering Information

### G 300 X 300 - L4 - E S - A3 R3 DN - G

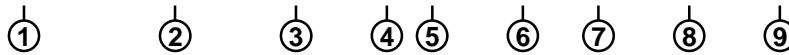

- ① **G Series (width)**
- **G 300** - 304mm
- ② **Length**
- **300** - 300mm
  - **400** - 400mm
  - **600** - 600mm
  - **800** - 800mm
  - **1000** - 1000mm
  - **1200** - 1200mm

- ⑦ **Release Valve**
- **R1** - N/C, AC110V
  - **R2** - N/C, AC220V
  - **R3** - N/C, DC24V

Valve's type according to the length (No②)  
 Under 600mm : VMS18D  
 Over 600mm : VMS14

- ⑧ **Solenoid Terminal**
- **DN** - DIN type without lead wire
  - **DL** - DIN type with lamp without lead wire
  - **CL** - Connector Type with lamp & 0.3 m lead wire

③ **Vacuum Cartridge Type**

	Feed Pressure MPa ( psi )	Max Vacuum Level -kPa ( -mmHg )	Max Vacuum flow NI/min ( scfm )
L2	0.6 (87)	75 (563)	724(-25.6)
L3	0.6 (87)	75 (563)	1,086(-38.4)
• L4	0.6 (87)	75 (563)	1,448(-51.1)
L5	0.6 (87)	75 (563)	1,810(-63.9)
L6	0.6 (87)	75 (563)	2,172(-76.7)
L7	0.6 (87)	75 (563)	2,534(-89.5)
L8	0.6 (87)	75 (563)	2,896(-102.3)

Cartridge's selection according to the length (No②) : 300 ~ 500mm: L2 ~ L4  
 600 ~ 1200mm: L2 ~ L8

⑨ **Vacuum Switch**

- **G** - Dial Gauge Attached (VTG-18)
- - Not attached
- **S2(P)** - Digital output 2 points, No analog supply  
M8-4Pin male connector (0.3m lead wire)
- **SG2(P)** - Digital output 2 points, No analog supply  
(Grommet type 4 core, 2m lead wire)
- **SG3(P)** - Digital output 2 points, Analog Supply  
(Grommet type 5 core, 2m lead wire)

※Mark : ① S..(P)  
 L Output type : PNP open collector  
 ② VC M8-4-2 : M8-4 pin female connector  
 Option for 'S2' or 'S2P'

④ **Check Valve**

- **E** - Standard
- **A** - Adjustable

⑤ **Port Spacing**

- **S** - Narrow
- **W** - Wide

⑥ **Air Control Valve**

- **A1** - N/C, AC110V
- **A2** - N/C, AC220V
- **A3** - N/C, DC24V
- **D1** - Double Solenoid AC110V
- **D2** - Double Solenoid AC220V
- **D3** - Double Solenoid DC24V

A.. : No ③ Restrict according to the vacuum cartridge  
 L2 ~ L5: G1/4" : VMS14 Valve  
 L6 ~ L8: G3/8" : VMS38 Valve  
 D.. : G3/8" Double Solenoid Valve

Double Solenoid Valve is only possible DN, DL type in the No.8

## G300 Series Characteristics

Model	Air inlet Pressure Mpa (psi)	Air consumption N/m (scfm)	Max. Vacuum Flows N/m (scfm)	Max. Vacuum level -kPa (-mmHg)
G 300 X 300 L4...	0.6 (87)	416 (14.6)	1,448 (51.1)	75 (563)
G 300 X 400 L4...	0.6 (87)	416 (14.6)	1,448 (51.1)	75 (563)
G 300 X 600 L8...	0.6 (87)	832 (29.1)	2,896 (102.3)	75 (563)
G 300 X 800 L8...	0.6 (87)	832 (29.1)	2,896 (102.3)	75 (563)
G 300 X 1000 L8...	0.6 (87)	832 (29.1)	2,896 (102.3)	75 (563)
G 300 X 1200 L8...	0.6 (87)	832 (29.1)	2,896 (102.3)	75 (563)

## G300 Series Holding Force (N) % according to Length (mm)

### Standard (ES TYPE)

Model	Holding force at 40% Sealing (N)	Holding force at 60% Sealing (N)	Holding force at 80% Sealing (N)	Holding force at 100% Sealing (N)	Weight (Kg)*
G 300 X 300 L4 ES...	409.7	867.1	1743.4	4193.4	3.8
G 300 X 400 L4 ES...	654.1	983.5	2004.9	4738.6	6.1
G 300 X 600 L8 ES...	1107.9	2591.1	3207.9	8197.7	9.6
G 300 X 800 L8 ES...	1272.7	2863.0	4587.3	13239.3	12.2
G 300 X 1000 L8 ES...	1397.9	3303.1	5000.1	13901.3	14.8
G 300 X 1200 L8 ES...	1488.2	4677.4	7250.2	15986.5	17.5

### Adjustable(AW TYPE)

Model	Holding force at 40% Sealing (N)	Holding force at 60% Sealing (N)	Holding force at 80% Sealing (N)	Holding force at 100% Sealing (N)	Weight (Kg)*
G 300 X 300 L4 AW...	409.7	585.3	1545.7	4444.8	3.6
G 300 X 400 L4 AW...	471.2	731.6	2256.7	4800.4	5.4
G 300 X 600 L8 AW...	942.3	1843.7	3159.4	9840.8	9.1
G 300 X 800 L8 AW...	1008.3	2028.1	3980.9	14072.3	11.2
G 300 X 1000 L8 AW...	1078.9	2129.5	5573.2	14916.6	13.5
G 300 X 1200 L8 AW...	1726.2	2789.6	7022.3	15364.1	16.8

\*\* Note : Actual Figure may be different according to the surface and porosity of product .  
 \* Weight of Flange mount not included.



## G300 Series Holding Force(N) according to the length(mm)

### ► ES Type

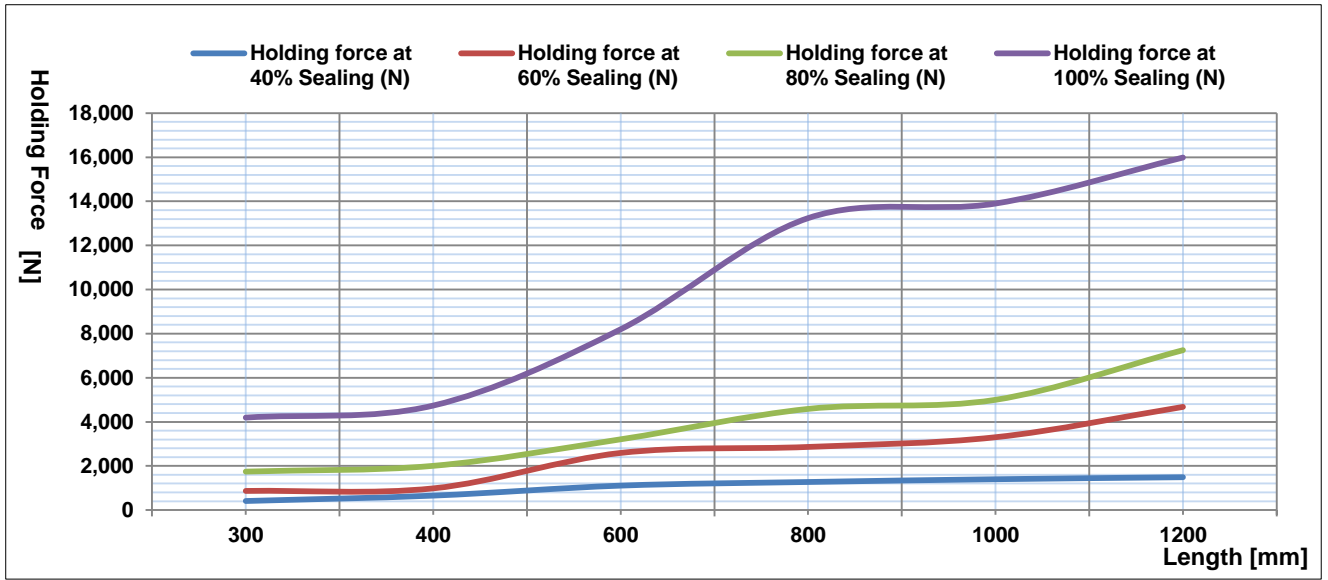

### ► AW Type

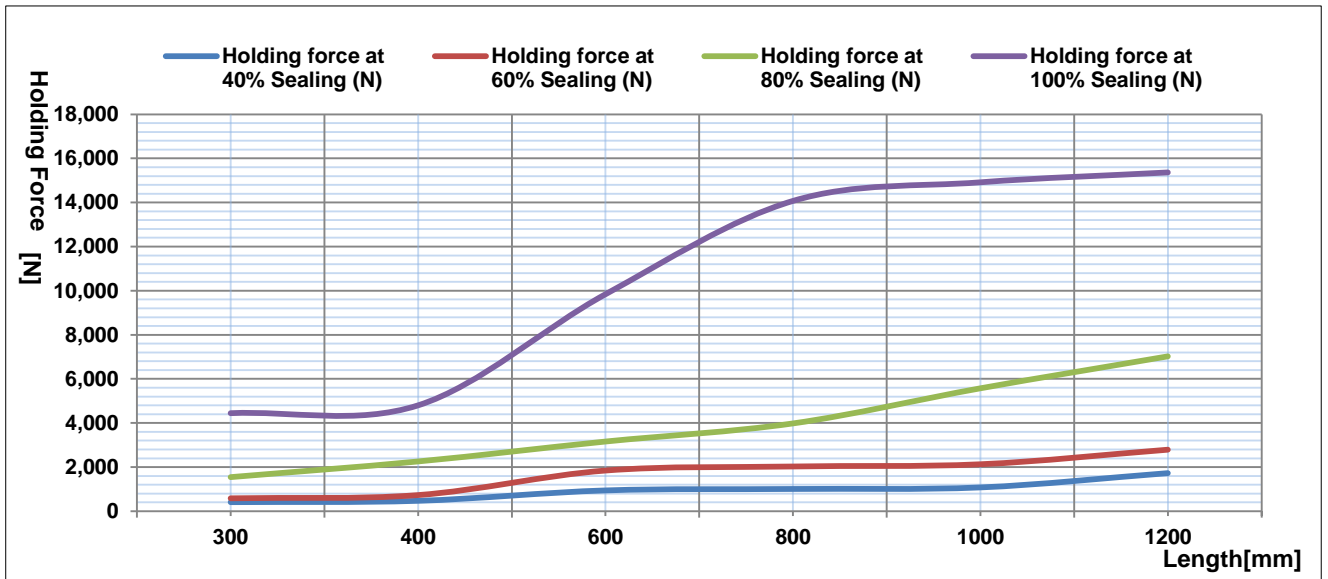

## G300 Series Weight (kg) according to Length (mm)

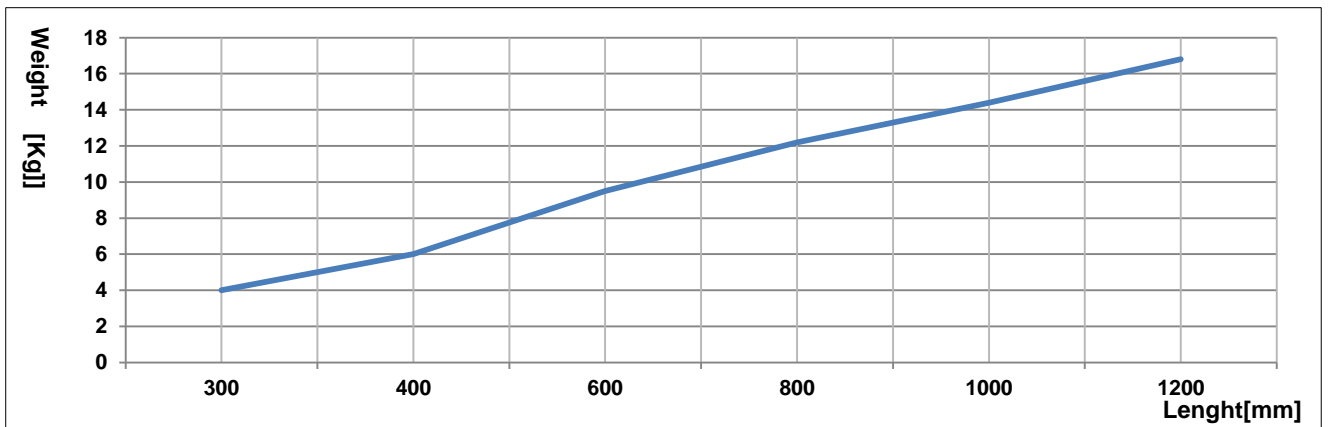



## G300 Series Holding Force (N) according to the Number of Cartridge

※ Models G300X400 and under : 2~4 Cartridge is possible  
 Models G300X600 and over : 2~8 Cartridge is possible

### ► ES Type

300 / 400

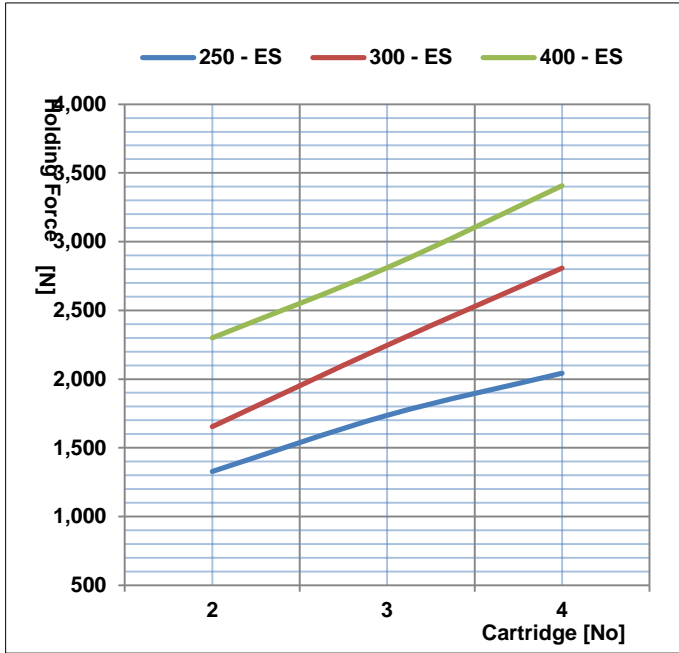

600 / 800 / 1000 / 1200

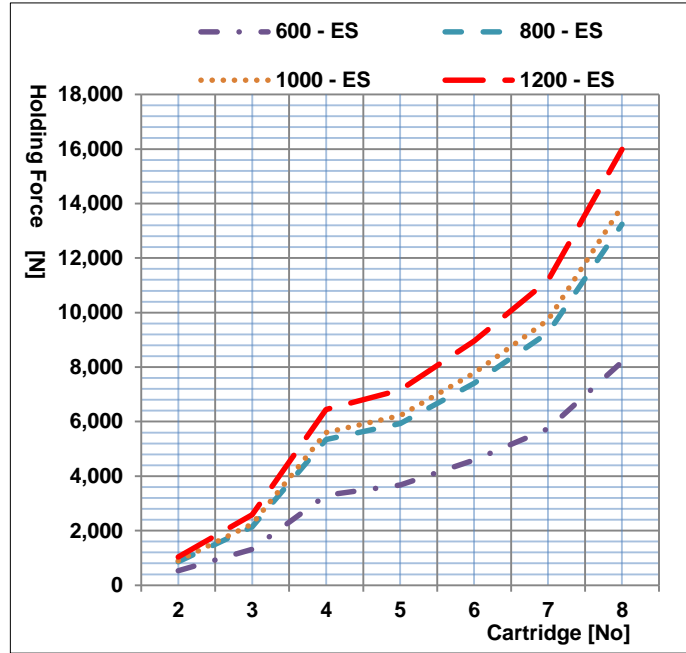

### ► AW Type

300 / 400

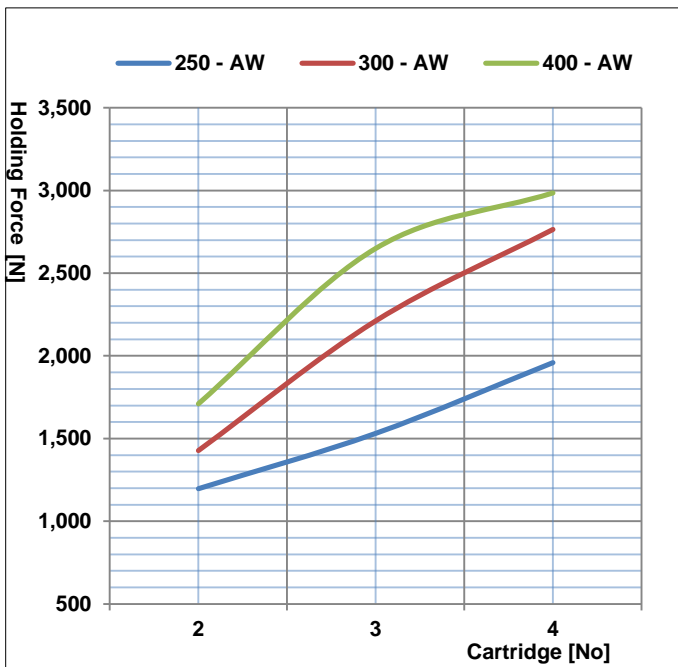

600 / 800 / 1000 / 1200

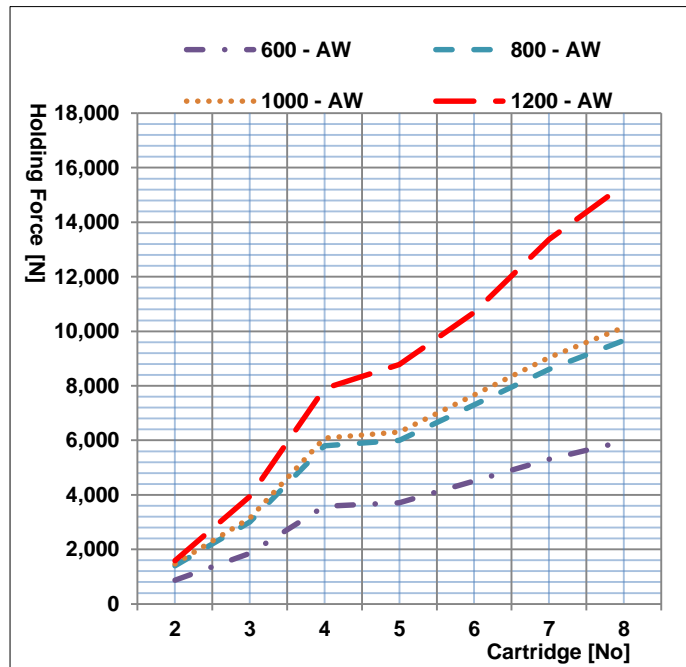

## Dimensions

### ▼ G 300 ... Series(300~400)

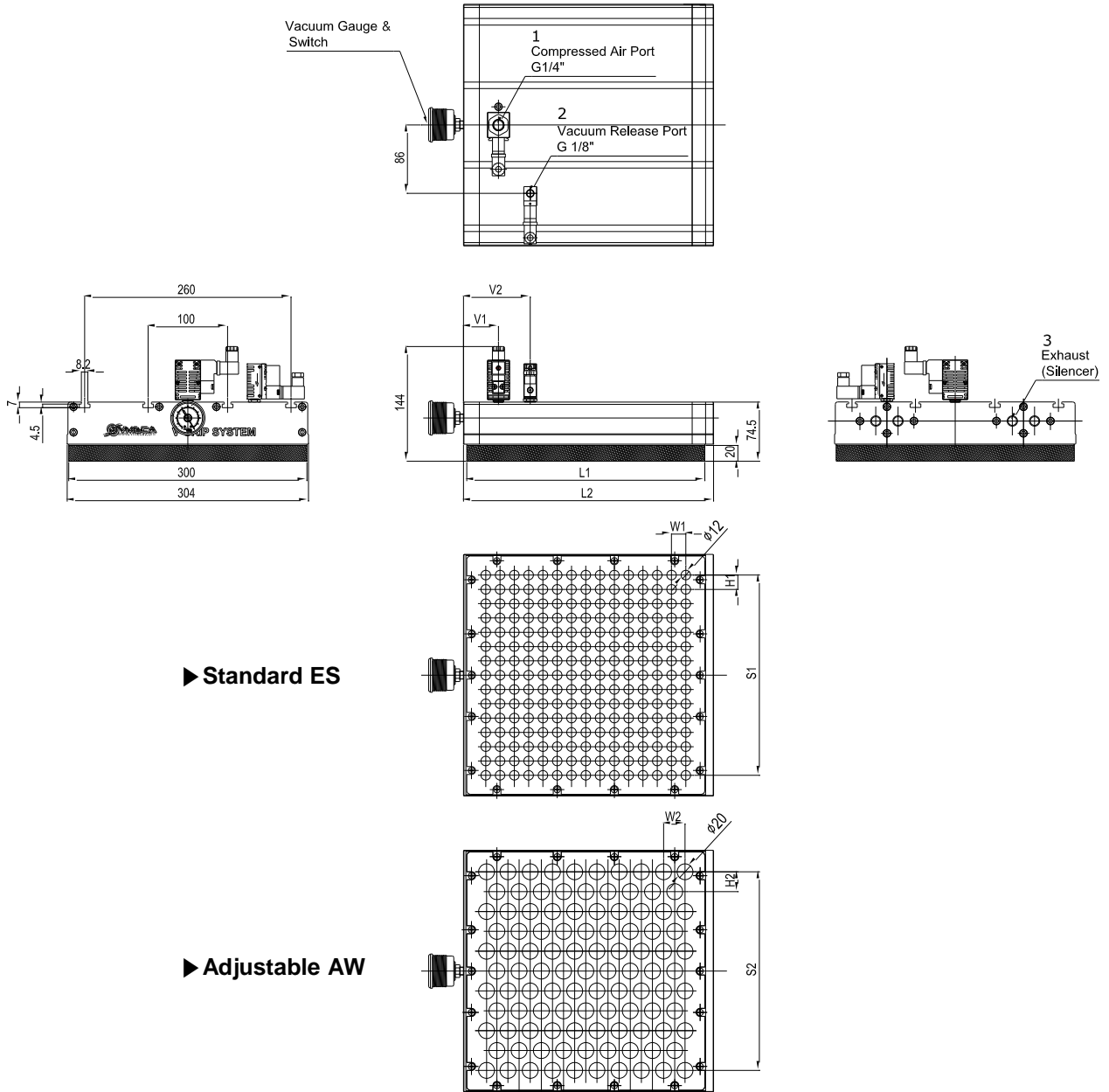

► Standard ES

► Adjustable AW

Measure Unit : mm

Model	Full Length	Sponge Pad Length	Standard Vacuum Port(Φ12)			Adjustable Vacuum Port(Φ20)				Air Control Valve		Release Valve		
	L1		L2	No.	W1	H1	S1	No.	W2	H2	S2	V1	Type	V2
G 300 X 300...	315	300	225	18	18	252	105	14	25	250	44	VMS14	84	VMS18D
G 300 X 400...	415	400	180	25	22	242	108	20	22	242	44	VMS14	84	VMS18D



## Dimensions

### ▼ G 300 ... Series(600~1200)

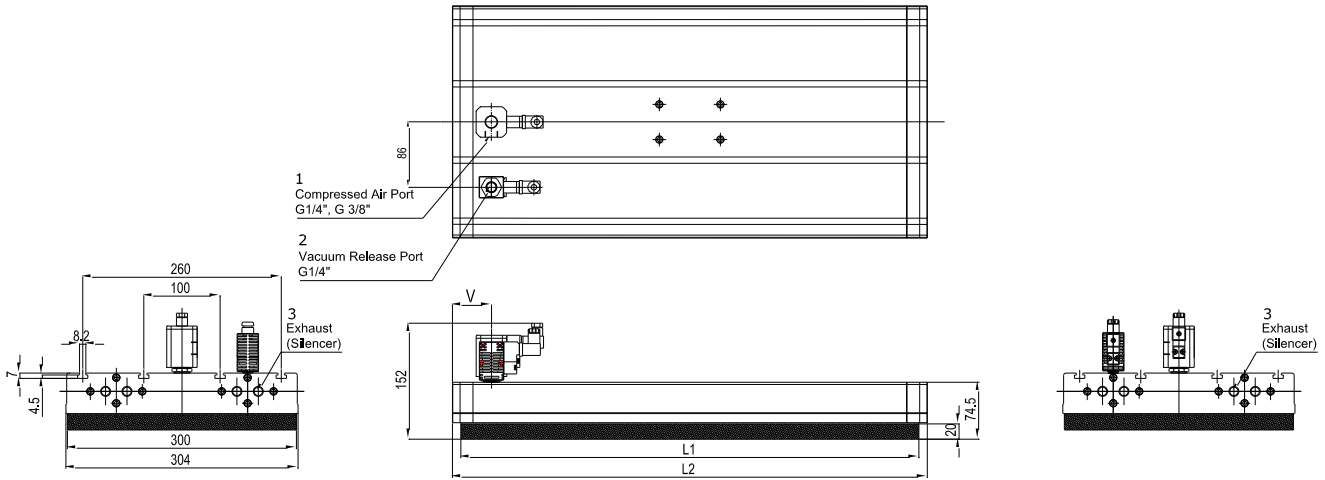

#### ► Standard ES

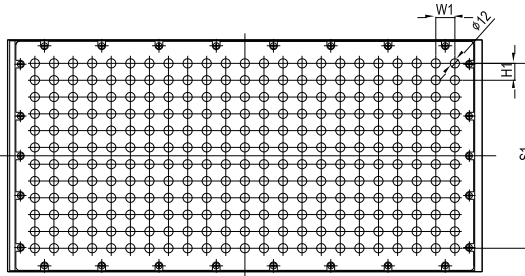

#### ► Adjustable AW

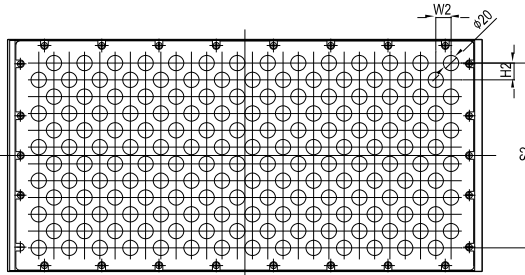

Measure Unit : mm

Model	Full Length	Sponge Pad Length	Standard Vacuum Port(Φ12)			Adjustable Vacuum port (Φ20)				Air Control Valve		Release Valve		
	L1	L2	No.	W1	H1	S1	No.	W2	H2	S2	V1*	Type**	V2	Type
<b>G 300 X 600...</b>	622	600	276	25	22	242	168	20	22	242	51	VMS14 VMS38	91	VMS14
<b>G 300 X 800...</b>	822	800	372	25	22	242	228	20	22	242	51	VMS14 VMS38	91	VMS14
<b>G 300 X 1000...</b>	1022	1000	468	25	22	242	288	20	22	242	51	VMS14 VMS38	91	VMS14
<b>G 300 X 1200...</b>	1222	1200	564	25	22	242	348	20	22	242	51	VMS14 VMS38	91	VMS14

\* Cartridge 2~4 :70mm  
Cartridge 5~8 : 77mm

\*\* Cartridge 2~6 Model : Use VMS14 Valve  
Cartridge 7~8 Model : Use VMS38 Valve

## GF 80 Series

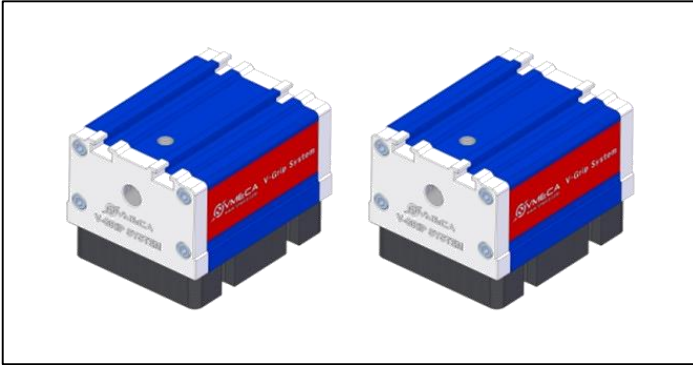

### Features

- ✓ Available with easy connection on various **VMECA** vacuum pump
- ✓ Handles various products with different shapes, sizes and porous material
- ✓ Flexible sealing foam(EPDM) sponge pad grips excellently
- ✓ Adjustable check valve available
- ✓ Durable and light weight aluminum extrusion body frame
- ✓ Easy Installation and low maintenance

## Ordering Information

### GF 80 X 250 - E S - R3 DN - G

①      ②      ③ ④      ⑤      ⑥      ⑦

#### ① G Series (width)

- **GF 80** - 84mm

#### ② Length

- 100 - 100mm
- 150 - 150mm
- 200 - 200mm
- 220 - 220mm
- **250** - 250mm
- 300 - 300mm

#### ③ Check Valve

- **E** - Standard
- A - Adjustable

#### ④ Port Spacing

- **S** - Narrow
- W - Wide

#### ⑤ Release Valve

- R1 - G1/8", N/C, AC110V
  - R2 - G1/8", N/C, AC220V
  - **R3** - G1/8", N/C, DC24V
- ※ Remark : VMS18D Valve only

#### ⑥ Solenoid Terminal

- **DN** - DIN type without lead wire
- DL - DIN type with lamp without lead wire
- Connector Type with
- CL** - lamp & 0.3 m lead wire

#### ⑦ Vacuum Switch

- **G** - Dial Gauge Attached (VTG-18)
- - Not attached
- S2(P)** - Digital output 2 points, No analog supply  
M8-4Pin male connector (0.3m lead wire)
- SG2(P)** - Digital output 2 points, No analog supply  
(Grommet type 4 core, 2m lead wire)
- SG3(P)** - Digital output 2 points, Analog Supply  
(Grommet type 5 core, 2m lead wire)

※Mark : ① S\_(P)  
L Output type : PNP open collector  
②VC M8-4-2 : M8-4 pin female connector  
Option for 'S2' or 'S2P'



## Dimensions

### ▼ GF 80 ... Series

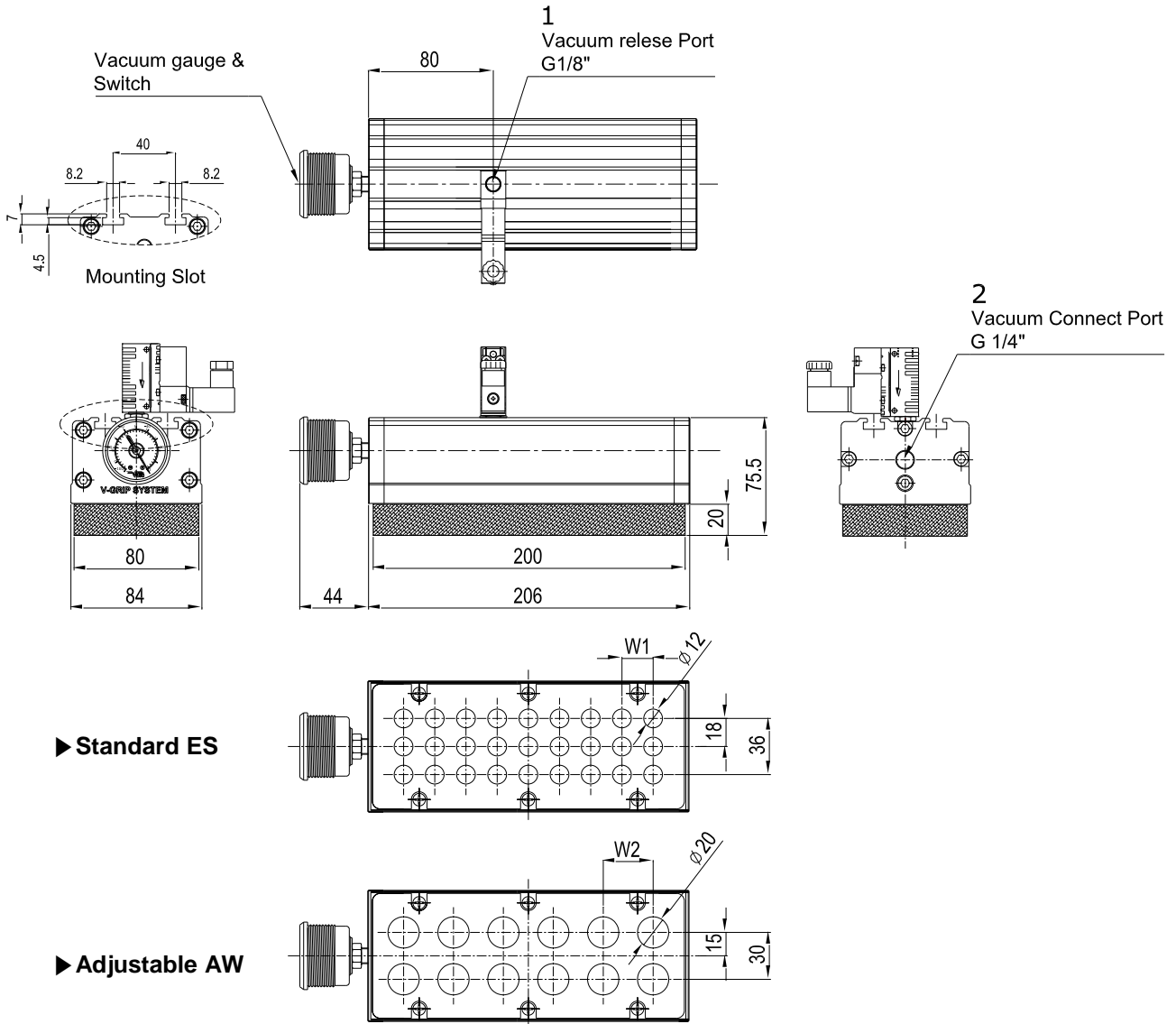

Measure Unit : mm

Model	Full Length	Sponge Pad Length	Standard Vacuum Port(Φ12)		Adjustable Vacuum port (Φ20)		Release Valve	
	L1	L2	No.	W1	No.	W2	V1	Type
GF 80 X 100...	106	100	12	20	6	30	20	VMS18D
GF 80 X 150...	160	150	21	20	10	30	20	VMS18D
GF 80 X 200...	206	200	27	20	12	34	20	VMS18D
GF 80 X 220...	226	220	30	20	14	30	83	VMS18D
GF 80 X 250...	256	250	36	20	16	30	34	VMS18D
GF 80 X 300...	306	300	48	18	20	30	80	VMS18D



## GF 130 Series

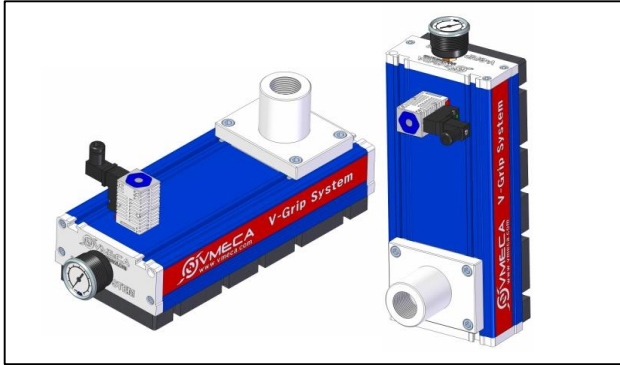

### Features

- ✓ Available with easy connection on various **VMECA** vacuum pump
- ✓ Handles various products with different shapes, sizes and porous material
- ✓ Flexible sealing foam(EPDM) sponge pad grips excellently
- ✓ Adjustable check valve available
- ✓ Durable and light weight aluminum extrusion body frame
- ✓ Easy Installation and low maintenance

## Ordering Information

### GF 130 X 300 - E S - R3 DN - G



#### ① Gripper Series (Width)

- **GF 130** - 134mm

#### ② Length

- 220 - 220mm
- 300 - 300mm
- 400 - 400mm
- 600 - 600mm
- 800 - 800mm
- 1000 - 1000mm
- 1200 - 1200mm

#### ③ Check Valve

- **E** - Standard
- **A** - Adjustable

#### ④ Port Spacing

- **S** - Narrow
- **W** - Wide

#### ⑤ Release Valve

- **R1** - N/C, AC110V
- **R2** - N/C, AC220V
- **R3** - N/C, DC24V

Valve's selection according to the No. ② Length  
 Under 600mm : VMS18D  
 Over 600mm : VMS14

#### ⑥ Solenoid Terminal

- **DN** - DIN type without lead wire
- **DL** - DIN type with lamp without lead wire
- **CL** - Connector Type with lamp & 0.3 m lead wire

#### ⑦ Vacuum Switch

- **G** - Dial Gauge Attached (VTG-18)
- - - Not attached
- **S2(P)** - Digital output 2 points, No analog supply M8-4Pin male connector (0.3m lead wire)
- **SG2(P)** - Digital output 2 points, No analog supply (Grommet type 4 core, 2m lead wire)
- **SG3(P)** - Digital output 2 points, Analog Supply (Grommet type 5 core, 2m lead wire)

※Mark : ① S..(P)

L Output type : PNP open collector

② VC M8-4-2 : M8-4 pin female connector  
 Option for 'S2' or 'S2P'



## Dimensions

### ▼ GF 130 ... Series

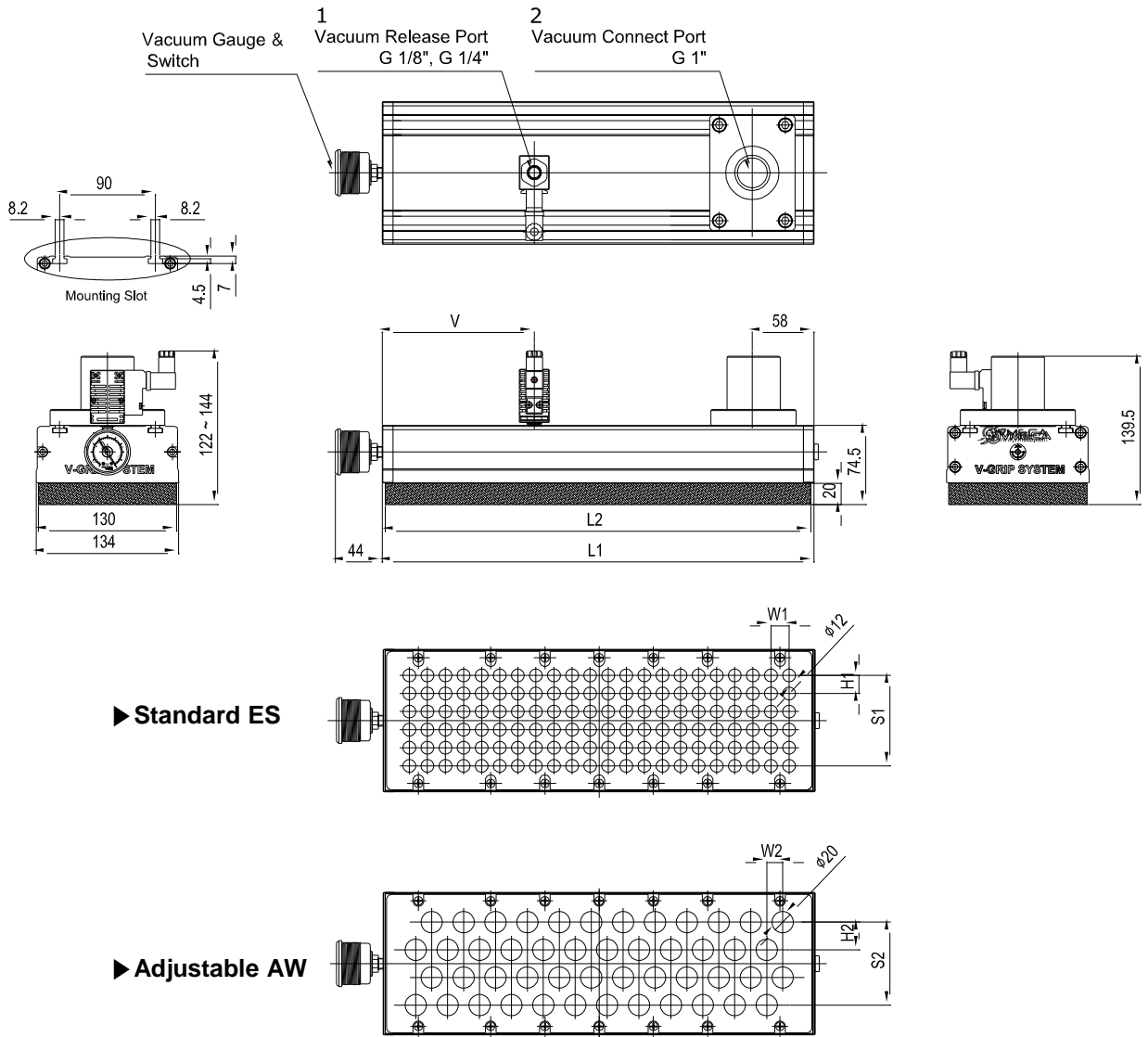

Measure Unit : mm

Model	Full Length	Sponge Pad Length	Standard Vacuum Port (Φ12)				Adjustable Vacuum port (Φ20)				Release Valve	
	L1		L2	No.	W1	H1	S1	No.	W2	H2	S2	V
GF 130 X 220...	234	220	66	17	17	85	26	14	24	72	33	VMS18D
GF 130 X 300...	314	300	96	17	17	85	38	14	25	72	33	VMS18D
GF 130 X 400...	414	400	132	17	17	85	48	14	26	72	133	VMS18D
GF 130 X 600...	614	600	156	22	18	90	76	15	26	78	263	VMS14
GF 130 X 800...	814	800	210	22	18	90	104	15	26	78	263	VMS14
GF130 X 1000...	1028	1000	348	17	17	85	133	18.5	21	79	263	VMS14
GF 130 X 1200...	1214	1200	324	22	18	90	156	15	26	78	263	VMS14



## GF 200 Series

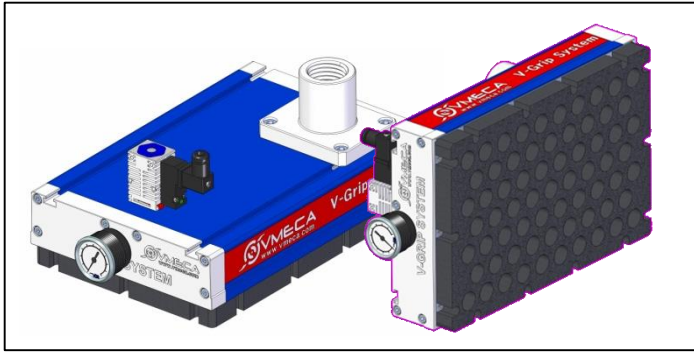

### Features

- ✓ Available with easy connection on various **VMECA** vacuum pump
- ✓ Handles various products with different shapes, sizes and porous material
- ✓ Flexible sealing foam(EPDM) sponge pad grips excellently
- ✓ Adjustable check valve available
- ✓ Durable and light weight aluminum extrusion body frame
- ✓ Easy Installation and low maintenance

## Ordering Information

### GF 200 X 300 - E S - R3 DN - G



#### ① G Series (width)

- **GF 200** - 204mm

#### ② Length

- 250 - 250mm
- **300** - 300mm
- 400 - 400mm
- 600 - 600mm
- 800 - 800mm
- 1000 - 1000mm
- 1200 - 1200mm

#### ③ Check Valve

- **E** - Standard
- A - Adjustable

#### ④ Port Spacing

- **S** - Narrow
- W - Wide

#### ⑤ Release Valve

R1 - N/C, AC110V

R2 - N/C, AC220V

- **R3** - N/C, DC24V

Valve's selection according to the

No. ② Length

Under 600mm : VMS18D

Over 600mm : VMS14

#### ⑥ Solenoid Terminal

- **DN** - DIN type without lead wire
- DL - DIN type with lamp without lead wire
- Connector Type with
- CL - lamp & 0.3 m lead wire

#### ⑦ Vacuum Switch

- **G** - Dial Gauge Attached (VTG-18)
- - Not attached
- **S2(P)** - Digital output 2 points, No analog supply M8-4Pin male connector (0.3m lead wire)
- **SG2(P)** - Digital output 2 points, No analog supply (Grommet type 4 core, 2m lead wire)
- **SG3(P)** - Digital output 2 points, Analog Supply (Grommet type 5 core, 2m lead wire)

※Mark : ① S..(P)

↳ Output type : PNP open collector

② VC M8-4-2 : M8-4 pin female connector

Option for 'S2' or 'S2P'





## Dimensions

### ▼ GF 200 ... Series

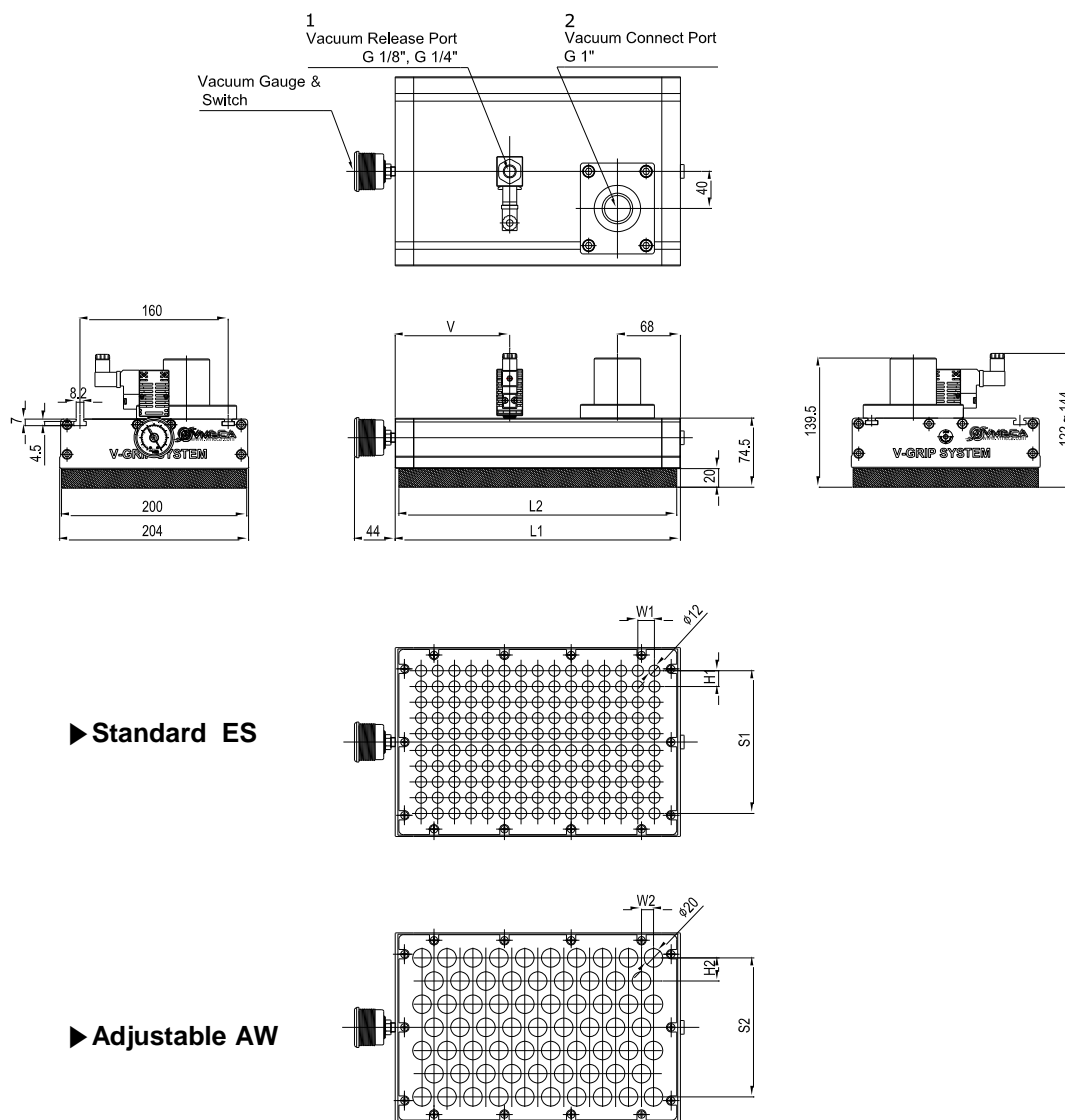

Measure Unit : mm

Model	Full Length	Sponge Pad Length	Standard Vacuum Port (Φ12)			Adjustable Vacuum Port (Φ20)			Release Valve			
	L1	L2	No.	W1	H1	S1	No.	W2	H2	S2	V	Type
GF 200 X 250...	253	220	110	18	17	154	53	14	25	150	61.7	VMS18D
GF 200 X 300...	215	300	150	18	17	154	72	13	25	150	44	VMS18D
GF 200 X 400...	415	400	120	25	22	154	112	20	24	148	44	VMS18D
GF 200 X 600...	615	600	176	25	22	154	76	20	24	148	44	VMS14
GF 200 X 800...	815	800	248	25	22	154	104	20	24	148	44	VMS14
GF200 X 1000...	1015	1000	312	25	22	154	133	20	24	148	44	VMS14
GF 200 X 1200...	1215	1200	376	25	22	154	156	20	24	148	44	VMS14



## GF 300 Series

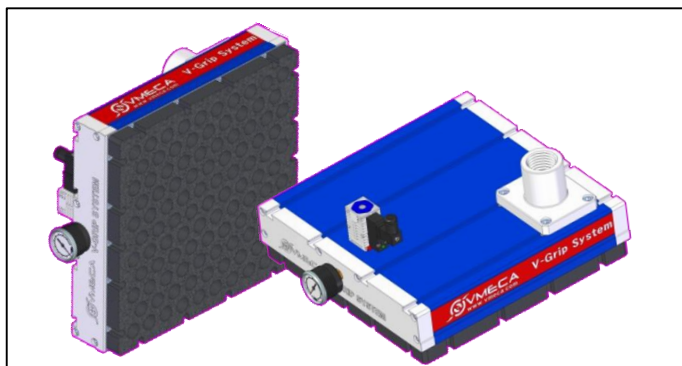

### Features

- ✓ Available with easy connection on various **VMECA** vacuum pump
- ✓ Handles various products with different shapes, sizes and porous material
- ✓ Flexible sealing foam(EPDM) sponge pad grips excellently
- ✓ Adjustable check valve available
- ✓ Durable and light weight aluminum extrusion body frame
- ✓ Easy Installation and low maintenance

## Ordering Information

### GF 300 X 300 - E S - R3 DN - G

①                      ②                      ③ ④                      ⑤                      ⑥                      ⑦

#### ① G Series (width)

- **GF 300** - 304mm

#### ② Length

- **300** - 300mm
- 400** - 400mm
- 600** - 600mm
- 800** - 800mm
- 1000** - 1000mm
- 1200** - 1200mm

#### ③ Check Valve

- **E** - Standard
- A** - Adjustable

#### ④ Port Spacing

- **E** - Standard
- A** - Adjustable

#### ⑤ Release Valve

- R1** - N/C, AC110V
- R2** - N/C, AC220V
- **R3** - N/C, DC24V

Valve's selection according to the No. ② Length  
 Under 600mm : VMS18D  
 Over 600mm : VMS14

#### ⑥ Solenoid Terminal

- **DN** - DIN type without lead wire
- DL** - DIN type with lamp without lead wire
- Connector Type with**
- CL** - lamp & 0.3 m lead wire

#### ⑦ Vacuum Switch

- **G** - Dial Gauge Attached (VTG-18)
- - Not attached
- S2(P)** - Digital output 2 points, No analog supply  
M8-4Pin male connector (0.3m lead wire)
- SG2(P)** - Digital output 2 points, No analog supply  
(Grommet type 4 core, 2m lead wire)
- SG3(P)** - Digital output 2 points, Analog Supply  
(Grommet type 5 core, 2m lead wire)

※Mark : ① S..(P)

L Output type : PNP open collector

② VC M8-4-2 : M8-4 pin female connector  
 Option for 'S2' or 'S2P'



## Dimensions

### ▼ GF 300 ... Series

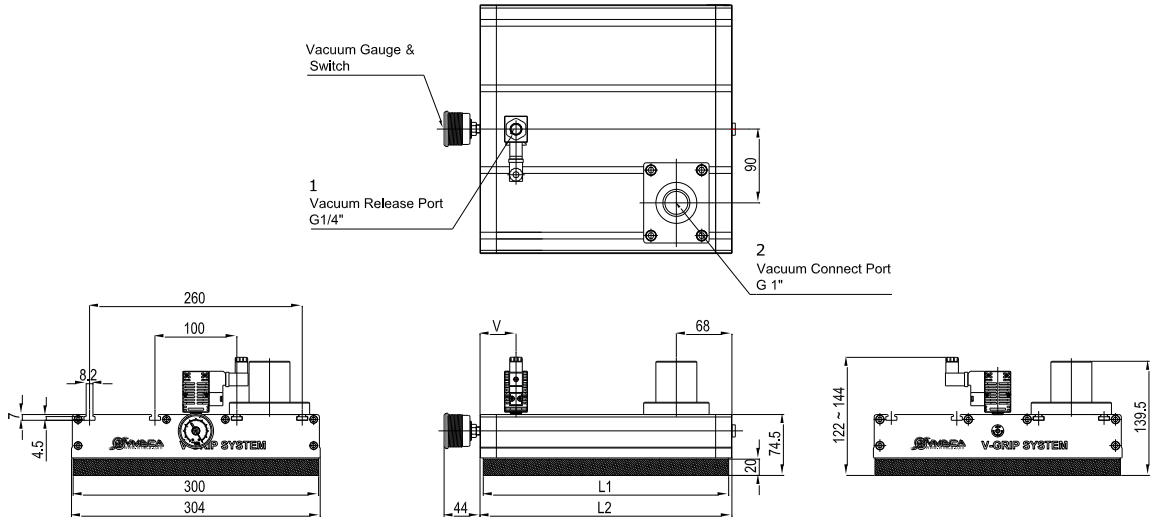

#### ► Standard ES

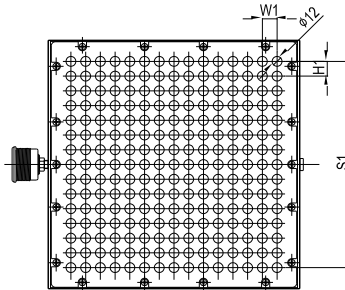

#### ► Adjustable AW

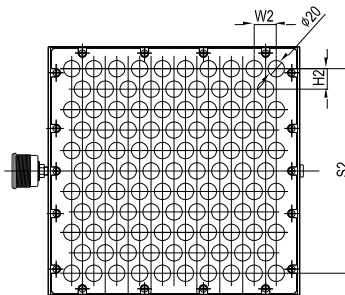

Measure Unit : mm

Model	Full Length	Sponge Pad Length	Standard Vacuum Port ( $\Phi 12$ )			Adjustable Vacuum port ( $\Phi 20$ )			Release Valve			
	L1	L2	No.	W1	H1	S1	No.	W2	H2	S2	V	Type
GF 300 X 300...	308	300	225	18	18	252	105	14	25	250	61.7	VMS18D
GF 300 X 400...	408	400	180	25	22	242	108	20	25	242	44	VMS18D
GF 200 X 600...	608	600	176	25	22	154	76	20	24	148	44	VMS14
GF 200 X 800...	808	800	248	25	22	154	104	20	24	148	44	VMS14
GF200 X 1000...	1008	1000	312	25	22	154	133	20	24	148	44	VMS14
GF 200 X 1200...	1208	1200	376	25	22	154	156	20	24	148	44	VMS14