



# Technical Data Sheet

## Type 75HD



3/2-Way solenoid valve  
 In rest position P is normally closed towards A and A is normally open towards R.  
 When energized the solenoid lifts the sealing element from the valve seat and opens P towards A and closes A towards R.  
 The valve works without pressure difference. The valve resets by spring power.

■ **Solenoid valve for neutral, gaseous and liquid media**

Type 75HD

### TECHNICAL SPECIFICATIONS

Type of control:	direct acting, no pressure difference is required
Design:	Piston design
Connection:	Threaded G <sup>1</sup> / <sub>4</sub> , DIN ISO 228 (BSP) Other sizes and connections like NPT on request
Installation:	Actuator only in upright position
Pressure:	0-300 bar (see table page 2)
Medium:	Clean, neutral, gaseous and liquid medium
Viscosity:	22 mm <sup>2</sup> /s
Temperature range:	Medium: -30 °C up to +80 °C Ambient: -30 °C up to +50 °C In consideration of the restrictions described on page 3
Body material:	Brass 2.0401 Stainless steel 1.4301 (AISI 304)
Metallic inner parts:	Brass and Stainless steel
Sealing:	PTFE, Optional: PEEK
Supply voltage:	AC~ 24V, 110V, 230V DC= 12V, 24V, 110V Other supply voltages on request
Voltage tolerance:	-10% / +10%
Power consumption:	.802 = 24 Watt      .808 = 24 Watt .322 = 30 Watt .242 = 46 Watt      .248 = 30 Watt
Protection class:	IP65 according to DIN EN 60529
Duty factor:	100% ED-VDE 0580
Connection type:	Plug / Terminal box
Ex-proof:	Ex e mb II T4 Further Ex-proof on request.

### VALVE FEATURES

- For high pressure applications up to 300 bar
- No pressure difference is required
- High life time
- Simple compact valve design
- Reliable and sturdy sealing elements
- Long-term availability of spare parts
- High-quality materials
- NO (non energized open) on request

### FUNCTION

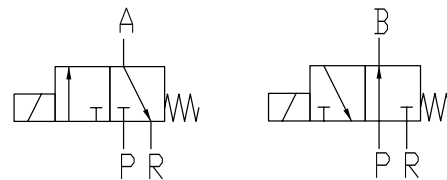

### CERTIFICATES



In special design also available for temperatures **up to +180 °C**.  
 Specifications and drawings on request.

### ORDERING SYSTEM

		Coil system	
.	75	40	/ 10 04 / . 24 2
<b>Connection</b>		<b>Body</b>	
40	G <sup>1</sup> / <sub>4</sub> , DN1,0	10	Brass 2.0401
41	G <sup>1</sup> / <sub>4</sub> , DN1,5	06	Stainless steel 1.4301
42	G <sup>1</sup> / <sub>4</sub> , DN2,0	<b>Seal</b>	
43	G <sup>1</sup> / <sub>4</sub> , DN2,5	04	PTFE
44	G <sup>1</sup> / <sub>4</sub> , DN3,0	15	PEEK
45	G <sup>1</sup> / <sub>4</sub> , DN4,0	2 Standard IP65	
46	G <sup>1</sup> / <sub>4</sub> , DN5,0	8 explosion proof acc. to Directive 94/9/EG (ATEX)	

# TECHNICAL FEATURES

G	Seat $\varnothing$ mm	Kv-value m <sup>3</sup> /h	Standard type	max. pressure				
				.802	.322	.242*	ATEX	
1/4	1,0	0,06	.7540/..04/...	0-100	0-160	0-300	0-100	0-300
1/4	1,5	0,09	.7541/..04/...	0-75	0-130	0-280	0-75	0-210
1/4	2,0	0,13	.7542/..04/...	0-45	0-100	0-250	0-45	0-180
1/4	2,5	0,16	.7543/..04/...	0-28	0-75	0-200	0-28	0-160
1/4	3,0	0,20	.7544/..04/...	0-20	0-60	0-150	0-20	0-90
1/4	4,0	0,35	.7545/..04/...	0-16	0-20	0-85	0-16	0-60
1/4	5,0	0,50	.7546/..04/...	0-16	0-20	0-55	0-16	0-38

The flow rate mentioned in the table applies to the \*marked coil.

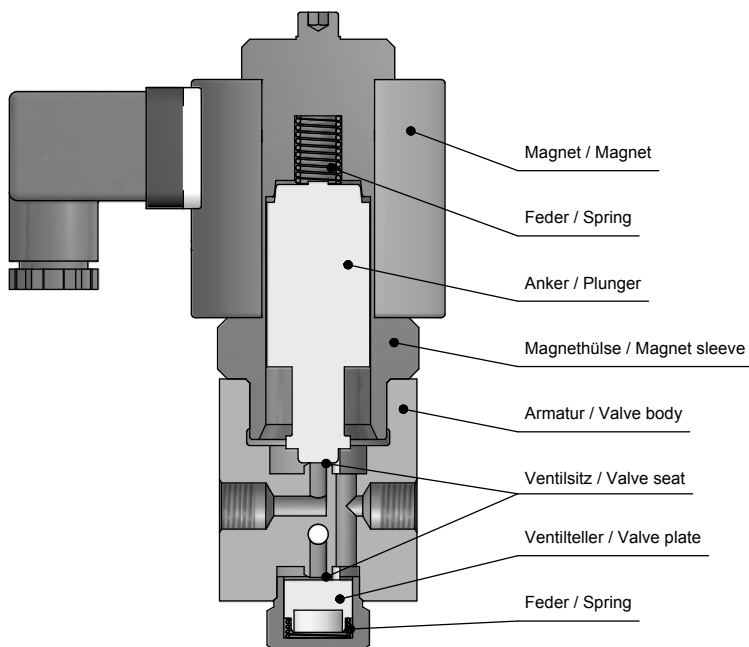

## DIMENSIONS

Coil	.802/ .808*	.322	.242/ .248*
Type	754.	754.	754.
G	1/4	1/4	1/4
B	49	63	77
C	70	77	93
J	28,5	28,5	38
K	90	122	142
L	50x50	50x50	60x60
t	9	9	12
kg	1,5	2,1	4,7

\*Differing dimension "C" for ATEX-coils

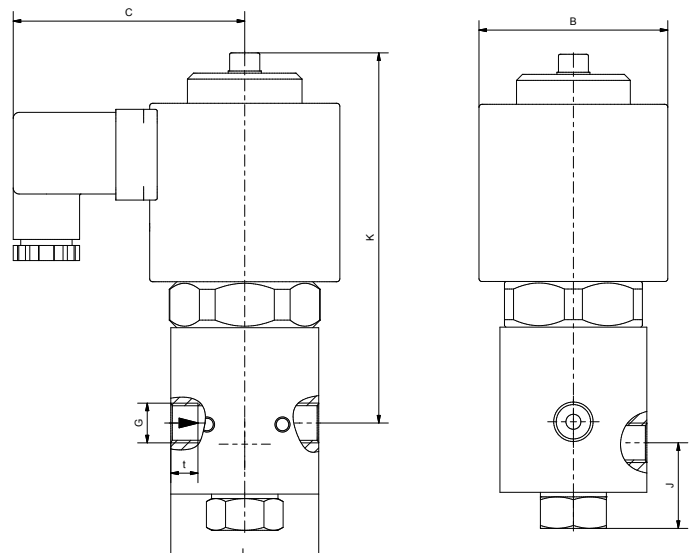

## INFORMATION

- It is imperative to observe the installation and safety instructions in our operating and service manuals.
- For information on our GSR ordering code, please refer to our catalogs. If you have any questions, we will be glad to assist you.
- Required ordering information: valve type, function NC/NO, pressure range, connection, nominal width, medium, flow rate, medium and ambient temperatures, connection voltage.
- **Detailed production-specific drawings and other technical information will be made available when an order is placed.**

## PLEASE NOTE

Each individual application decides which valve type is required, the main factor being the resistance of the materials to the operating medium. The correct selection of materials requires knowledge of the concentration, temperature and degree of contamination of the medium. Other criteria include the operating pressure and max. volumetric flow, since, in addition to high temperatures, high pressures and high flow rates must also be taken into account when selecting the materials.

**All materials used for our valves, be it housing, seals or magnets, will be carefully selected in view of the different application areas. Any information given is non-binding and serves for orientation only. No claims under warranty can be derived therefrom.**

### Heating and power of solenoid coils

The GSR default solenoid valves are designed for continuous operation (100% ED = power-on time) under normal operating conditions. The pulling force of a solenoid coil is basically influenced by three elements:

- The self-heating of the magnetic coil
- The medium temperature
- The ambient temperature

GSR solenoid coils are by default designed for a maximum ambient temperature of +40 °C. This specification applies for the maximum allowable operating pressure specified in the data sheet of the corresponding valve and a medium temperature of +80 °C.

A higher ambient temperature is possible, when lower values are applied for the other influencing parameters. When the max. operation pressure and max. ambient temperature of +50 °C is given the medium temperature is not allowed to be higher than max. +50 °C. In addition to that, deviations from the default design temperature range are possible, e.g. when temperature coils or other constructive measures are used. Please contact the GSR headquarters to discuss the specific application.

More precise specifications and technical data with regard to the operating conditions can be found in the data sheets of the solenoid coils and the solenoid valve regarded. Please observe that the surface temperature of a permanently loaded coil can amount up to +120 °C, solely by the self-heating of the coil. The power consumption of our default solenoid valves was calculated to DIN VDE 05820 for a coil temperature of +20 °C.

- The GSR logo is a registered trademark of GSR Ventiltechnik GmbH & Co. KG.
- Note: All texts and images are the property of GSR Ventiltechnik GmbH & Co. KG and must not be replicated or modified, not even in part, without written approval.
- Original products may differ from the product images shown, due to different materials and the like.
- Subject to error and changes.

**State: 11/2015, MK-MG, Version 2.**

