



Technical Data Sheet Type 37DT



Type 37DT

2/2-way solenoid valve
 NC - Valve normally closed (as standard)
 NO - Valve normally open (as option)

Force-pilot operated piston design valve. No differential pressure is necessary for operation. In standard (NC) the valve closes with spring power.

■ Solenoid valve for extended temperature range

TECHNICAL SPECIFICATIONS

| | |
|----------------------|--|
| Type of control | Force-pilot operated |
| Design | Piston design |
| Connection | Flanged DN15 - DN50 EN 1092-1 Form B1/B2 |
| Installation | With actuator upright |
| Pressure | 0 - 40 bar (see table on page 2) |
| Medium | Clean, neutral, gaseous and liquid media |
| max. viscosity | 22 mm ² /s |
| Temperature range | Medium: -40 °C up to +250 °C Ambient: -40 °C up to +50 °C <small>In consideration of the restrictions described on page 4</small> |
| Body material | Cast steel GP240 GH Stainless steel 1.4581 |
| Metallic inner parts | Stainless steel |
| Sealing | PEEK |
| Supply voltage | AC~ 24V, 110V, 230V <small>via external rectifier (included in delivery)</small> DC= 12V, 24V <small>Other supply voltages on request</small> |
| Voltage tolerance | -10% / +10% |
| Power consumption | T322 = 21 Watt T242 = 26 Watt T272 = 60 Watt |
| Protection class | IP65 acc. to DIN 60529 |
| Duty factor | 100% ED-VDE 0580 |
| Connection type | Terminal box |

VALVE FEATURES

- For media temperatures up to +250 °C
- No pressure difference is required
- High life time
- Simple compact valve design
- High-quality materials
- Reliable and sturdy sealing elements

FUNCTION

NC – non energized closed

NO – non-energized open

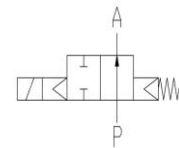
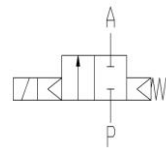

CERTIFICATES



ORDERING SYSTEM

| Type | Conn. | Housing | Seal | Coil | Option |
|--|-------|------------------------------------|------|----------------------|-------------------------|
| . 3 7 0 6 / | | 0 8 1 5 / | | T 2 7 2 - | D T |
| 01 DN15 02 DN20 03 DN25 04 DN32 05 DN40 06 DN50 | | 05 GP240 GH 08 St. steel 1.4581 | | T Temperature-design | DT Spacer unit + 250 °C |
| | | 15 PEEK | | | |

TECHNICAL FEATURES

| DN | Kv-value m ³ /h | Standard type | max. pressure for coils | | |
|----|----------------------------|--------------------|-------------------------|-------|------|
| | | | T322 | T242 | T272 |
| 15 | 5,0 | .3701/..15/....-DT | 0-10 | 0-32* | - |
| 20 | 11,0 | .3702/..15/....-DT | 0-6 | 0-25 | - |
| 25 | 13,0 | .3703/..15/....-DT | 0-6 | 0-25 | - |
| 32 | 24,0 | .3704/..15/....-DT | - | 0-6 | 0-25 |
| 40 | 27,0 | .3705/..15/....-DT | - | 0-6 | 0-25 |
| 50 | 42,0 | .3706/..15/....-DT | - | 0-6 | 0-25 |

The flow rate mentioned in the table applies to the strongest coil.

*max. 40 bar with special housing on request

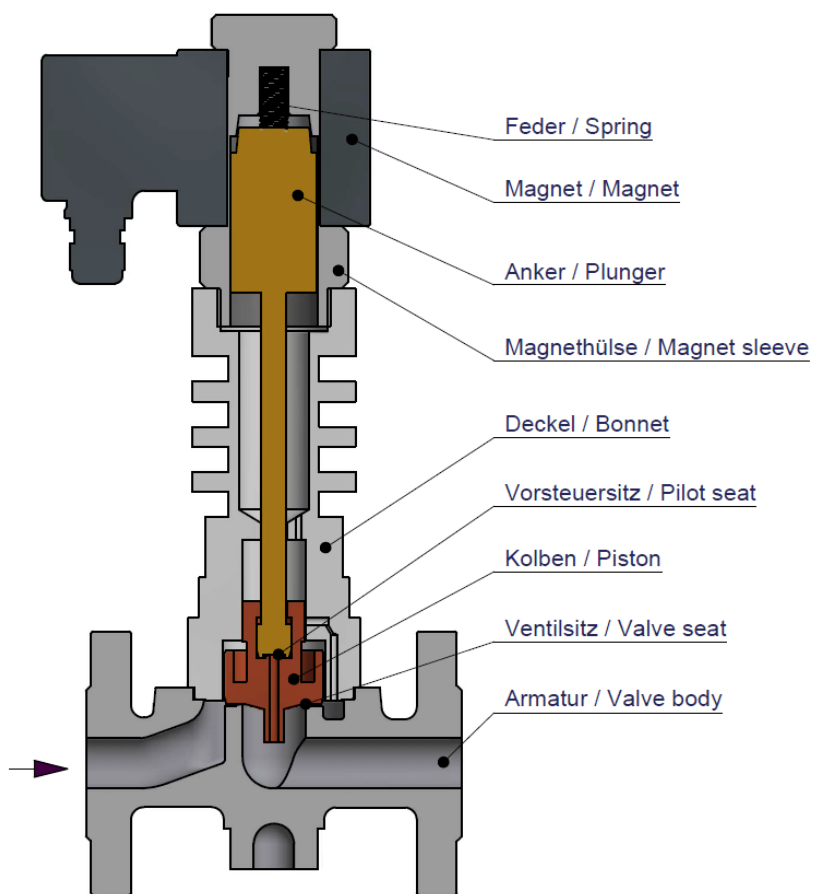

DIMENSIONS

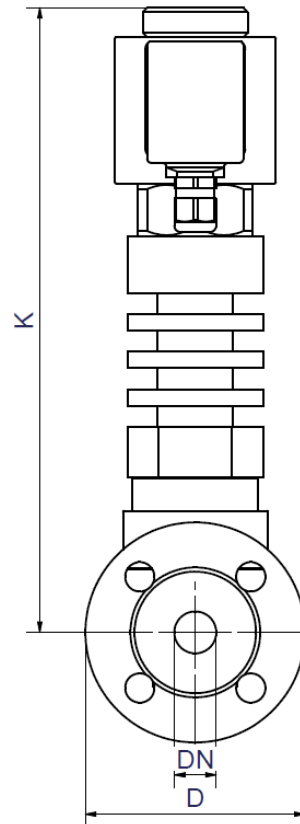
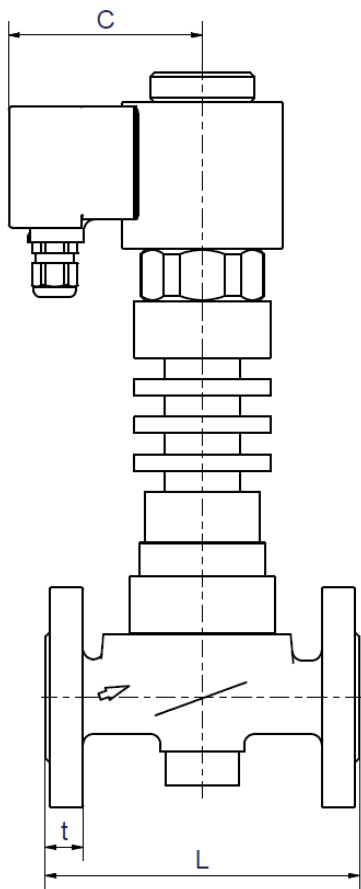

| Coil | T322 | | | T242 | | |
|------|-------|-------|-------|-------|-------|-------|
| Type | .3701 | .3702 | .3703 | .3701 | .3702 | .3703 |
| DN | 15 | 20 | 25 | 15 | 20 | 25 |
| C | 83 | 83 | 83 | 93 | 93 | 93 |
| D | 95 | 105 | 115 | 95 | 105 | 115 |
| K | 256 | 250 | 265 | 295 | 298 | 283 |
| L | 130 | 150 | 160 | 130 | 150 | 160 |
| t | 16 | 18 | 18 | 16 | 18 | 18 |
| kg | 3,9 | 5,5 | 5,8 | 7,5 | 7,7 | 6,8 |

| Coil | T242 | | | T272 | | |
|------|-------|-------|-------|-------|-------|-------|
| Type | .3704 | .3705 | .3706 | .3704 | .3705 | .3706 |
| DN | 32 | 40 | 50 | 32 | 40 | 50 |
| C | 93 | 93 | 93 | 107 | 107 | 107 |
| D | 140 | 150 | 165 | 140 | 150 | 165 |
| K | 299 | 299 | 299 | 335 | 335 | 358 |
| L | 180 | 200 | 230 | 180 | 200 | 230 |
| t | 18 | 18 | 20 | 18 | 18 | 20 |
| kg | 9,6 | 10,1 | 12,6 | 11,2 | 11,4 | 14,9 |

INFORMATION

- It is imperative to observe the installation and safety instructions in our operating and service manuals.
- For information on our GSR ordering code, please refer to our catalogs. If you have any questions, we will be glad to assist you.
- Required ordering information: valve type, function NC/NO, pressure range, connection, nominal width, medium, flow rate, medium and ambient temperatures, connection voltage.
- **Detailed production-specific drawings and other technical information will be made available when an order is placed**

PLEASE NOTE

Each individual application decides which valve type is required, the main factor being the resistance of the materials to the operating medium. The correct selection of materials requires knowledge of the concentration, temperature and degree of contamination of the medium. Other criteria include the operating pressure and max. volumetric flow, since, in addition to high temperatures, high pressures and high flow rates must also be taken into account when selecting the materials.

All materials used for our valves, be it housing, seals or magnets, will be carefully selected in view of the different application areas. Any information given is non-binding and serves for orientation only. No claims under warranty can be derived therefrom.

Heating and power of solenoid coils

The GSR default solenoid valves are designed for continuous operation (100% ED = power-on time) under normal operating conditions. The pulling force of a solenoid coil is basically influenced by three elements:

- The self-heating of the magnetic coil
- The medium temperature
- The ambient temperature

GSR solenoid coils are by default designed for a maximum ambient temperature of +35 °C. This specification applies for the maximum allowable operating pressure specified in the data sheet of the corresponding valve, 100% duty cycle and a medium temperature of +250 °C.

A higher ambient temperature is possible, when lower values are applied for the other influencing parameters. When the max. operation pressure and max. ambient temperature of +50 °C is given the medium temperature is not allowed to be higher than max. +200 °C. In addition to that, deviations from the default design temperature range are possible, e.g. when temperature coils or other constructive measures are used. Please contact the GSR headquarters to discuss the specific application.

More precise specifications and technical data with regard to the operating conditions can be found in the data sheets of the solenoid coils and the solenoid valve regarded. Please observe that the surface temperature of a permanently loaded coil can amount up to +120 °C, solely by the self-heating of the coil. The power consumption of our default solenoid valves was calculated to DIN VDE 05820 for a coil temperature of +20 °C.

- The GSR logo is a registered trademark of GSR Ventiltechnik GmbH & Co. KG.
- Note: All texts and images are the property of GSR Ventiltechnik GmbH & Co. KG and must not be replicated or modified, not even in part, without written approval.
- Original products may differ from the product images shown, due to different materials and the like.
- Subject to error and changes.

Stand: 03.19, MK-MG, Version 1.