



Technical Data Sheet Type 8/100



2/2-way pressure controlled valve
NC - Valve normally closed

Direct pressure controlled valve. The valve seat is opened against a spring force via the control medium.

In standard (NC) the valve closes with spring power.

■ **Pressure controlled valve for high pressure applications**

Type 8/100

TECHNICAL SPECIFICATIONS

Type of control	Direct pressure operated
Design	Piston design
Connection	Threaded G1/8 - G1/4 - DIN ISO 228/1 (BSP) Threaded 7/16 UNF - 9/16 UNF (Autoclave)
Installation	Preferable with actuator upright
Pressure	0 - 1200 bar (see table on page 2)
Medium	Clean, neutral, gaseous and liquid media
Viscosity	22 mm ² /s
Temperature range	Medium: -40 °C up to +80 °C Ambient: -40 °C up to +60 °C
Body material	Stainless steel 1.4301
Metallic inner parts	Stainless steel
Sealing	PEEK, metallic
Pilot pressure	4 - 10 bar
Pilot medium	Clean and neutral gases

Pilot valve **A7231/1002/....**



3/2-way direct operated, NC
G1/8, orifice 1.5mm, 0-8 bar
Brass / Stainless steel / FKM

VALVE FEATURES

- For high pressure applications up to 1200 bar
- No pressure difference required
- High life time
- Simple compact valve design
- High-quality materials
- Reliable and sturdy sealing elements

FUNCTION

NC – non energized closed

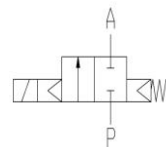

CERTIFICATES



ORDERING SYSTEM

Valve type					Actuator			Options													
8	/	1	0	0	-	4	9	-	1	2	1	5	-	7	0	1	3	-	T	T	
Anschluss					Body material					Actuator					Options						
3E 7/16 UNF					12 Edelstahl 1.4435					03 30 mm					Autoclave thread						
31 G 1/8										05 50 mm											
45 G 1/4 - 7/16 UNF										08 80 mm											
49 G 3/4 - 7/16 UNF					15 PEEK					13 125 mm											
															70 Standard actuator						
															73 Actuator stainless st.						
															75 Actuator chem. nickel plated						

TECHNICAL FEATURES

G	Seat Ø mm	Kv-value m³/h	Standard type	max. pressure with actuator			
				7303	7505	7008	7013
1/8	1,0		8/100-31-1215-....	0-500	-	-	-
1/4	4,0		8/100-45-1215-....	-	0-500	-	-
1/4	8,0		8/100-49-1215-....	-	-	0-400	-
7/16 UNF	0,5		8/100-3E-1215-....-TT	0-1000	-	-	-
9/16 UNF	4,0		8/100-45-1215-....-TT	-	-	0-700	-
9/16 UNF	8,0		8/100-49-1215-....-TT	-	-	-	0-1200

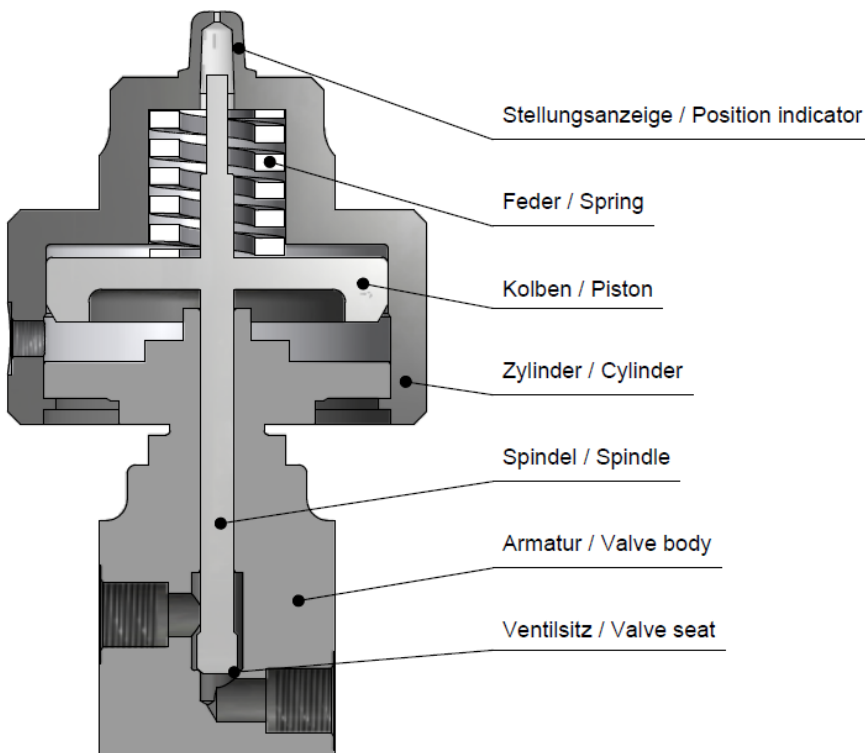

DIMENSIONS

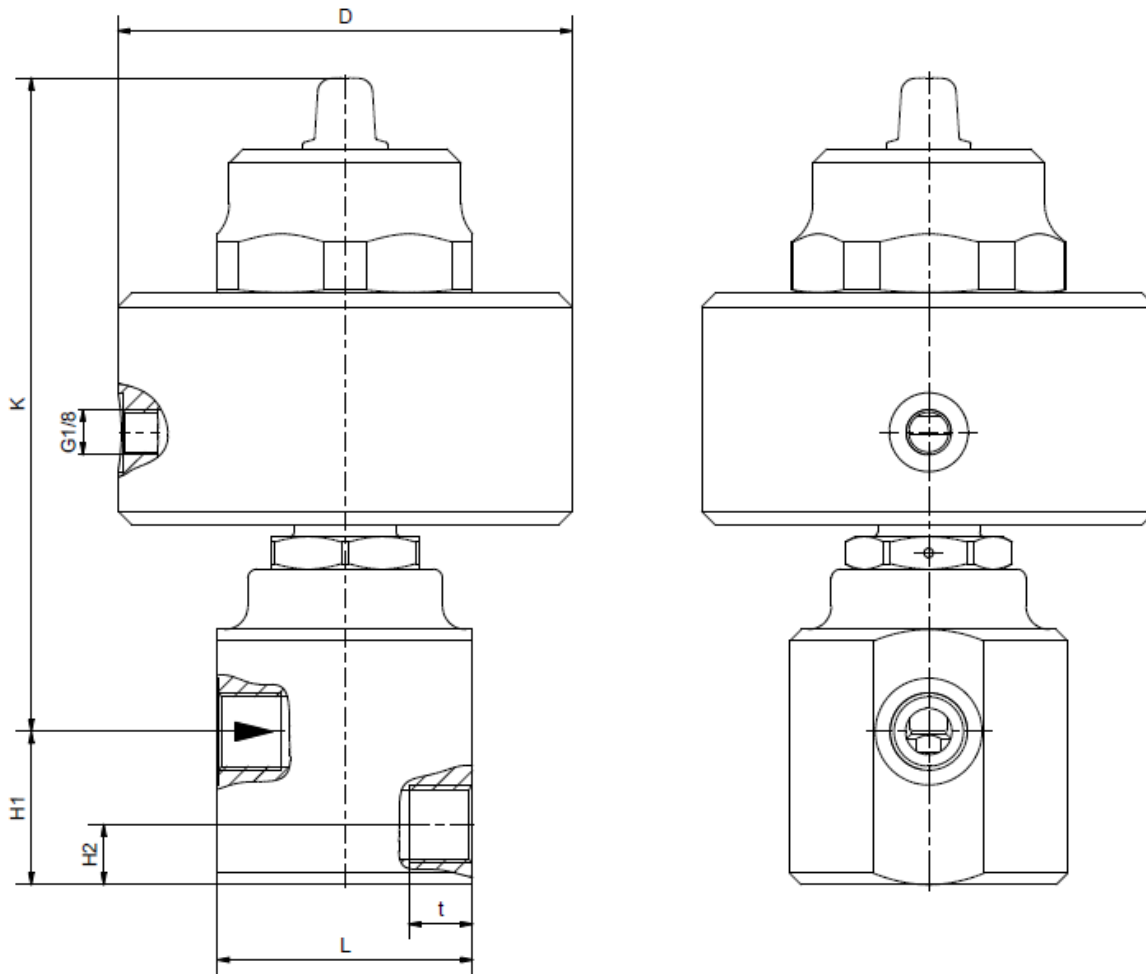

Type	8/100-31	8/100-45	8/100-49	8/100-3E-TT	8/100-45-TT	8/100-49-TT
G	1/8	1/4	1/4	7/16 UNF	9/16 UNF	9/16 UNF
D	on request	61	98	on request	98	149
K		143	141		141	192
H1		33	33		33	33
H2		13	13		13	13
L		55	55		55	55
t		13,5	13,5		10	10
kg		2,3	2,6		2,6	4,9

INFORMATION

- It is imperative to observe the installation and safety instructions in our operating and service manuals.
- For information on our GSR ordering code, please refer to our catalogs. If you have any questions, we will be glad to assist you.
- Required ordering information: valve type, function NC/NO, pressure range, connection, nominal width, medium, flow rate, medium and ambient temperatures, connection voltage.
- **Detailed production-specific drawings and other technical information will be made available when an order is placed**

PLEASE NOTE

Each individual application decides which valve type is required, the main factor being the resistance of the materials to the operating medium. The correct selection of materials requires knowledge of the concentration, temperature and degree of contamination of the medium. Other criteria include the operating pressure and max. volumetric flow, since , in addition to high temperatures , high pressures and high flow rates must also be taken into account when selecting the materials.

All materials used for our valves, be it housing, seals or magnets, will be carefully selected in view of the different application areas. Any information given is non-binding and serves for orientation only. No claims under warranty can be derived therefrom.

- The GSR logo is a registered trademark of GSR Ventiltechnik GmbH & Co. KG.
- Note: All texts and images are the property of GSR Ventiltechnik GmbH & Co. KG and must not be replicated or modified, not even in part, without written approval.
- Original products may differ from the product images shown, due to different materials and the like.
- Subject to error and changes.

Stand: 01.17, MK-MG, Version 1.