



Technical Data Sheet Type 79



- 3/2-way pressure operated valve
- NC - Valve normally closed (as standard)
- NO - Valve normally open (as option)
- DW - Valve with double acting actuator (as option)

Direct pressure controlled valve. The valve seat is opened against a spring force via the control medium.

■ Valve for clean, gaseous and liquid media

Type 79

TECHNICAL SPECIFICATIONS

Type of control	Direct-pressure operated
Design	Poppet design
Connection	Flanged DN15 - DN150 EN 1092-1 Form B1/B2
Installation	Preferable with actuator upright
Pressure	0 - 16 bar (see table on page 2)
Medium	Clean, neutral, gaseous and liquid media
max. viscosity	400 mm ² /s
Temperature range	Medium: -40 °C up to +200 °C Ambient: -10 °C up to +60 °C
Body material	Spheroidal graphite EN-GJS-400-18-LT Cast iron EN-GJL-250 Cast steel GP240 GH
Metallic inner parts	Brass and Stainless steel
Sealing	NBR, PTFE
Pilot pressure	4 - 10 bar max pressure with at least 6 bar
Pilot medium	Clean and neutral gases Other pilot media on request

Pilot valve	2/131-31-1702-C182
-------------	---------------------------



3/2-way direct operated, NC
G1/8, orifice 1.5mm, 0-8 bar
Aluminum / Stainless steel / FKM
with Cnomo-coil as well as with
integrated screw connection for
easy assembly

	A7231/1002/....
--	------------------------



3/2-way direct operated, NC
G1/8, orifice 1.5mm, 0-8 bar
Brass / Stainless steel / FKM

VALVE FEATURES

- No pressure difference required
- High life time
- High-quality materials
- Reliable and sturdy sealing elements
- Long-term availability of spare parts
- NO - non-pressurized open as option
- DW - double acting as option

FUNCTION

NC – non
pressurized
closed

NO – non
pressurized open

DW - double
acting

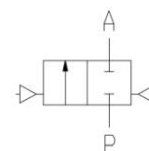
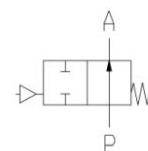
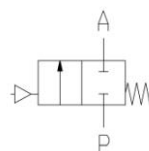

CERTIFICATES



ORDERING SYSTEM

Type	Conn.	Housing	Seal	Actuator	Option
. 7 9	0 3	/ 0 4	0 1	/ 7 0 1 3	- H A
01 DN15		03 EN-GIS-400-18-LT		7 . Normally closed	
02 DN20		04 EN-GIL-250		8 . Normally open	
03 DN25		05 GP240 GH		9 . Double acting	
04 DN32			01 NBR	. 0 Standard actuator	
05 DN40			04 PTFE	. 3 Act. Stainless steel	
06 DN50				. 5 Act. chem. nickel pl.	
07 DN65					. 5 50 mm
08 DN80					. 8 80 mm
09 DN100					. 3 125 mm
10 DN125					
11 DN150					

TECHNICAL FEATURES

Type 79

DN	Seat Ø mm	Kv-value m³/h	Standard type	max. pressure with actuator					
				7.05		7.08		7.13	
				NC	UN	NC	UN	NC	UN
15	21	6,8	.7901/0501/	0-5	0-4	0-16	0-12	-	-
20	21	8,8	.7902/..01/	0-5	0-4	0-16	0-12	-	-
25	27	11,5	.7903/..01/	0-3	0-3	0-14	0-8	0-16	0-16
32	31	18,0	.7904/..01/	-	-	0-9	0-8	0-16	0-16
40	41	26,0	.7905/..01/	-	-	0-3	0-3	0-16	0-16
50	51	38,0	.7906/..01/	-	-	0-2	0-2	0-16	0-16
65	66	62,0	.7907/..01/	-	-	-	-	0-16	0-15
80	80		.7908/..01/	-	-	-	-	0-10	0-10
100	100		.7909/..01/	-	-	-	-	0-10	0-10
125	125		.7910/..01/	-	-	-	-	0-8	0-8
150	150		.7911/..01/	-	-	-	-	0-8	0-8

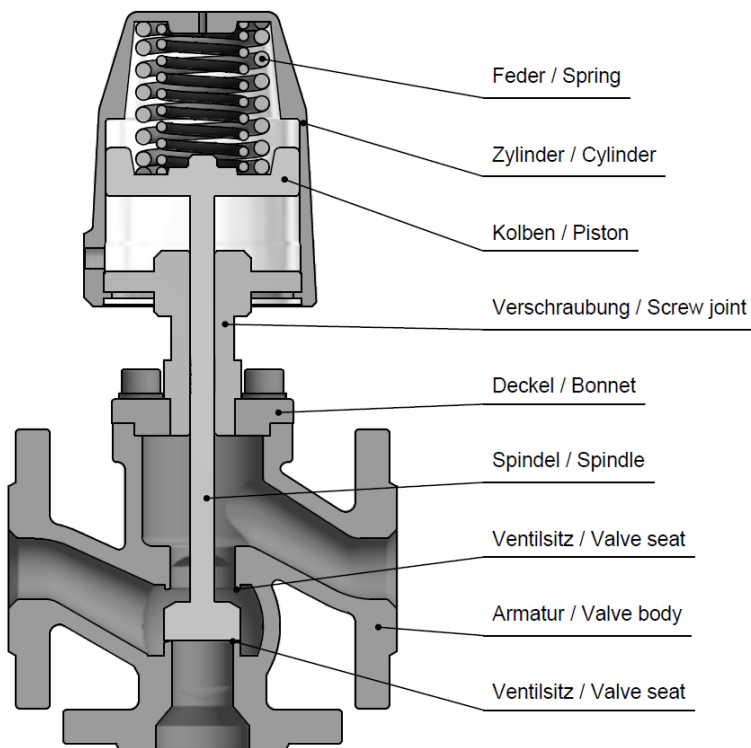

DIMENSIONS

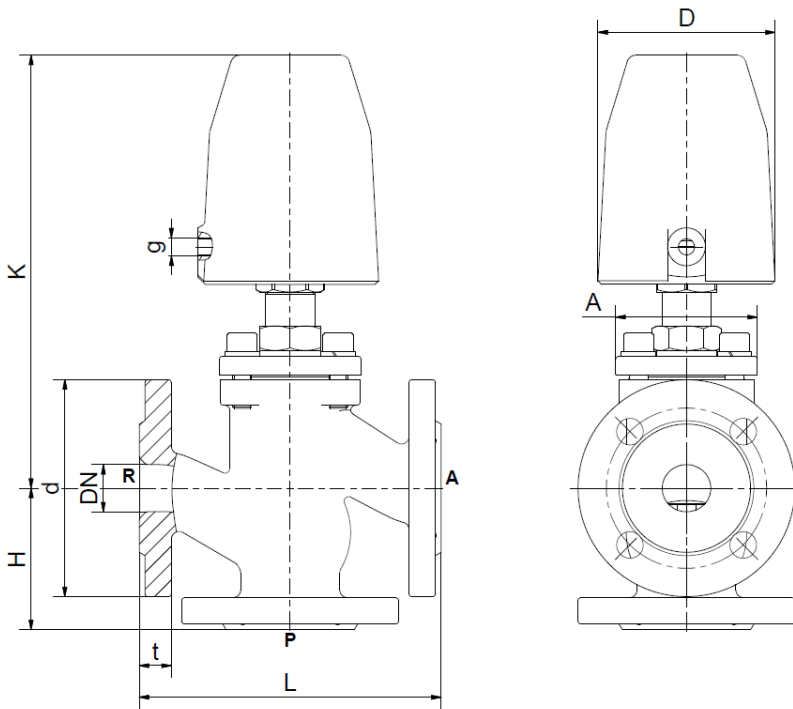

Type 79

Actuator	7.05			7.08					
Type	.7901	.7902	.7903	.7901	.7902	.7903	.7904	.7905	.7906
DN	15	20	25	15	20	25	32	40	50
A	75	75	75	75	75	75	75	90	100
d	95	105	115	95	105	115	140	150	165
D	62	62	62	94	94	94	94	94	94
H	65	70	75	65	70	75	75	90	100
K	205	205	196	226	226	230	255	265	260
L	130	150	160	130	150	160	180	200	230
g	1/8	1/8	1/8	1/8	1/8	1/8	1/8	1/8	1/8
t	14	16	17	14	16	17	18	19	21
kg	4,5	5,5	6,7	4,8	6,0	7,0	10,0	12,5	15,0

Actuator	7.13								
Type	.7903	.7904	.7905	.7906	.7907	.7908	.7909	.7910	.7911
DN	25	32	40	50	65	80	100	125	150
A	75	75	90	100	112	136	195	235	295
d	115	140	150	165	185	200	220	270	300
D	141	141	141	141	141	141	141	141	141
H	75	75	90	100	120	130	150	200	300
K	315	340	360	370	390	415	430	470	460
L	160	180	200	230	290	310	350	400	480
g	1/4	1/4	1/4	1/4	1/4	1/4	1/4	1/4	1/4
t	17	18	19	21	22	24	25	26	28
kg	10,0	12,5	16,5	18,5	26,5	34,0	48,0	77,0	134,0

INFORMATION

- It is imperative to observe the installation and safety instructions in our operating and service manuals.
- For information on our GSR ordering code, please refer to our catalogs. If you have any questions, we will be glad to assist you.
- Required ordering information: valve type, function NC/NO, pressure range, connection, nominal width, medium, flow rate, medium and ambient temperatures, connection voltage.
- **Detailed production-specific drawings and other technical information will be made available when an order is placed**

PLEASE NOTE

Each individual application decides which valve type is required, the main factor being the resistance of the materials to the operating medium. The correct selection of materials requires knowledge of the concentration, temperature and degree of contamination of the medium. Other criteria include the operating pressure and max. volumetric flow, since , in addition to high temperatures , high pressures and high flow rates must also be taken into account when selecting the materials.

All materials used for our valves, be it housing, seals or magnets, will be carefully selected in view of the different application areas. Any information given is non-binding and serves for orientation only. No claims under warranty can be derived therefrom.

- The GSR logo is a registered trademark of GSR Ventiltechnik GmbH & Co. KG.
- Note: All texts and images are the property of GSR Ventiltechnik GmbH & Co. KG and must not be replicated or modified, not even in part, without written approval.
- Original products may differ from the product images shown, due to different materials and the like.
- Subject to error and changes.

Stand: 08.17, MK-MG, Version 1.