

Technical Data Sheet Type 63



- 2/2-way pressure controlled valve
- NC - Valve normally closed (as standard)
- NO - Valve normally open (as option)
- DW - Valve with double acting actuator (as option)

Direct pressure controlled valve. The valve seat is opened against a spring force via the control medium.

■ **Valve for clean, gaseous and liquid media**

TECHNICAL SPECIFICATIONS

Type of control	Direct pressure operated
Design	Poppet design
Connection	Threaded acc. to DIN 228/1 (BSP) Further connections like NPT on request
Installation	Preferable with actuator upright
Pressure	0 - 40 bar (see table on page 2)
Medium	Clean, neutral, gaseous and liquid media
max. viscosity	600 mm ² /s
Temperature range	Medium: -40 °C up to +200 °C Ambient: -10 °C up to +60 °C Depending on the sealing material
Body material	Red brass RG5 / Brass 2.0402 Stainless steel 1.4408
Metallic inner parts	Red brass / Brass and Stainless steel
Sealing	NBR, FKM, EPDM, PTFE Seat PTFE (further on request)
Pilot pressure	4 - 10 bar
Pilot medium	Clean and neutral gases Other pilot media on request
Pilot valve	2/131-31-1702-C182



3/2-way direct operated, NC
G1/8, orifice 1.5mm, 0-8 bar
Aluminum / Stainless steel / FKM
with Cnomo-coil as well as with
integrated screw connection for
easy assembly

Pilot valve	A7231/1002/....
-------------	------------------------



3/2-way direct operated, NC
G1/8, orifice 1.5mm, 0-8 bar
Brass / Stainless steel / FKM

VALVE FEATURES

- No pressure difference required
- High life time
- High-quality materials
- Reliable and sturdy sealing elements
- Long-term availability of spare parts
- NO - non-pressurized open as option
- DW - double acting as option

FUNCTION

NC – non
pressurized
closed

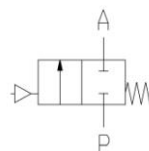

NO – non
pressurized open

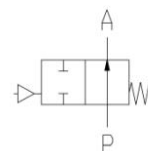

DW - double
acting

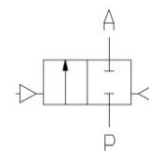

CERTIFICATES



Special design available for temperature ranges **-40 °C up to +300 °C** and **+160 °C** ambient.

Specification and drawings on request.

ORDERING SYSTEM

Type	Conn.	Housing	Seal	Actuator	Option
. 6 3	2 3	/ 1 1	0 1	/ 7 1 0 5	- H A
	23 G 1/2 24 G 3/4 25 G 1 26 G 1 1/4 27 G 1 1/2 28 G 2 29 G 2 1/2 30 G 3	08 Stainl. st. 1.4408 10 Brass 2.0402 11 Red brass RG5	01 NBR 02 FKM 04 PTFE 06 EPDM	7. Normally closed 8. Normally open 9. Double acting . 1 Standard actuator . 3 Act. Stainless steel . 5 Act. chem. nickel pl.	. 5 50 mm . 8 80 mm . 3 125 mm

TECHNICAL FEATURES

				max. pressure with actuator					
G	Seat Ø mm	Kv-value m³/h	Standard type	7.05		7.08		7.13	
				Rotguss	Edelstahl	Rotguss Messing	Edelstahl	Rotguss Messing	Edelstahl
1/2	12	4,6	.6323/..01(04)/7...	0-16	0-40	-	-	-	-
3/4	16	6,4	.6324/..01(04)/7...	0-16	0-20	-	0-40	-	-
1	23	8,4	.6325/..01(04)/7...	0-16	0-16	0-16	0-25	-	0-40
1 1/4	29	21,5	.6326/..01(04)/7...	0-10	0-10	0-16	0-25	-	0-40
1 1/2	35	27,0	.6327/..01(04)/7...	0-8	0-8	0-16	0-20	0-16	0-40
2	43	45,0	.6328/..01(04)/7...	0-4	0-4	0-12	0-12	0-16	0-20
2 1/2	63	82,0	.6329/..01(04)/7...	-	-	0-6	0-6	0-10	0-10
3	76	125,0	.6330/..01(04)/7...	-	-	0-4	0-4	0-10	0-10

				max. Druck bei Ausführung gegen den Mediendruck schließend					
G	Seat Ø mm	Kv-value m³/h	Standard type	7.15 / 7.55		7.58		7.63	
				Rotguss	Edelstahl	Rotguss Messing	Edelstahl	Rotguss Messing	Edelstahl
1/2	12	4,6	.6323/..01(04)/7...	0-16	0-40	-	-	-	-
3/4	16	6,4	.6324/..01(04)/7...	0-16	0-20	-	0-40	-	-
1	23	8,4	.6325/..01(04)/7...	0-10	0-10	0-16	0-22	-	0-40
1 1/4	29	21,5	.6326/..01(04)/7...	0-7	0-7	0-10	0-10	0-16	0-40
1 1/2	35	27,0	.6327/..01(04)/7...	0-6	0-6	0-8	0-8	0-16	0-30
2	43	45,0	.6328/..01(04)/7...	0-3	0-3	0-5	0-5	0-16	0-20
2 1/2	63	82,0	.6329/..01(04)/7...	-	-	0-1	0-1	0-8,5	0-8,5
3	76	125,0	.6330/..01(04)/7...	-	-	0-0,7	0-0,7	0-5	0-5

Values in brackets refer to the standard sealing material for stainless steel version
 Specification of pressure valid for at least 6 bar control pressure

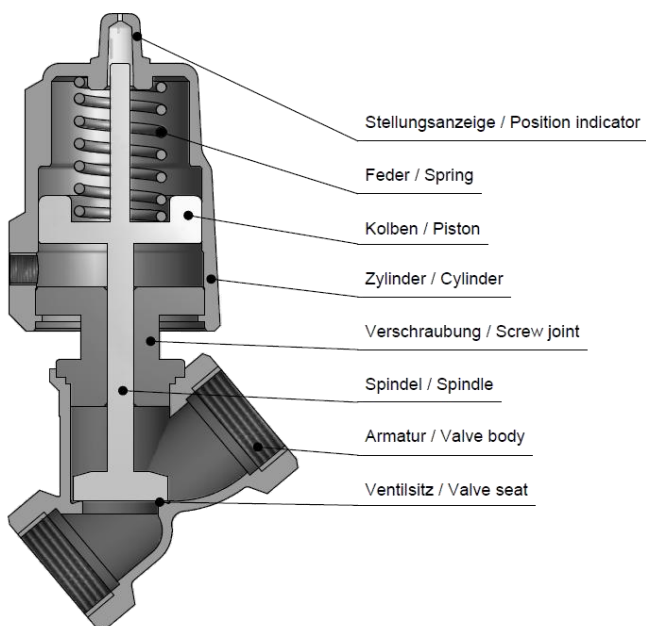

DIMENSIONS

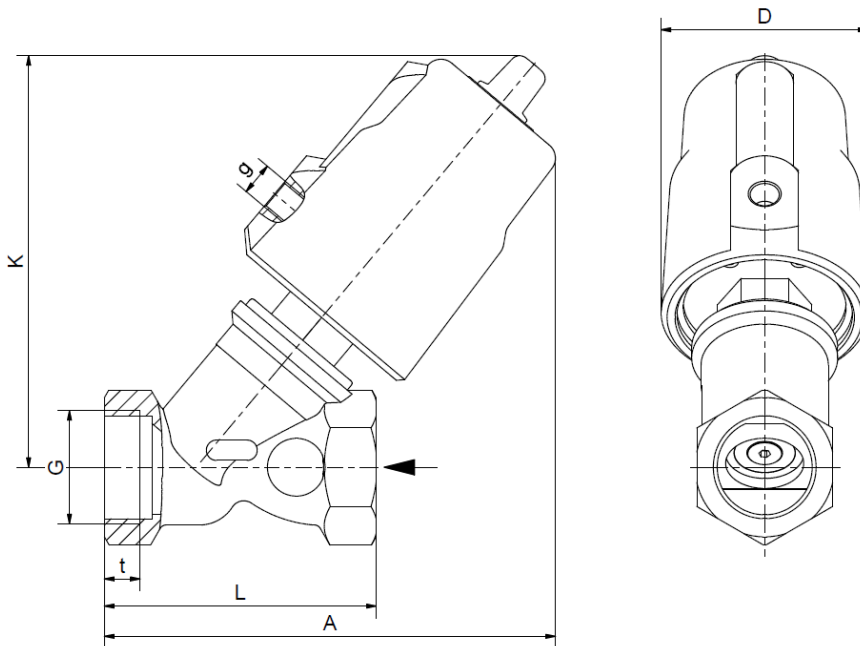

Type 63

Actuator	7.05						7.08		
Type	6323	6324	6325	6326	6327	6328	6324	6325	6326
G	1/2	3/4	1	1 1/4	1 1/2	2	3/4	1	1 1/4
A	123	130	133	153	162	171	174	175	185
D	62	62	62	62	62	62	94	94	94
K	113	118	122	139	146	155	170	168	174
L	66	75	80	97	107	124	75	80	97
	(65)	(75)	(90)	(110)	(120)	(150)	(75)	(90)	(110)
g	1/8	1/8	1/8	1/8	1/8	1/8	1/8	1/8	1/8
t	13 (12)	15 (13)	11 (15)	13 (17)	15 (19)	17 (21)	15 (13)	11 (15)	13 (17)
kg	1,3	1,4	1,5	2,0	2,3	3,0	1,6	1,8	2,2

The values in brackets apply to the stainless steel version.

Actuator	7.08				7.13					
Type	6327	6328	6329	6330	6325	6326	6327	6328	6329	6330
G	1 1/2	2	2 1/2	3	1	1 1/4	1 1/2	2	2 1/2	3
A	192	203	247	265	240	250	255	261	307	325
D	94	94	94	94	140	140	140	140	140	140
K	181	190	205	211	239	245	250	254	267	273
L	107	124	178	195	80	97	107	124	178	195
	(120)	(150)			(90)	(110)	(120)	(150)		
g	1/8	1/8	1/8	1/8	1/4	1/4	1/4	1/4	1/4	1/4
t	15 (19)	17 (21)	28	28	11 (15)	13 (17)	15 (19)	17 (21)	28	28
kg	2,5	3,3	5,5	7,0	4,5	4,8	4,5	5	7,4	9,0

The values in brackets apply to the stainless steel version.



INFORMATION

- It is imperative to observe the installation and safety instructions in our operating and service manuals.
- For information on our GSR ordering code, please refer to our catalogs. If you have any questions, we will be glad to assist you.
- Required ordering information: valve type, function NC/NO, pressure range, connection, nominal width, medium, flow rate, medium and ambient temperatures, connection voltage.
- **Detailed production-specific drawings and other technical information will be made available when an order is placed**

PLEASE NOTE

Each individual application decides which valve type is required, the main factor being the resistance of the materials to the operating medium. The correct selection of materials requires knowledge of the concentration, temperature and degree of contamination of the medium. Other criteria include the operating pressure and max. volumetric flow, since , in addition to high temperatures , high pressures and high flow rates must also be taken into account when selecting the materials.

All materials used for our valves, be it housing, seals or magnets, will be carefully selected in view of the different application areas. Any information given is non-binding and serves for orientation only. No claims under warranty can be derived therefrom.

- The GSR logo is a registered trademark of GSR Ventiltechnik GmbH & Co. KG.
- Note: All texts and images are the property of GSR Ventiltechnik GmbH & Co. KG and must not be replicated or modified, not even in part, without written approval.
- Original products may differ from the product images shown, due to different materials and the like.
- Subject to error and changes.

Stand: 05.18, MK-MG, Version 2