

VS - Series

- Max. vacuum level : -93 kPa (-27.46 inHg)
- Max. flow rate : 341 NI/min (12.04 scfm)
- Supply air pressure : 3 ~ 6 bar, max 7 bar
(43.5~87 psi, max 101.5 psi)
- Air consumption : 97~152 NI/min (3.43~5.37 scfm)
- Supply air type : Dry compressed air
- Working temperature : -20°C to +80°C
- Noise level : 50~60 dBA



Main advantages

- High operational reliability despite fluctuating.
- Quick response time.
- VMECA Twofold Silencer^{PT} assures low noise levels.
- Easy to distribute vacuum. (Multiple connection alternatives up to 9 ports.)
- Optional Air-Saving(AS)kit available to minimize energy consumption.
- Optional factory installed air control/vacuum release valves and vacuum switch available.
- Easily mountable and interchangeable vacuum cartridge.

Order No.

VS 144 - AS - A3 R3 - CL A - S2 N V

① ② ③ ④ ⑤ ⑥ ⑦ ⑧ ⑨

① Vacuum Port

- **144** - G1/4" X 4EA
- 146 - G1/4" X 6EA
- 148 - G1/4" X 8EA

② Air saving kit (108)

No mark - Standard

- **AS** - Air saving kit attached

③ Voltage of air supply control valve

A1 - AC110V

A2 - AC220V

- **A3** - DC24V

D1* - AC110V

D2* - AC220V

D3* - DC24V

* D.. : Double solenoid valve is available only with 'DN' or 'DL', section ⑤

④ Voltage of vacuum release control valve

R1 - AC110V

R2 - AC220V

- **R3** - DC24V

⑤ Solenoid Terminal

DN - DIN type without lead wire

DL - DIN type with lamp without lead wire

- **CL*** - Connector type with lamp & 0.3 m lead wire

2B* - DIN type with '2 in 1' BUS cable
(Air control v/v + Vacuum release v/v)

3B* - DIN type with '3 in 1' BUS cable
(Air control v/v + Vacuum release v/v + Digital switch)

* Can not available with double solenoid valve

※ Remark

CL : Available only with DC24V

3B : Available only with DC24V

Available only with 'S2' or 'S2P', section ⑦

☞ About 'BUS cable' (340, 341)

⑥ Vacuum release flow adjust

No mark - Standard

- **A** - Attached

⑦ Vacuum switch

No mark - Vacuum gauge.

- **S2(P)** - Digital display output 2points, No analog supply M8-4Pin Connector type 0.3m lead wire.

SG2(P) - Digital display output 2 points, No analog supply Grommet type 4-Core 2m lead wire.

SG3(P) - Digital display output 2 points, Analog supply Grommet type 5-Core 2m lead wire.

※ Remark: ① S..(P)

↳ Output type :PNP open collector

② VCM8 42 : M8-4Pin connector wire.
Only for type S2 or S2(P).

⑧ Non-return valve

No mark - Standard

- **N** - Non-return valve.

⑨ Sealing

No mark - Standard

- **V** - Viton[®]

E - EPDM

Performance Data

Series	MAX. Vacuum (-kPa)	Feed pressure (MPa)	Vacuum flow, NI/min, at different vacuum levels -kPa (-mmHg)									
			0 (0)	10 (75)	20 (150)	30 (225)	40 (300)	50 (375)	60 (450)	70 (525)	80 (600)	90 (675)
VS	75	0.22	302	122.5	88	53	31.4	28.5	16.5	4.6	-	-
	93	0.3	338	152	106	64	33	32	22	16.5	6.4	1.9
	93	0.4	341	154	127.5	94	69	43	23.3	17.3	6.9	2.1

Series	Feed pressure (MPa)	Air consumption (NI/min)	Time, s/l, to evacuate a volume to different vacuum levels -kPa (-mmHg)								
			10 (75)	20 (150)	30 (225)	40 (300)	50 (375)	60 (450)	70 (525)	80 (600)	90 (675)
VS	0.22	97	0.019	0.09	0.1	0.32	0.42	0.73	1.62	-	-
	0.3	118	0.015	0.07	0.18	0.28	0.38	0.64	0.8	12	3.8
	0.4	152	0.01	0.48	0.07	0.09	0.2	0.42	0.8	1	3.4

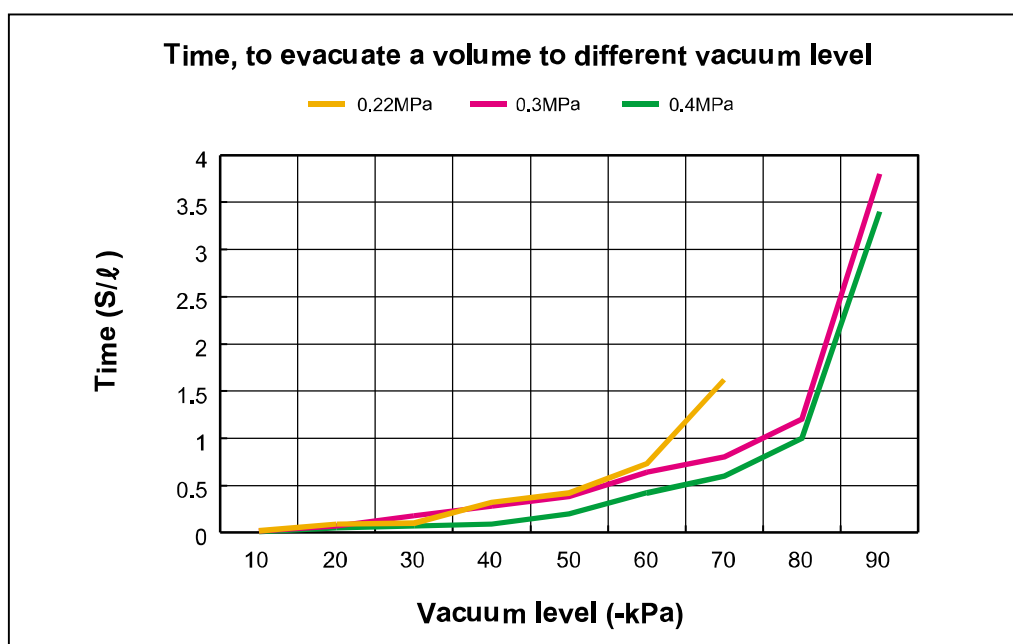
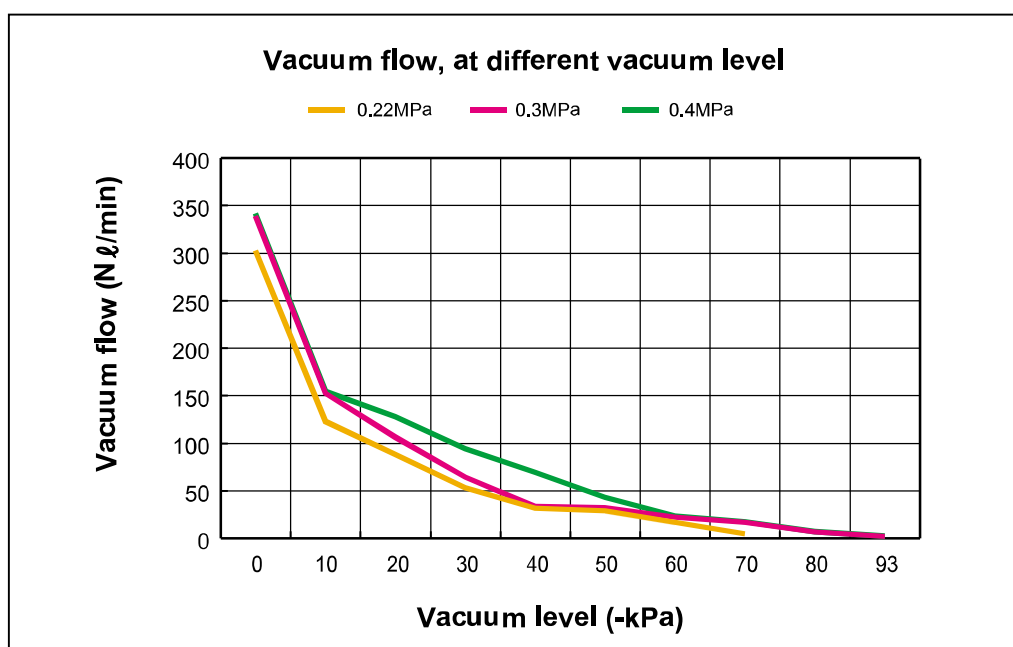

VLS-Series

- Max. vacuum level : -75 kPa (-22.15 inHg)
- Max. flow rate : 362 NI/min (12.79 scfm)
- Supply air pressure : 4 ~ 6 bar, max 7 bar
(58~87 psi, max 101.5 psi)
- Air consumption : 70~104 NI/min (2.47~3.67 scfm)
- Supply air type : Dry compressed air
- Working temperature : -20°C to +80°C
- Noise level : 50~60 dBA



Main Advantages

- High operational reliability despite fluctuating.
- Quick response time.
- VMECA Twofold Silencer^{PT} assures low noise levels.
- Easy to distribute vacuum. (Multiple connection alternatives up to 8 ports.)
- Optional Air-Saving(AS) kit available to minimize energy consumption.
- Optional factory installed air control/vacuum release valves and vacuum switch available.
- Easily mountable and interchangeable vacuum cartridge.

Order No.

VLS 144 - AS - A3 R3 - CL A - S2 N V

① ② ③ ④ ⑤ ⑥ ⑦ ⑧ ⑨

① Vacuum Port

- **144** - G1/4" X 4EA
- 146 - G1/4" X 6EA
- 148 - G1/4" X 8EA

② Air saving kit (108)

- No mark - Standard
- **AS** - Air saving kit attached

③ Voltage of air supply control valve

- A1 - AC110V
- A2 - AC220V
- **A3** - DC24V
- D1* - AC110V
- D2* - AC220V
- D3* - DC24V

* D.. : Double solenoid valve is available only with 'DN' or 'DL', section ⑤

④ Voltage of vacuum release control valve

- R1 - AC110V
- R2 - AC220V
- **R3** - DC24V

⑤ Solenoid Terminal

- DN - DIN type without lead wire
- DL - DIN type with lamp without lead wire
- **CL*** - Connector type with lamp & 0.3 m lead wire
- 2B* - DIN type with '2 in 1' BUS cable
(Air control v/v + Vacuum release v/v)
- 3B* - DIN type with '3 in 1' BUS cable
(Air control v/v + Vacuum release v/v + Digital switch)

* Can not available with double solenoid valve

※ Remark

CL : Available only with DC24V

3B : Available only with DC24V

Available only with 'S2' or 'S2P', section ⑦

☞ About 'BUS cable' (340, 341)

⑥ Vacuum release flow adjust

- No mark - Standard
- **A** - Attached

⑦ Vacuum switch

- No mark - Vacuum gauge.
- **S2(P)** - Digital display output 2points, No analog supply M8-4Pin Connector type 0.3m lead wire.
- SG2(P) - Digital display output 2 points, No analog supply Grommet type 4-Core 2m lead wire.
- SG3(P) - Digital display output 2 points, Analog supply Grommet type 5-Core 2m lead wire.

※ Remark: ① S..(P)

↳ Output type :PNP open collector

② VCM8 42 : M8-4Pin connector wire.
Only for type S2 or S2(P).

⑧ Non-return valve

- No mark - Standard
- **N** - Non-return valve.

⑨ Sealing

- No mark - Standard
- **V** - Viton[®]
- E** - EPDM

Performance Data

Series	MAX. Vacuum (-kPa)	Feed pressure (MPa)	Vacuum flow, NI/min, at different vacuum level -kPa (-mmHg)									
			0 (0)	10 (75)	20 (150)	30 (225)	40 (300)	50 (375)	60 (450)	70 (525)	80 (600)	90 (675)
VLS	60	0.4	302	176	110	70	46	28	6.8	-	-	-
	70	0.5	344	200	130	82	50	37.5	23	11.3	-	-
	75	0.6	362	194	154	100	52	38	32	22	-	-

Series	Feed pressure (MPa)	Air consumption (NI/min)	Time, s/l, to evacuate a volume to different vacuum level -kPa (-mmHg)								
			10 (75)	20 (150)	30 (225)	40 (300)	50 (375)	60 (450)	70 (525)	80 (600)	90 (675)
VLS	0.4	70	0.028	0.09	0.17	0.29	0.38	0.8	-	-	-
	0.5	85	0.013	0.08	0.15	0.25	0.3	0.4	0.8	-	-
	0.6	104	0.012	0.07	0.12	0.2	0.28	0.36	0.6	-	-

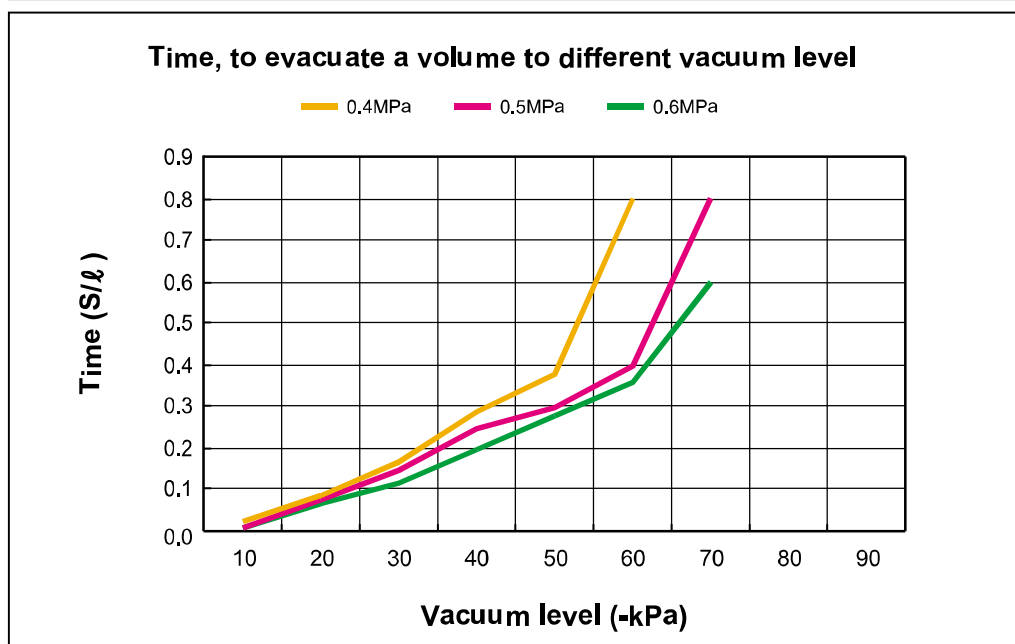
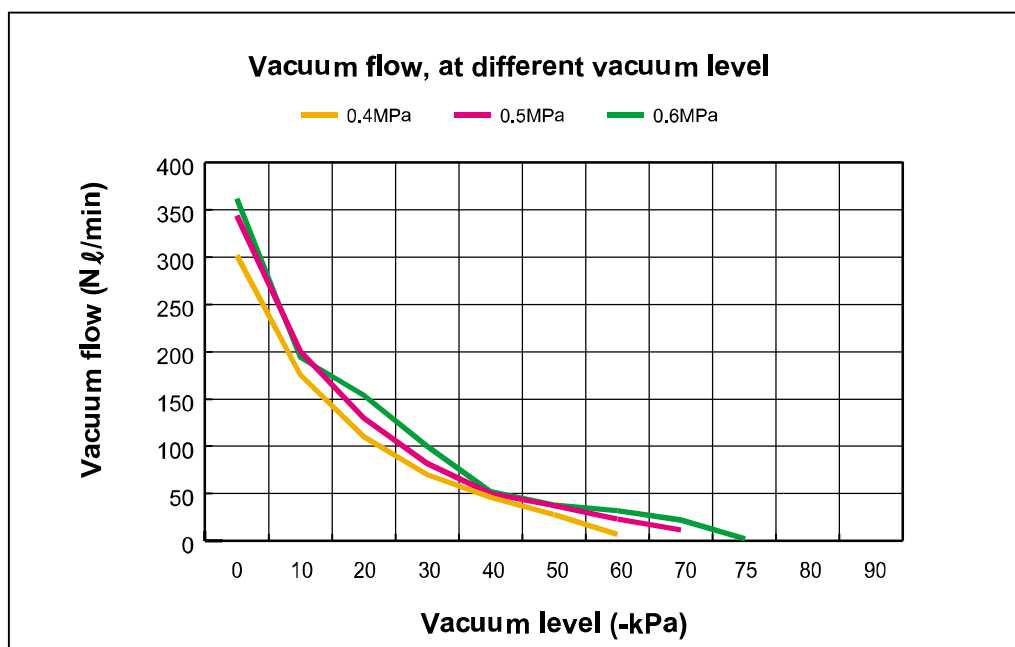

Dimensional Information

With Vacuum control valve, Vacuum release control valve and Digital Vacuum Switch

▼ Series VS 144.. / VLS 144..

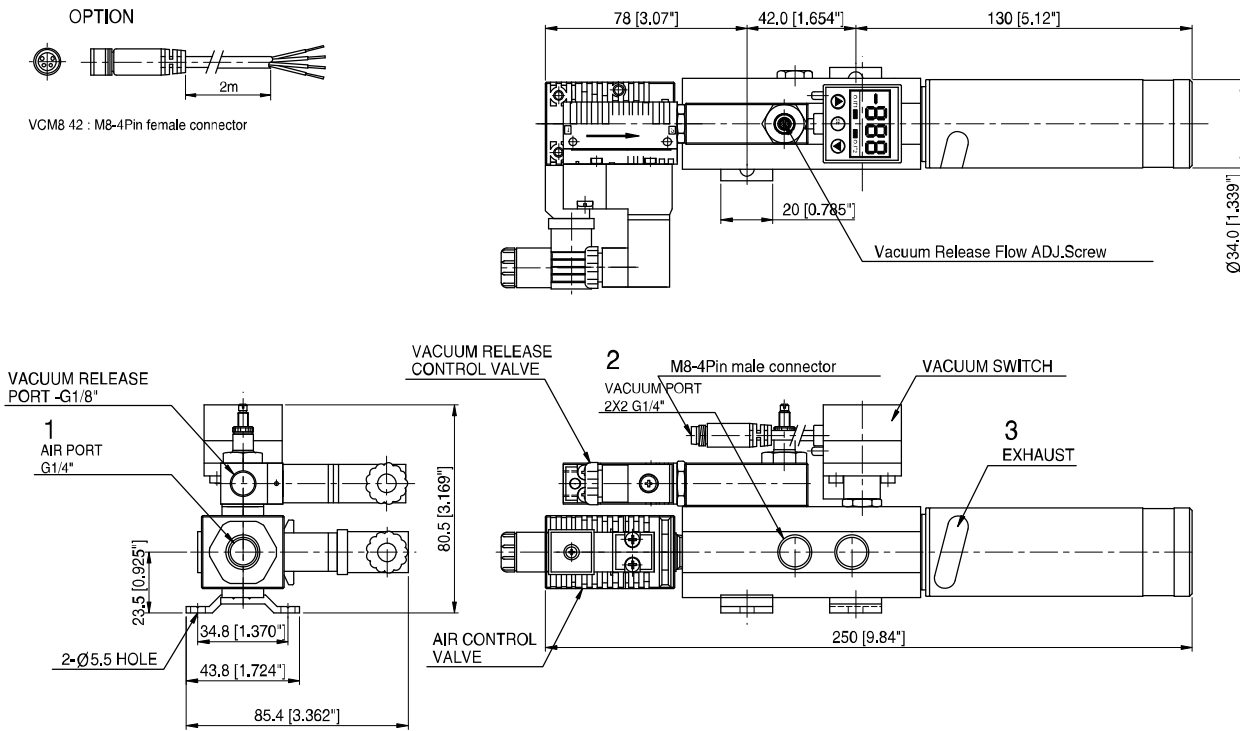

Measure unit : mm [in]

Standard

▼ Series VS 144.. / VLS 144..

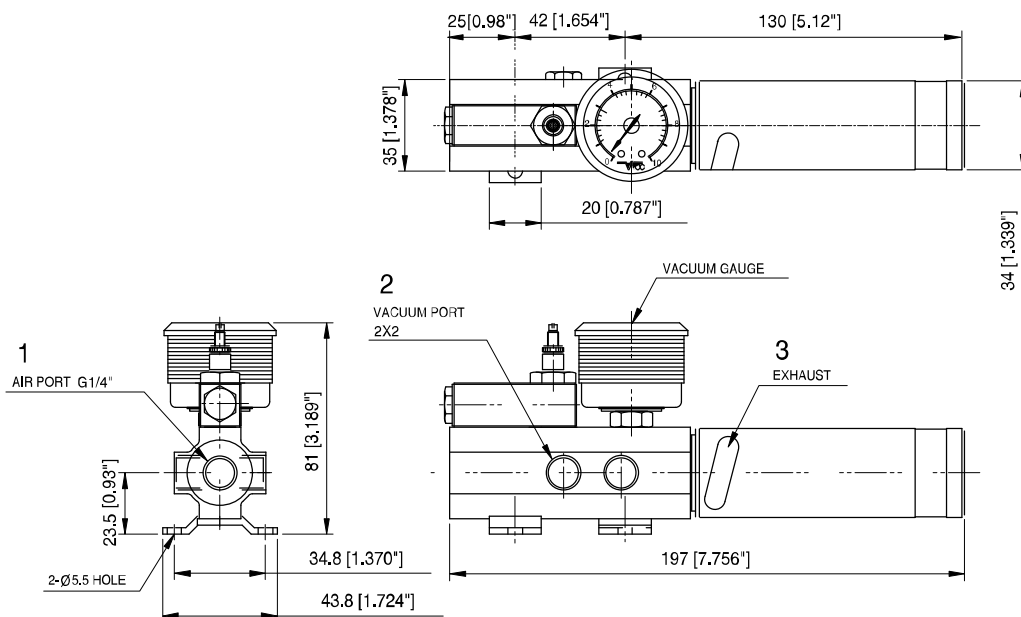

Measure unit : mm [in]

VACUUM PUMPS

Dimensional Information

With Vacuum control valve, Vacuum release control valve and Digital Vacuum Switch

▼ Series VS 146.. / VLS 146..

OPTION

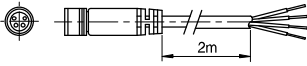

VCMB 42 : M8-4Pin female connector

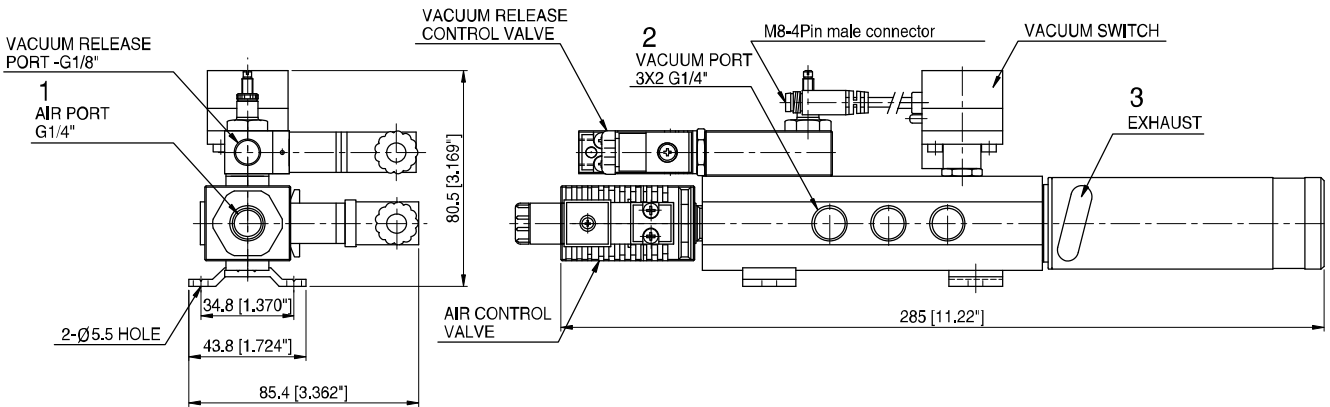
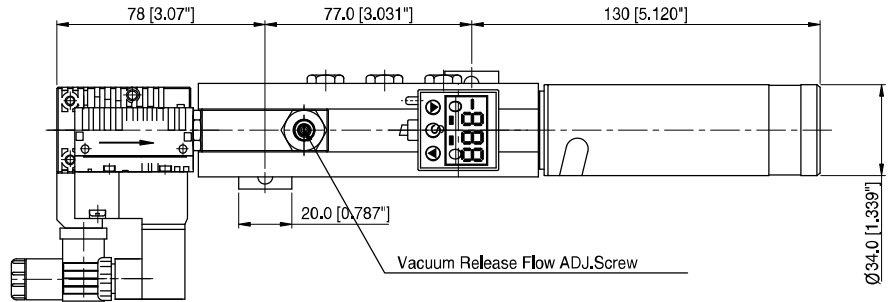

Measure unit : mm [in]

Standard

▼ Series VS 146.. / VLS 146..

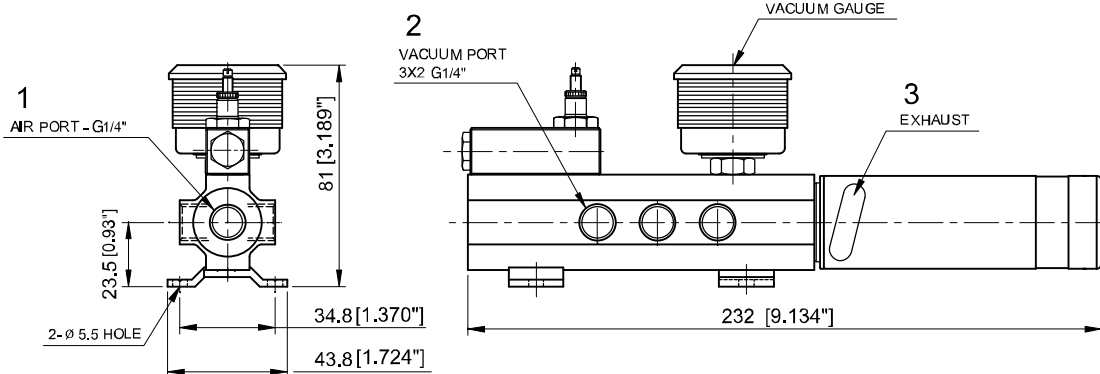
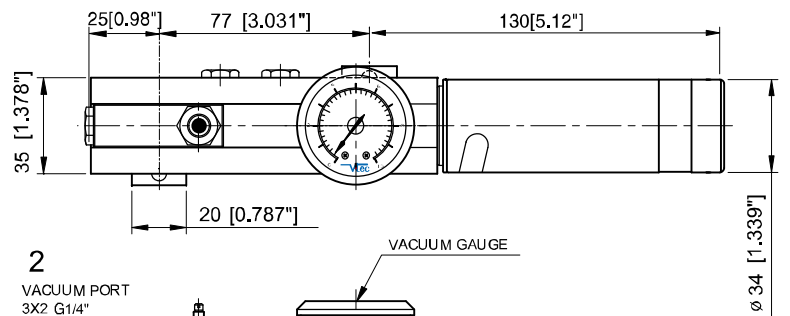

Measure unit : mm [in]



Dimensional Information

With Vacuum control valve, Vacuum release control valve and Digital Vacuum Switch

▼ Series VS 148.. / VLS 148..

OPTION

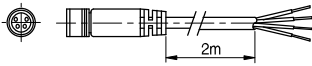

VCM8 42 : M8-4Pin female connector

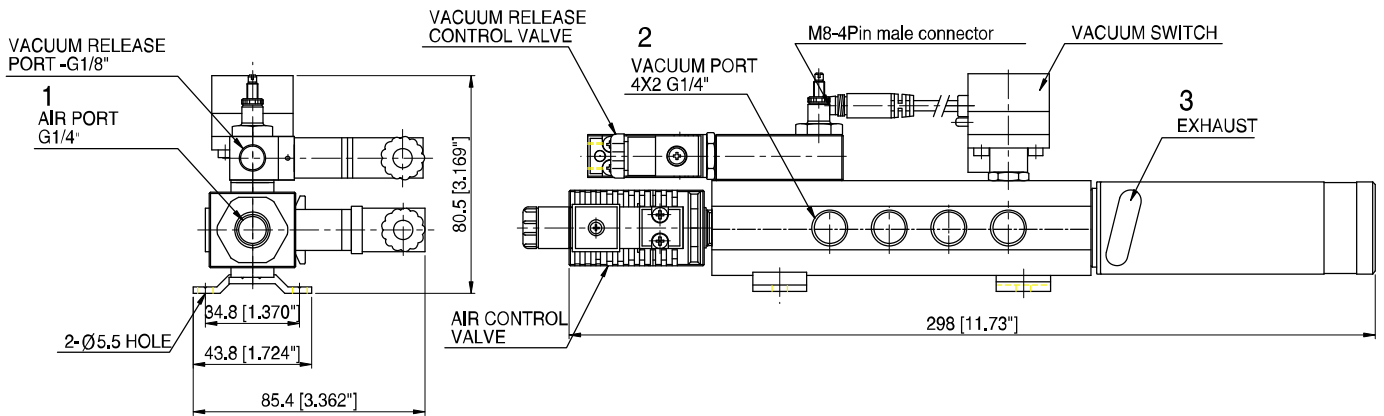
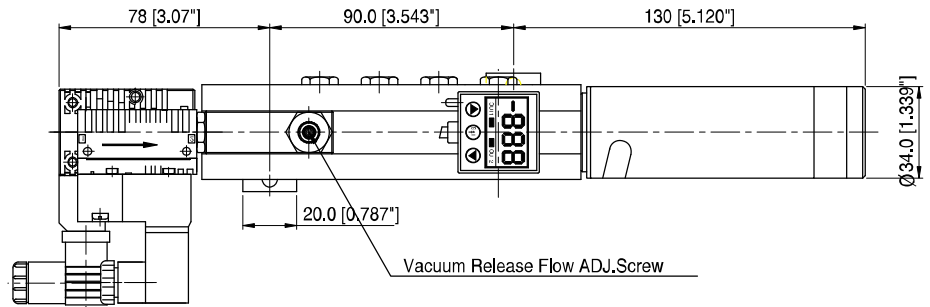

Measure unit : mm [in]

Standard

▼ Series VS 148.. / VLS 148..

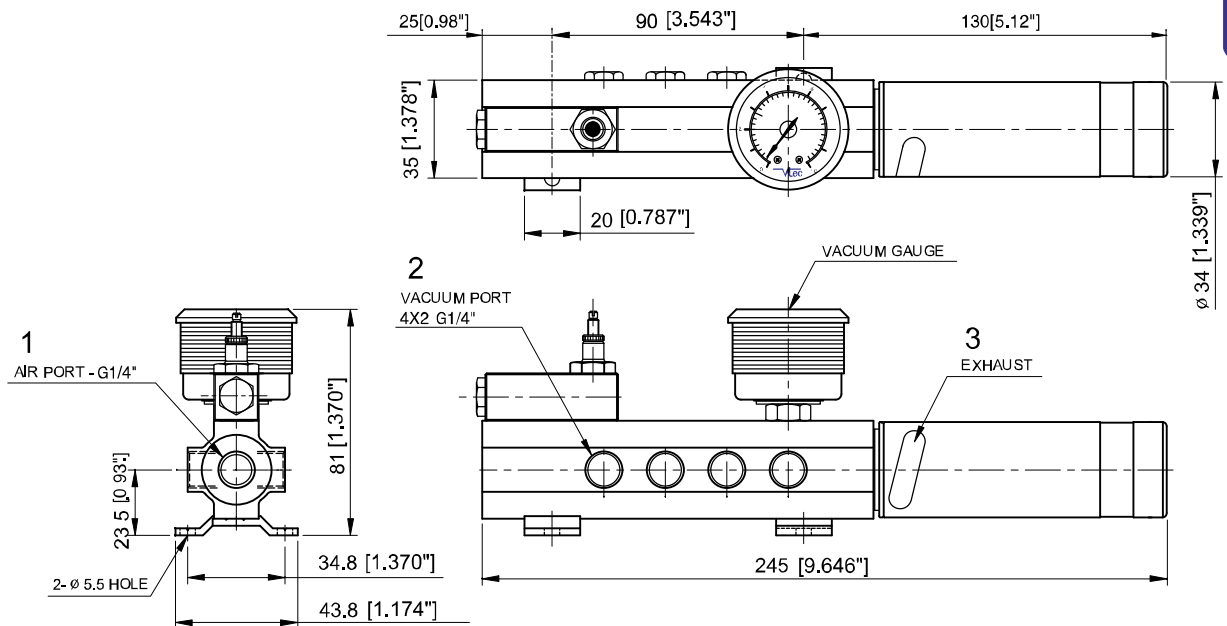

Measure unit : mm [in]

VACUUM PUMPS

