

SPECIAL GRIPPERS / Needle Gripper

Needle Gripper

Features and Strengths

Double-acting pneumatic cylinder for safe handling of work pieces
Variable needle stroke for widely covering applications
Easy operation and maintenance



Examples of use

Textiles, Fleece, Shoes soles, Carpets, Metal foam, Felt
Insulating mats, Foam materials

Specifications

Description	VHN110-12P
Number of needles	12
Needle diameter	1.5 Ø
Stroke	0 ~ 3.5 mm
Operating pressure	3 ~ 6 bar
Operating temperature	5 ~ 60 °C
Weight	500 g
Material of Needles	S45C

Dimensions

[Unit : mm]

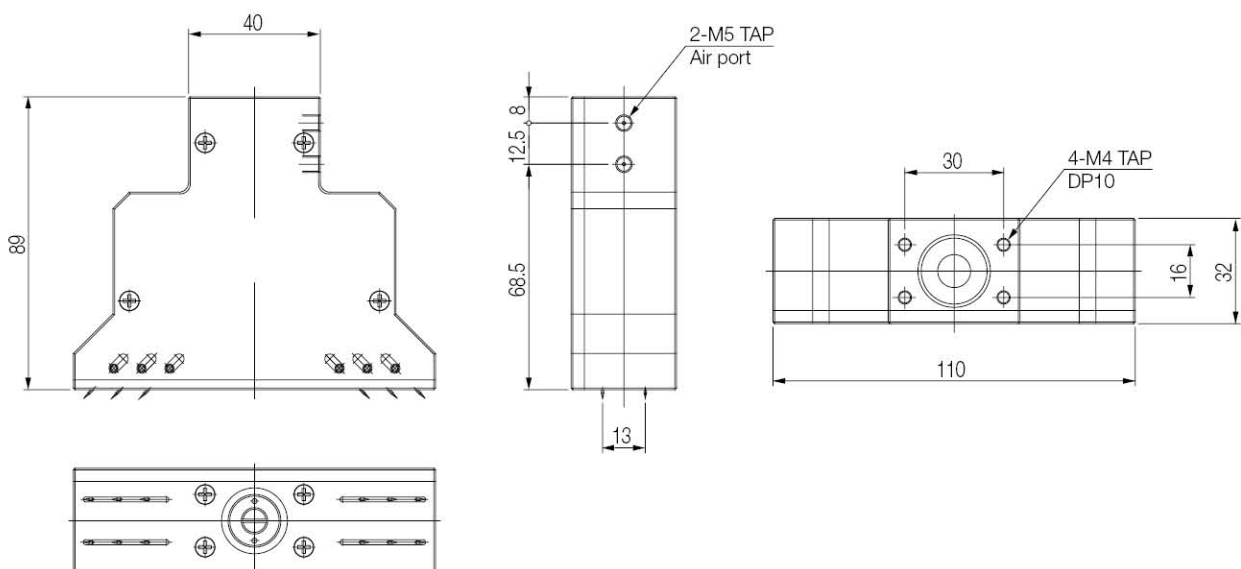

Build an Ordering No.

VHN110-12P

1. Needle Gripper

1. Needle Gripper	Description	Symbol
	Needle Gripper, 110mm size, Aluminum Body, 12 needles, Needle dia. 1.5mm	VHN110-12P

Adjustable needle length

