

VACUUM PUMPS / Micro pumps

MC102

Features and Strengths

- Highly operational reliability despite fluctuating or low compressed-air pressure
- Low energy consumption
- Compact size and light weight
- Push-in type direct hose fitting

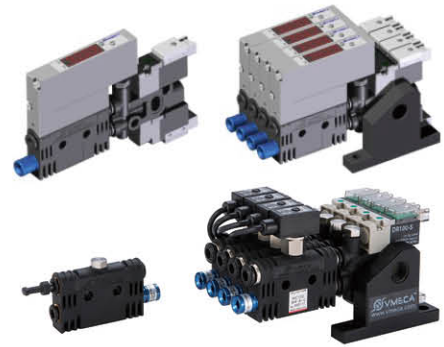

Specifications

Description	MC102
Max. Vacuum level	-83 kPa
Open Vacuum flow	16.5 NI/min
Max. Feed pressure	6 bar
Temperature	-20 ~ 80 °C
Noise level	50 ~ 60 dBA
Weight	0.7 g

Vacuum Flow

Model	Max. vacuum (-kPa)	Feed Pressure (bar)	Vacuum flow (NI/min) at different vacuum levels (-kPa)									
			0	10	20	30	40	50	60	70	80	90
MC102	50	1.2	11.5	6.3	2.2	1.6	0.7	-	-	-	-	-
	83	2.2	14.2	9.4	3.3	2.2	2	1.4	0.8	0.4	0.18	-
	80	2.6	16.5	11.9	5.1	2.3	1.4	1.3	0.9	0.3	0.12	-

Evacuation Time

Model	Feed Pressure (bar)	Air Consumption (NI/min)	Evacuation time in sec / liter to reach different vacuum levels (-kPa)									
			10	20	30	40	50	60	70	80	90	
MC102	1.2	6.8	0.68	3	6.1	11.8	27.2	-	-	-	-	
	2.2	9.6	0.4	1.48	4.3	6.9	9.1	15.3	27.4	50.2	-	
	2.6	10.6	0.34	1.6	3.9	7	10.4	17.5	30.9	61.4	-	

Dimensions – Basic Pump

[Unit : mm]

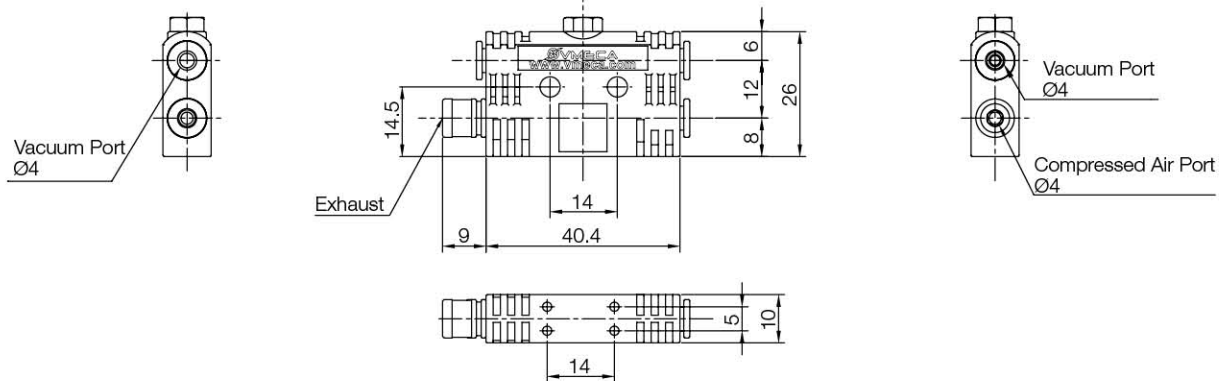

Dimension - with Accessories

[Unit : mm]

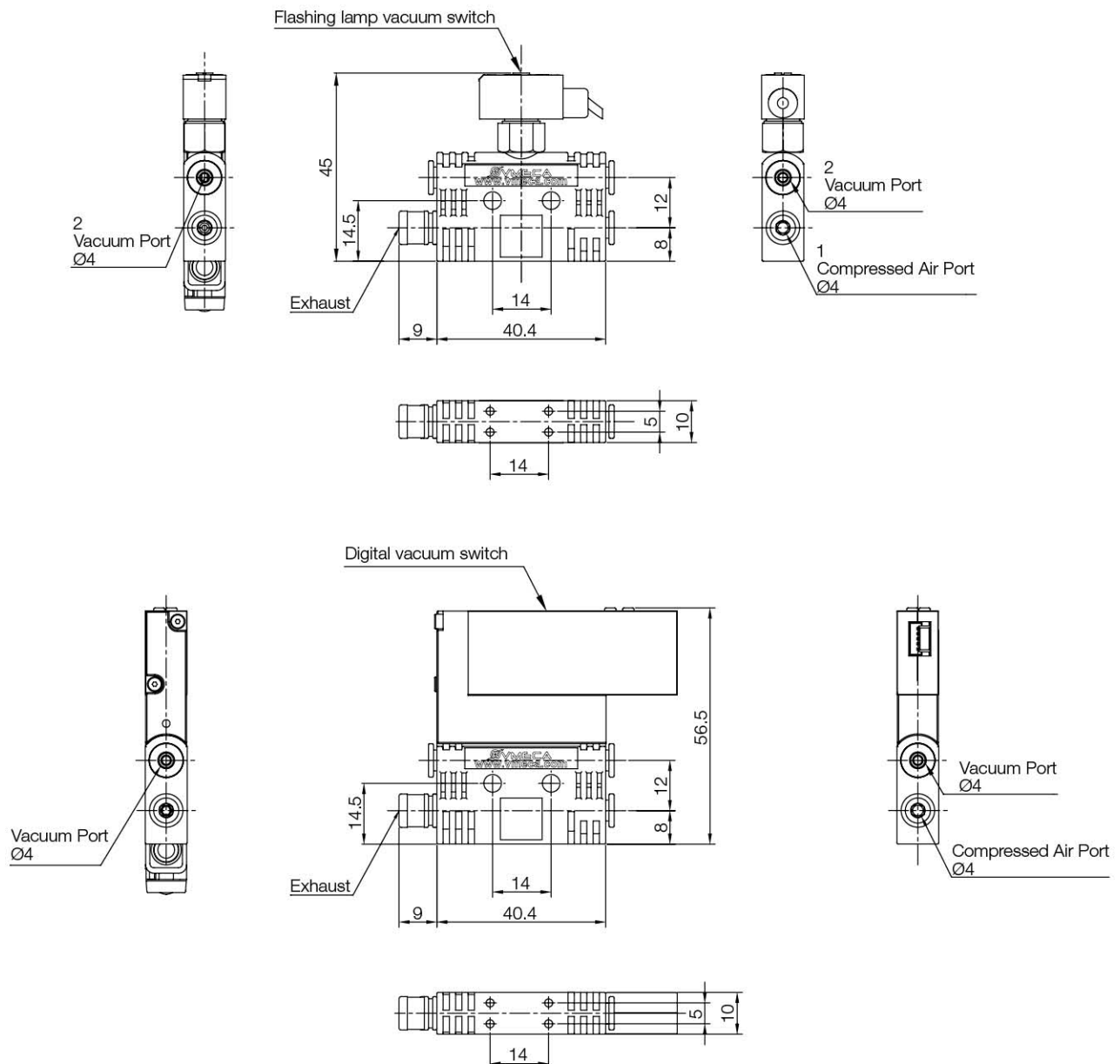

VACUUM PUMPS / Micro pumps - Control unit

Performance data

MC102

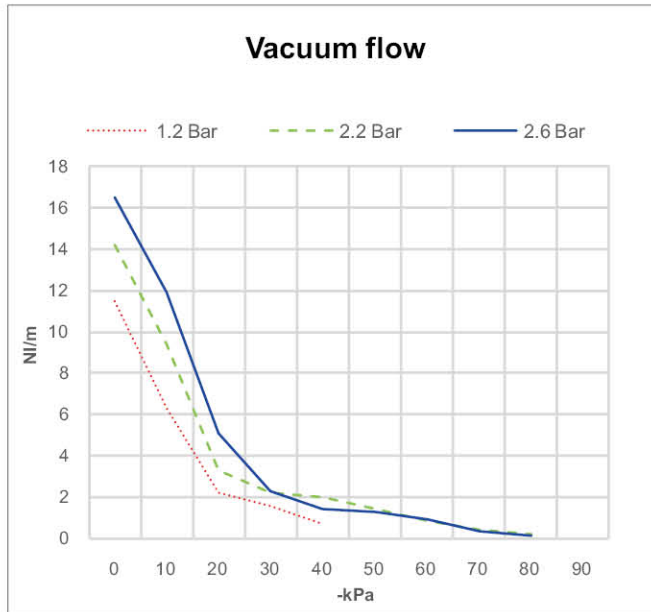

※ Vacuum flow at different vacuum level

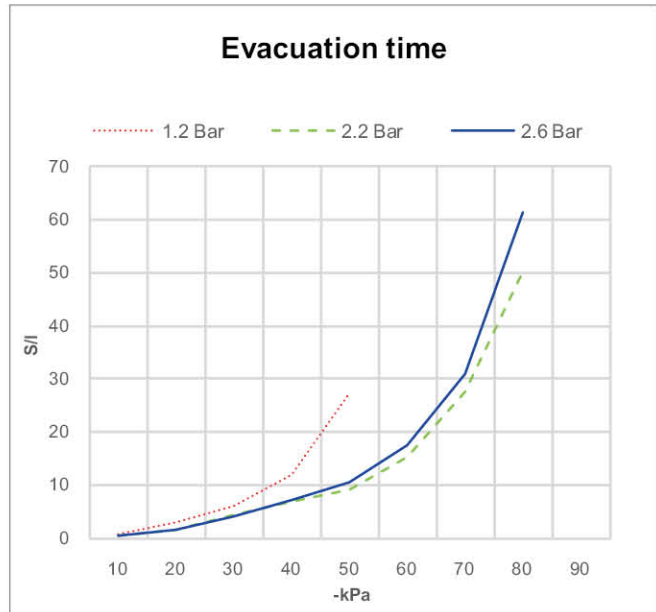

※ Time to evacuate a volume at different vacuum level



I Build an Ordering No.

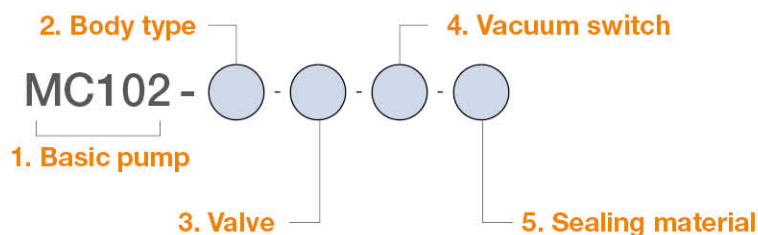

1. Basic pump	Description	Symbol
	Micro pump, 2-stage cartridge, Plug	MC102
2. Body type	Description	Symbol
	Single unit	S
	Manifold unit - 2 stacks	M2
	Manifold unit - 4 stacks	M4
	Manifold unit - 6 stacks	M6
	Manifold unit - 8 stacks	M8
	Manifold unit - 10 stacks	M10
3. Valve	Description	Symbol
	No valves: Only available with Single unit	Blank
	Air control valve : N.C.(Normal Closed) / Vacuum release valve : N.C.(Normal Closed)	A
	Air control valve : N.C.(Normal Closed)	B
	- The valve for Micro pump is available only DC24V	
4. Vacuum switch	Description	Symbol
	No switch	Blank
	LED Vacuum switch, No analog supply, M8-3pins, NPN	C
	LED Vacuum switch, No analog supply, M8-3pins, PNP	PC
	LED Vacuum switch, No analog supply, 3m lead wire, NPN	G
	LED Vacuum switch, No analog supply, 3m lead wire, PNP	PG
	Digital Vacuum switch, analog supply, 0.3M lead wire, NPN	V11N
	Digital Vacuum switch, analog supply, 0.3M lead wire, PNP	V11P
5. Sealing material	Description	Symbol
	NBR	Blank
	VITON	V
	EPDM	E

I Spare Parts – Basic pumps

Part No.	Description	Weight (g)
MC102-S	Micro pump, 2-stage cartridge, Plug, Single unit	14.1

I Spare Parts – Cartridge

Part No.	Description	Weight (g)
VC102	Micro vacuum cartridge, 2-Stage for MC102	0.7

I Spare Parts – Plug

Part No.	Description
VCP-M7	Holding plug for MC102

