

Technische Daten

BAUFORM

4-teilige Körperkonstruktion (verschraubt), mit reduziertem, zylindrischen Durchgang, L- oder T-Bohrung, allseitig dichtend, nicht überschneidungsfrei.

BETÄTIGUNG

90°-Drehung des Handhebels.

ANSCHLUß

Innengewinde 1/2" bis 2", ISO 228.

BETRIEBSDRUCK

Großvakuum bis Nenndruck PN63 (bis +80°C). Für Betriebstemperaturen über +80°C siehe Druck-Temperatur-Diagramm.

TEMPERATUR

-30°C bis max. +180°C

WERKSTOFFE

Gehäuse: Edelstahl 1.4408
Kugel: Edelstahl 1.4401
Kugeldichtung: PTFE mit 15% Glasfaser verstärkt
Spindeldichtung: PTFE - FKM
Handhebel: Edelstahl
Kunststoffummantelt (rot)

ZUSATZAUSSTATTUNG

Pneumatischer oder elektrischer Schwenkantrieb, elektrische Stellungsanzeige.

Alle Angaben sind freibleibend und unverbindlich!

Specification

DESIGN

4-piece design (screwed), reduced cylindrical bore, L- or T-configuration, sealed on all ports, not overlap free.

OPERATION

Rotation of the handle through 90°.

CONNECTION

Female B.S.P. thread 1/2" - 2", ISO 228.

PRESSURE RANGE

Almost vacuum up to nominal pressure PN 63 (up to 80°C). For higher temperatures please refer to the Pressure-Temperature-Diagram.

TEMPERATURE RANGE

-30°C up to +180°C

MATERIALS

Body: Stainless steel 1.4408
Ball: Stainless steel 1.4401
Ball seals: PTFE reinforced with 15% glassfibre
Stem seals: PTFE - FKM
Handle: Stainless steel
plastic coated (red)

OPTIONS

Pneumatic or electric actuator, electrical position indicator

The above information is intended for guidance only and the company reserves the right to change any data herein without prior notice!

Artikel:
PD

3-Wege Kugelhahn
Reduzierter Durchgang
PN 63

Edelstahl

















Type:
PD

3-Way Ball Valve
Reduced bore
PN 63

Stainless Steel



Handhebel- bzw. Antriebs- montage / Handle or actuator mounting	T-Bohrung / T-configuration				L-Bohrung / L-configuration		
	1	2	3	4	5	6	7
Stellung 0° position 0°							
Stellung 90° position 90°							

► **[Contact]**

Airtec Pneumatic Engineering BV
Postbus 234
NL-8160 AE Epe
Nederland

► **[Fon & Web]**

Telefoon: +31 (0)578-627866
Telefax: +31(0)578-627839
http://www.airtec.nl
e-mail: info@airtec.nl

Artikel- u. Bestellungenangaben: z.B. PD311425

= 3-Wege Kugelhahn, Edelstahl / PTFE, mit Handhebel, L-Bohrung, 1"

1.+ 2. Stelle Produkt	3.+ 4. Stelle Werkstoffe Gehäuse/ Dichtung/ Kugel	5. Stelle Betätigung	6. Stelle Kugelbohrung	7.+ 8. Stelle Anschlußgröße (nach ISO 228)
PD= 3-Wege Kugelhahn, reduzierter Durchgang, 4-teilige Ausführung	31 = Edelstahl / PTFE / Edelstahl	1 = mit Handhebel	4 = L-Kugelbohrung 5 = T-Kugelbohrung	23 = 1/2" 24 = 3/4" 25 = 1" 26 = 1 1/4" 27 = 1 1/2" 28 = 2"

Ordering example: e.g. PD311425

= 3-way ball-valve, stainless steel / PTFE / stainless steel, with handle, L-configuration, female B.S.P. thread, 1"

1.+ 2. Digit Product	3.+ 4. Digit Material Body / Seal / Ball	5. Digit Operation	6. Digit Options	7.+ 8. Digit Connection size (acc. to ISO 228)
PD= 3-way ball-valve, reduced bore, 4-piece design	31 = Stainless steel / PTFE / Stainless steel	1 = with Handle	4 = L-configuration 5 = T-configuration	23 = 1/2" 24 = 3/4" 25 = 1" 26 = 1 1/4" 27 = 1 1/2" 28 = 2"

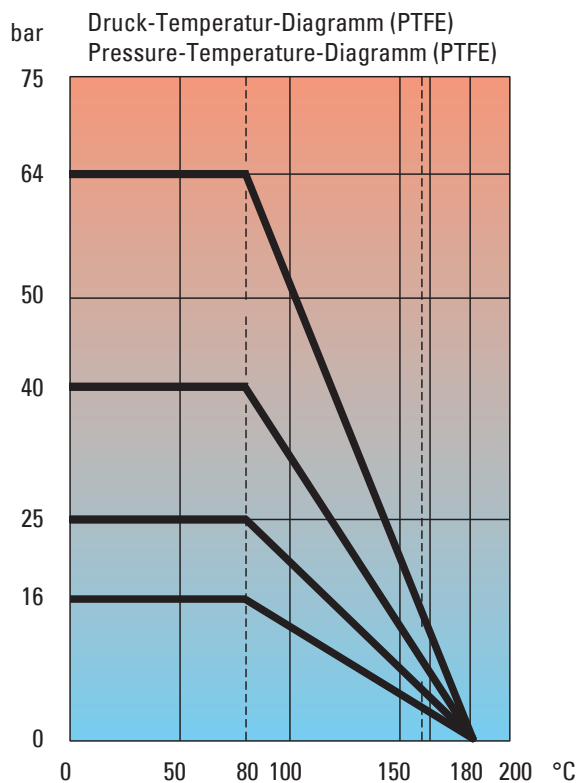
**Hinweis**

Bei den in dieser Dokumentation beschriebenen Produkten, in der von uns gelieferten Form, handelt es sich weder um Maschinen gemäß Artikel 2 Absatz a noch um unvollständige Maschinen gemäß Artikel 2 Absatz g im Sinne der Richtlinie 2006/42/EG über Maschinen.

Advice

The products described in this documentation in the conditions of our delivery are no machinery according to annex 2 paragraph a respectively no partly completed machinery according to annex 2 paragraph g of the directive 2006/42/EC on machinery.

▶ **[Contact]**

Airtec Pneumatic Engineering BV
Postbus 234
NL-8160 AE Epe
Nederland

▶ **[Fon & Web]**

Telefoon: +31 (0)578-627866
Telefax: +31(0)578-627839
<http://www.airtec.nl>
e-mail: info@airtec.nl

Stückliste / Parts list

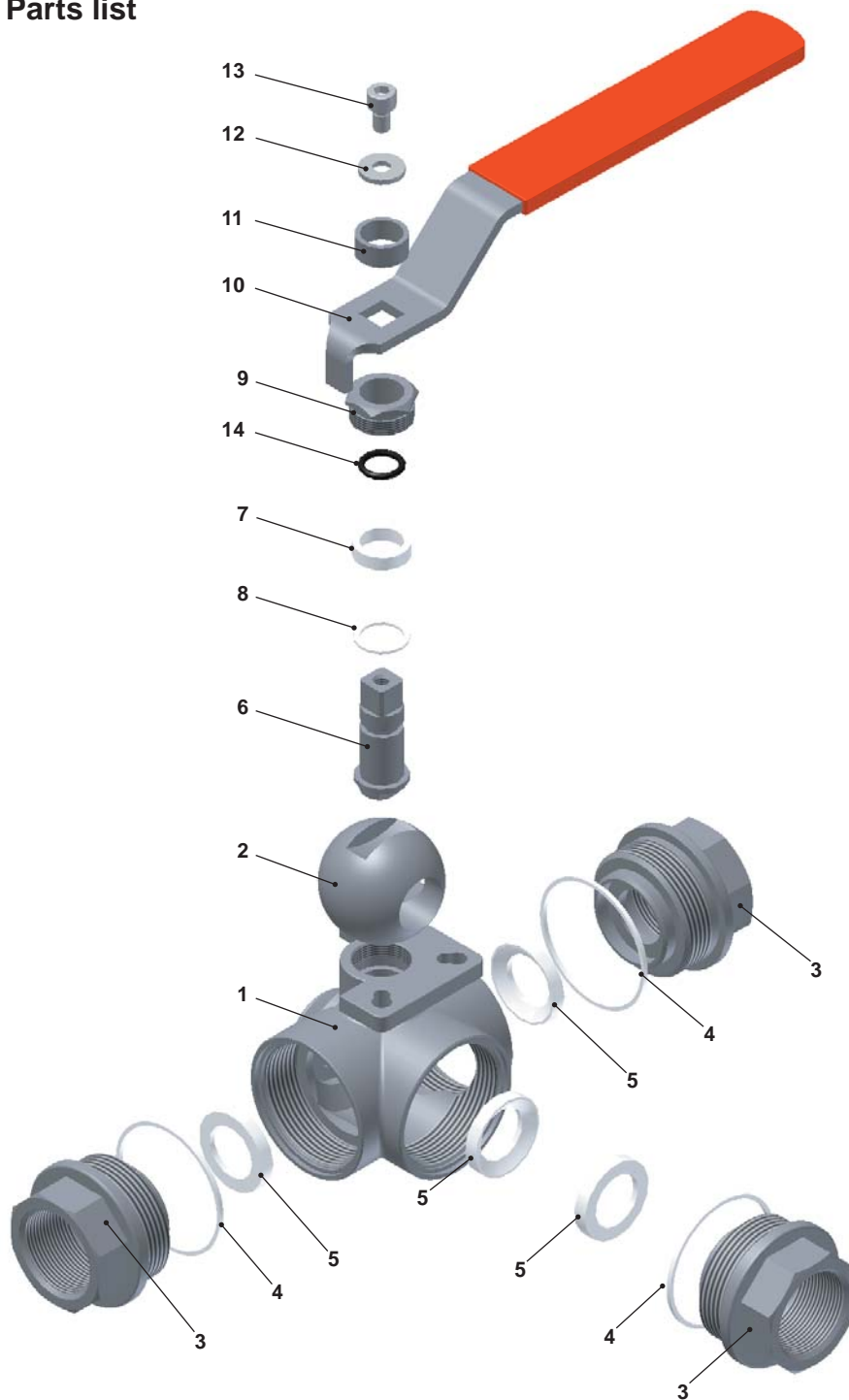

Pos.	Bezeichnung / Description		Material / Material	
1	Gehäuse	Body	Edelstahl 1.4408	Stainless steel 1.4408 (AISI 316)
2	Kugel	Ball	Edelstahl 1.4401	Stainless steel 1.4401 (AISI 316)
3	Anschlußende	Connection end	Edelstahl 1.4408	Stainless steel 1.4408 (AISI 316)
4	Gehäusedichtung	Body seals	PTFE	PTFE
5	Kugeldichtung	Ball seals	PTFE mit 15% Glasfaser verstärkt	PTFE reinforced with 15% glassfibre
6	Spindel	Stem	Edelstahl 1.4401	Stainless steel 1.4401 (AISI 316)
7	Spindeldichtung	Stem seals	PTFE	PTFE
8	Spindelscheibe	Stem washer	PTFE mit 15% Glasfaser verstärkt	PTFE reinforced with 15% glassfibre
9	Packungsmutter	Packing nut	Edelstahl	Stainless steel
10	Handhebel	Handle	Edelstahl	Stainless steel
11	Hülse	Wascher	Edelstahl	Stainless steel
12	Scheibe	Disk	Edelstahl	Stainless steel
13	Innensechskantschraube	Allen screw	Edelstahl	Stainless steel
14	O- Ring	o- ring	FKM	FKM

Dok-Nr.: KAT-PD-3/4 26.04.04 - Änderung: Werkstoff Kugeldichtung; Maß T

► **[Contact]**
 Airtec Pneumatic Engineering BV
 Postbus 234
 NL-8160 AE Epe
 Nederland

► **[Fon & Web]**
 Telefoon: +31 (0)578-627866
 Telefax: +31(0)578-627839
<http://www.airtec.nl>
 e-mail: info@airtec.nl

Abmessungen / Dimension

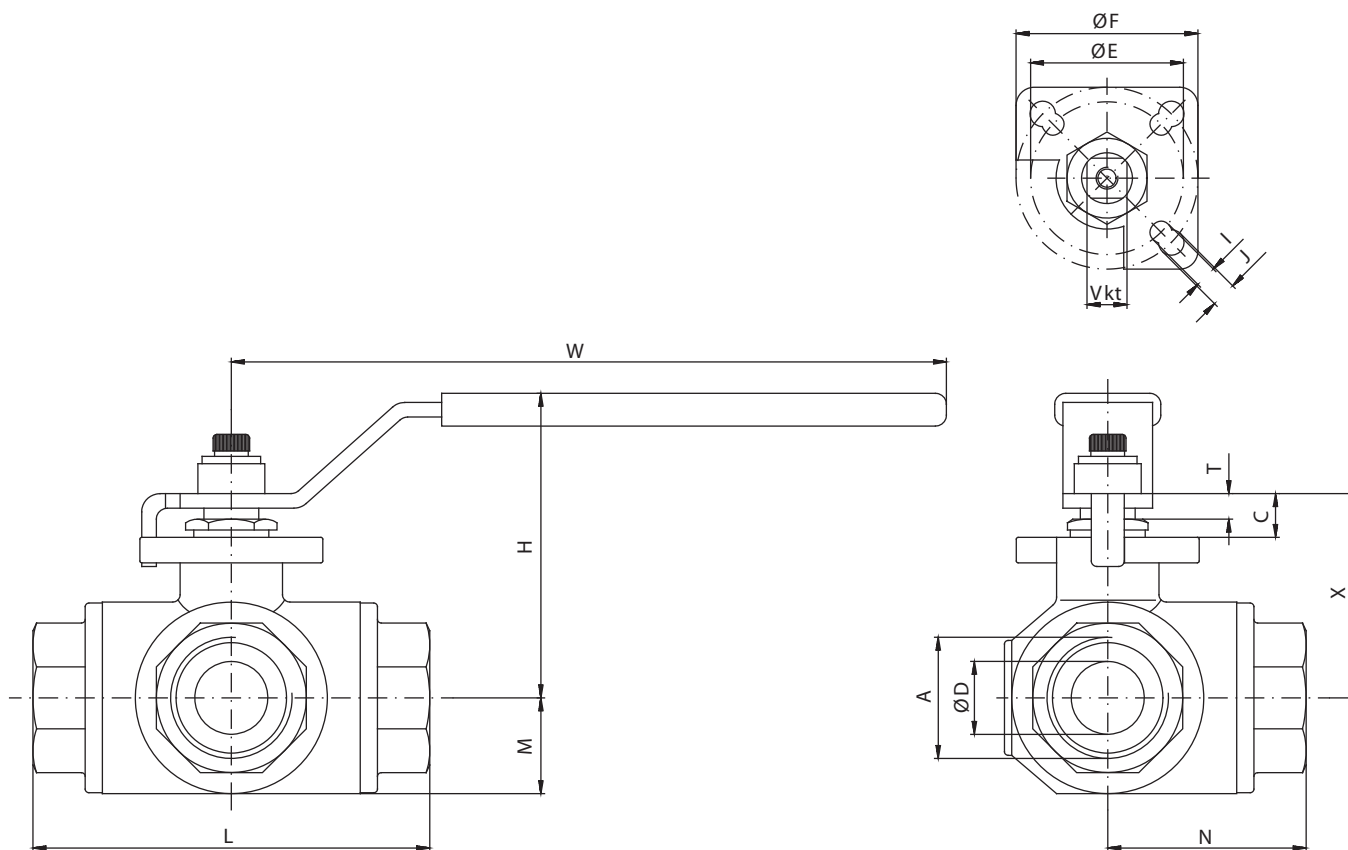

A	ØD	L	N	M	H	X	C	T	ØE	ØF	Vkt	I	J	W	kg
1/2	11	79	39,5	18,5	65,5	41	10,5	6	36	42	9	-	4 x Ø6	160	0,73
3/4	16	87	43,5	22,5	80	53	13	7	42	50	11	4 x Ø6	4 x Ø6	190	1,11
1	20	108	54	26	82,5	56	12	7	42	50	11	4 x Ø6	4 x Ø6	190	1,63
1 1/4	25	124	62	33,5	94,5	68	12,5	7	42	50	11	4 x Ø6	4 x Ø6	190	2,55
1 1/2	32	134	67	37,5	119	78	17	8	50	70	14	4 x Ø7	4 x Ø9	240	3,74
2	40	164	82	48	121	86	16	8	50	70	14	4 x Ø7	4 x Ø9	240	6,25

► **[Contact]**
 Airtec Pneumatic Engineering BV
 Postbus 234
 NL-8160 AE Epe
 Nederland

► **[Fon & Web]**
 Telefoon: +31 (0)578-627866
 Telefax: +31(0)578-627839
<http://www.airtec.nl>
 e-mail: info@airtec.nl