



3/2-way solenoid valve

NC - Valve normally closed (as standard)

NO - Valve normally open (as option)

UN - Universal design (as option)

Direct operated valve.

No differential pressure is necessary for operation. When energized, the valve seat is opened directly.

In standard (NC) the valve closes with spring power.

■ Solenoid valve for high pressure applications

## TECHNICAL SPECIFICATIONS

Type of control	Direct operated valve, no pressure difference required
Design	Piston design
Connection	Sleeve connection G1/4 DIN ISO 228/1 (BSP) <small>Further connections like NPT on request</small>
Installation	Actuator upright
Pressure	0 - 300 bar (see table on page 2)
Medium	Clean, neutral gaseous and liquid media
Max. viscosity	22 mm <sup>2</sup> /s
Temperature range	Medium: -30 °C / +80 °C Environment: -30 °C / +50 °C <small>Taking into account other influencing parameters</small>
Body material	Brass 2.0401, 2.0402 Stainless steel 1.4301, 1.4404
Metallic inner parts	Brass and st. steel
Sealing	PTFE, PEEK
Supply voltage	AC~ 24V, 110V, 230V DC= 12V, 24V <small>Other supply voltages on request</small>
Voltage tolerance	-10% / +10%
Power consumption	.802 = 24 Watt .808 = 10 Watt ⚠ .322 = 30 Watt .242 = 46 Watt .248 = 30 Watt ⚠
Protection class	IP65 according to DIN 60529
Duty factor	100% ED-VDE 0580
Connection type	Device plug DIN 43650, terminal box
Ex-proof	acc. to 2014/34/EU (ATEX)

## VALVE FEATURES

- For high pressure applications up to 300 bar
- No pressure difference required
- High life time
- High-quality materials
- Reliable and sturdy sealing elements

## FUNCTION

NC – non energized closed

NO – non-energized open

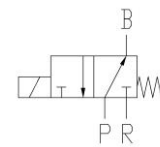
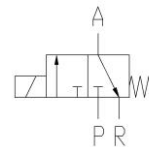

## CONNECTION DIAGRAM

For AC/DC coils

For DC coils  
w/ integr. rectifier

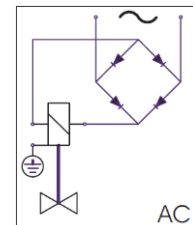
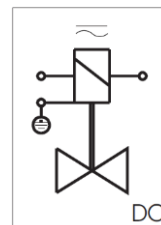

## CERTIFICATES



# TECHNICAL FEATURES

Seat Ø mm	Kv-value m³/h	Standard type	max. pressure for coils			max. pressure for coils ATEX	
			.802	.322	.242	.808	.248
1,0	0,06	.7540/.../	0-100	0-160	0-300	0-100	0-200
1,5	0,09	.7541/.../	0-75	0-130	0-280	0-75	0-150
2,0	0,13	.7542/.../	0-45	0-100	0-250	0-45	0-180
2,5	0,16	.7543/.../	0-28	0-75	0-200	0-28	0-115
3,0	0,20	.7544/..04/	0-20	0-60	0-150	0-20	0-90
4,0	0,35	.7545/..04/	0-16	0-30	0-85	0-12	0-60
5,0	0,50	.7546/..04/	0-16	0-20	0-55	0-10	0-38

# DIMENSIONS

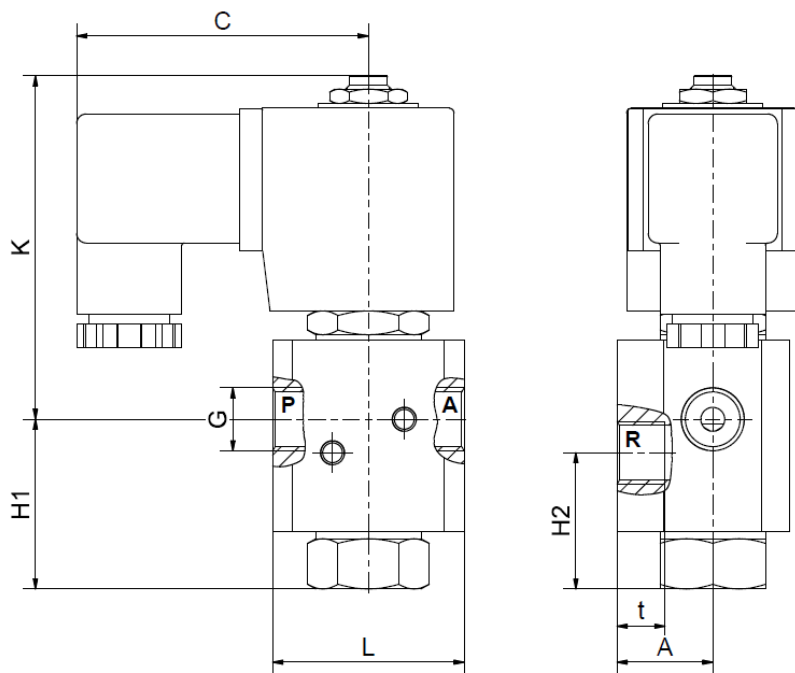

Coil	.802 / .808*	.322	.242 / .248
Type	.7540-46/..04/	.7540-46/..04/	.7540-46/..04/
G	1/4	1/4	1/4
A	25	25	30
C	70	77	93
H1	35,5	35,5	45
H2	28,5	28,5	38
K	90	122	142
L	50	50	60
t	9	9	12
kg	1,5	2,1	4,7

\*Differing dimension "C" for ATEX coils



## INFORMATION

- It is imperative to observe the installation and safety instructions in our operating and service manuals.
- Required ordering information: valve type, function NC/NO, pressure range, connection, nominal width, medium, flow rate, medium and ambient temperatures, connection voltage.
- **For information on the heating and performance of solenoid coils, refer to the corresponding "Coils" data sheet.**
- **Detailed production-specific drawings and other technical information will be made available when an order is placed.**

## PLEASE NOTE

Each individual application decides which valve type is required, the main factor being the resistance of the materials to the operating medium. The correct selection of materials requires knowledge of the concentration, temperature and degree of contamination of the medium. Other criteria include the operating pressure and max. volumetric flow, since, in addition to high temperatures, high pressures and high flow rates must also be taken into account when selecting the materials.

**All materials used for our valves, be it housing, seals or magnets, will be carefully selected in view of the different application areas. Any information given is non-binding and serves for orientation only. No claims under warranty can be derived therefrom.**

## ORDERING CODE

Type	Connection		Body	Sealing		Coil			Option	
<b>. 7 5</b>	<b>4 0</b>	<b>/</b>	<b>1 0</b>	<b>0 4</b>	<b>/</b>	<b>.</b>	<b>3 2</b>	<b>2</b>	<b>-</b>	<b>X X</b>

4 .	G 1/4
. 0	1.0 mm
. 1	1.5 mm
. 2	2.0 mm
. 3	2.5 mm
. 4	3.0 mm
. 5	4.0 mm
. 6	5.0 mm

06	St.steel 1.4301	80	24 W	2	Standard IP65
10	Brass 2.0402	32	30 W	8	2014/34/EU (ATEX)
13	St.steel 1.4404 *	24	46 W		

04	PTFE
15	PEEK

NO	normally open
1W	Hydrogen

\* only in conjunction with option 1W for hydrogen applications.