



2/2-way pressure controlled valve

NC - Valve normally closed (as standard)

NO - Valve normally open (as option)

DW - Valve with double acting actuator (as option)

Direct pressure controlled valve.

The valve seat is opened against a spring force via the control medium.

In standard (NC) the valve closes with spring power.

■ Valve for clean, gaseous and liquid media

TECHNICAL SPECIFICATIONS

Type of control	Direct pressure operated
Design	Poppet design
Connection	Sleeve connection G1/2 - G 3 <small>Further connections like NPT on request</small>
Installation	Actuator upright or lateral
Pressure	0 - 40 bar (see table on page 2)
Medium	Clean, neutral gaseous and liquid media
Max. viscosity	600 mm ² /s
Temperature range	Medium: -40 °C / +200 °C Environment: -10 °C / +60 °C <small>Depending on the sealing material</small>
Body material	Red brass RG5 / Brass 2.0402 Stainless steel 1.4408
Metallic inner parts	Red brass / Brass and Stainless steel
Sealing	NBR, FKM, EPDM, PTFE
Pilot pressure	4 - 10 bar <small>Observe deviating specifications on the type plate!</small>
Pilot medium	Clean, neutral gaseous
Pilot valve	2/131-31-1702-C182



3/2-way direct operated, NC
G1/8, orifice 1.5mm, 0-8 bar
Aluminum / Stainless steel / FKM
with Cnomo-coil as well as with
integrated screw connection for
easy assembly

Pilot valve

A7231/1002/....



3/2-way direct operated, NC
G1/8, orifice 1.5mm, 0-8 bar
brass / st. steel / FKM

VALVE FEATURES

- No pressure difference required
- High life time
- High-quality materials
- Reliable and sturdy sealing elements
- Long-term availability of spare parts
- NO - non-pressurized open as option
- DW - double acting as option

FUNCTION

NC – non
pressurized
closed

NO – non
pressurized open

DW - double
acting

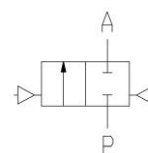
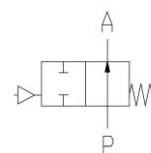
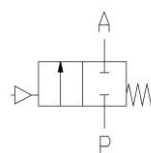

CERTIFICATES



Special design available for temperature ranges **-40 °C up to +300 °C** and **+160 °C** ambient.

Specification and drawings on request.

TECHNICAL FEATURES

				max. pressure with actuator					
G	Seat Ø mm	Kv-value m³/h	Standard type	7.05		7.08		7.13	
				RG5	St.steel	RG5 Brass	St.steel	RG5 Brass	St.steel
1/2	12,5	4,6	.6323/..01(04)/7...	0-16	0-40 *	-	-	-	-
3/4	16	6,4	.6324/..01(04)/7...	0-16	0-20	-	0-40	-	-
1	23	12,5	.6325/..01(04)/7...	0-16	0-16	0-16	0-25	-	0-40
1 1/4	29	21,5	.6326/..01(04)/7...	0-10	0-9	0-16	0-25	-	0-40
1 1/2	35	27,0	.6327/..01(04)/7...	0-8	0-7	0-16	0-20	0-16	0-40
2	43	45,0	.6328/..01(04)/7...	0-4	0-4	0-16	0-12	0-16	0-20
2 1/2	63	82,0	.6329/..01(04)/7...	-	-	0-6	0-5	0-10	0-10
3	76	125,0	.6330/..01(04)/7...	-	-	0-4	0-4	0-10	0-10

				Max. pressure for version closing against the media pressure					
G	Seat Ø mm	Kv-value m³/h	Standard type	7.15		7.58		7.63	
				RG5	St.steel	RG5 Brass	St.steel	RG5 Brass	St.steel
1/2	12,5	4,6	.6323/..01(04)/7...	0-16	0-40 *	-	-	-	-
3/4	16	6,4	.6324/..01(04)/7...	0-16	0-20	-	0-40	-	-
1	23	12,5	.6325/..01(04)/7...	0-10	0-10	0-16	0-22	-	0-40
1 1/4	29	21,5	.6326/..01(04)/7...	0-7	0-7	0-12	0-10	0-16	0-40
1 1/2	35	27,0	.6327/..01(04)/7...	0-6	0-6	0-8	0-8	0-16	0-30
2	43	45,0	.6328/..01(04)/7...	0-3	0-3	0-5	0-5	0-16	0-20
2 1/2	63	82,0	.6329/..01(04)/7...	-	-	0-1	0-1	0-8,5	0-8,5
3	76	125,0	.6330/..01(04)/7...	-	-	0-0,7	0-0,7	0-5	0-6

Values in brackets refer to the standard sealing material for stainless steel version. Pressure data valid at minimum 6 bar control pressure. * At operating pressures above 20 bar, the control pressure must be regulated by means of a throttle: Flow rate 36 - 40 l/min at 6 bar and 20°C

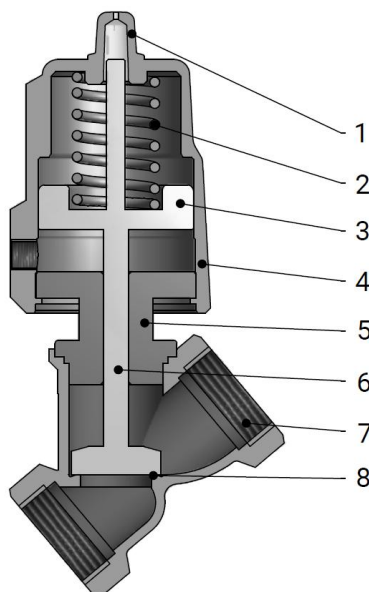

Description	
1	Position indicator
2	Spring
3	Piston
4	Cylinder
5	Screw joint
6	Spindle
7	Valve body
8	Valve seat



DIMENSIONS

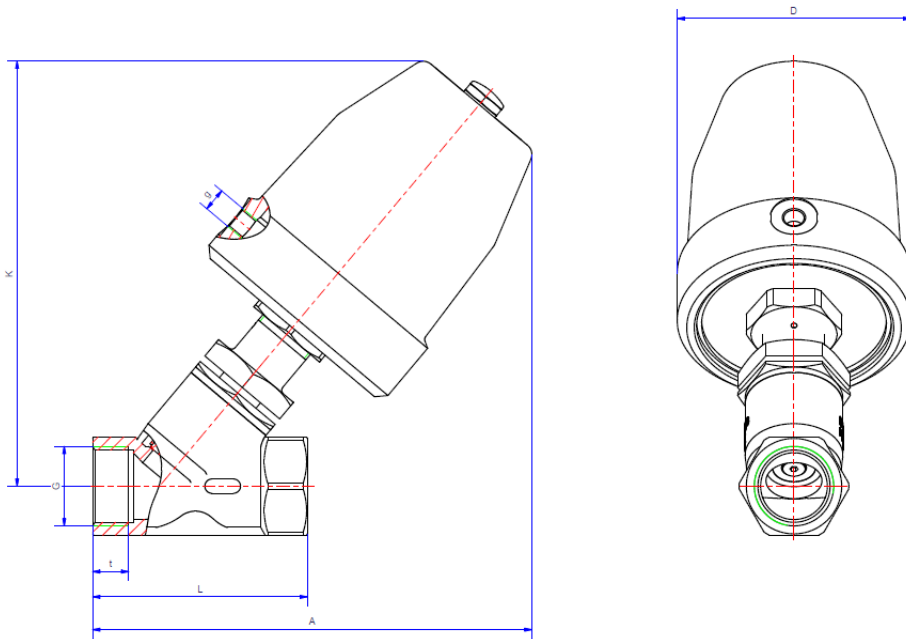

Actuator	7.05						7.08		
Type	6323	6324	6325	6326	6327	6328	6324	6325	6326
G	1/2	3/4	1	1 1/4	1 1/2	2	3/4	1	1 1/4
A	123	130	133	153	162	171	174	175	185
D	62	62	62	62	62	62	94	94	94
K	113	118	122	139	146	155	170	168	174
L	66	75	80	97	107	124	75	80	97
	(65)	(75)	(90)	(110)	(120)	(150)	(75)	(90)	(110)
g	1/8	1/8	1/8	1/8	1/8	1/8	1/8	1/8	1/8
t	13 (12)	15 (13)	11 (15)	13 (17)	15 (19)	17 (21)	15 (13)	11 (15)	13 (17)
kg	1,3	1,4	1,5	2,0	2,3	3,0	1,6	1,8	2,2

The values in brackets apply to the stainless steel version.

Actuator	7.08				7.13					
Type	6327	6328	6329	6330	6325	6326	6327	6328	6329	6330
G	1 1/2	2	2 1/2	3	1	1 1/4	1 1/2	2	2 1/2	3
A	192	203	247	265	240	250	255	261	307	325
D	94	94	94	94	140	140	140	140	140	140
K	181	190	205	211	239	245	250	254	267	273
L	107	124	178	195	80	97	107	124	178	195
	(120)	(150)			(90)	(110)	(120)	(150)		
g	1/8	1/8	1/8	1/8	1/4	1/4	1/4	1/4	1/4	1/4
t	15 (19)	17 (21)	28	28	11 (15)	13 (17)	15 (19)	17 (21)	28	28
kg	2,5	3,3	5,5	7,0	4,5	4,8	4,5	5	7,4	9,0

The values in brackets apply to the stainless steel version.



INFORMATION

- It is imperative to observe the installation and safety instructions in our operating and service manuals.
- Required ordering information: valve type, function NC/NO, pressure range, connection, nominal width, medium, flow rate, medium and ambient temperatures, connection voltage.
- **For information on the heating and performance of solenoid coils, refer to the corresponding "Coils" data sheet.**
- **Detailed production-specific drawings and other technical information will be made available when an order is placed.**

PLEASE NOTE

Each individual application decides which valve type is required, the main factor being the resistance of the materials to the operating medium. The correct selection of materials requires knowledge of the concentration, temperature and degree of contamination of the medium. Other criteria include the operating pressure and max. volumetric flow, since, in addition to high temperatures, high pressures and high flow rates must also be taken into account when selecting the materials.

All materials used for our valves, be it housing, seals or magnets, will be carefully selected in view of the different application areas. Any information given is non-binding and serves for orientation only. No claims under warranty can be derived therefrom.

ORDERING CODE

Type	Connection	Body	Sealing	Actuator		Option	
. 6 3 2/977	2 3	1 1	0 1	7 1	0 5	X X	
23	G 1/2	08	St. steel 1.4408	7 .	Closed wo/ press.	HA	manual override
24	G 3/4	10	Brass 2.0402	8 .	Open wo/ press.	AS	weld-on
25	G 1	11	Red brass RG5	9 .	double-acting		
26	G 5/4			. 0	straight seat.-Actuat.		
27	G 6/4	01	NBR	. 1	Standard-Actuat.		
28	G 2	02	FKM	. 3	Actuat.-St. steel		
29	G 2 1/2	04	PTFE	. 5	Actuator-nickel-pl.		
30	G 3	06	EPDM	. 5	50 mm		
				. 8	80 mm		
				. 3	125 mm		

 **2/977: ATEX acc. to 20/14/34EU // PTB 04 ATEX D 042 // II 2G Ex h IIC T6...T3 Gb X // II 2D Ex h IIIC T80°C...195°C Db X**