



2/2-way solenoid valve

NC - Valve normally closed (as standard)

NO - Valve normally open (as option)

Direct operated valve.

No differential pressure is necessary for operation. When energized, the valve seat is opened directly.

In standard (NC) the valve closes with spring power.

■ Solenoid valve for high pressure applications

TECHNICAL SPECIFICATIONS

Type of control	Direct operated valve, no pressure difference required
Design	Piston design
Connection	Sleeve connection G1/4 DIN ISO 228/1 (BSP) <small>Further connections like NPT on request</small>
Installation	Actuator upright or lateral
Pressure	0 - 900 bar (see table on page 2)
Medium	Clean, neutral gaseous and liquid media
Max. viscosity	22 mm ² /s
Temperature range	Medium: -40 °C / +80 °C Environment: -40 °C (-20 °C)* / +50 °C <small>* for hydrogen applications with option 1W Taking into account other influencing parameters</small>
Body material	Brass 2.0401 Stainless steel 1.4301, 1.4404, 1.4571
Metallic inner parts	Stainless steel
Sealing	PTFE, PEEK, TPE
Supply voltage	AC~ 24V, 110V, 230V DC= 12V, 24V <small>Other supply voltages on request</small>
Voltage tolerance	-10% / +10%
Power consumption	.032 = 11 Watt .148 = 10 Watt ⚡ .012 = 18 Watt .702 = 25 Watt .802 = 24 Watt .808 = 24 Watt ⚡ .322 = 30 Watt .328 = 24 Watt ⚡ .242 = 46 Watt .248 = 30 Watt ⚡
Protection class	IP65 according to DIN 60529
Duty factor	100% ED-VDE 0580
Connection type	Device plug DIN 43650, terminal box
Ex-proof	acc. to 2014/34/EG (ATEX)

VALVE FEATURES

- For high pressure applications up to 900 bar
- No pressure difference required
- High life time
- Simple compact valve design
- High-quality materials
- Reliable and sturdy sealing elements

FUNCTION

NC – non energized closed

NO – non-energized open

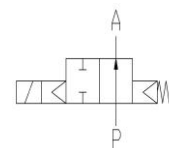
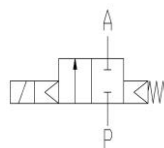

CONNECTION DIAGRAM

For AC/DC coils

For DC coils
w/ integr. rectifier

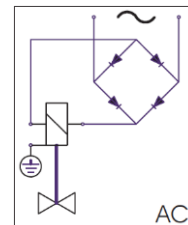
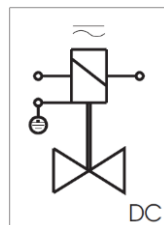

CERTIFICATES



TECHNICAL FEATURES

[With solenoid system .032 // .012 // .148]

Seat Ø mm	Kv-value m³/h	Standard type	max. pressure for coils		
			.032-S	.012-S	.148-S (ATEX)
0,5	0,014	.554E/0615/	0-300	-	0-250
0,7	0,020	.554G/0615/	0-210	0-500	0-170
0,8	0,025	.554H/0615/	0-170	0-250	0-170
1,0	0,032	.5540/0615/	-	0-200	-

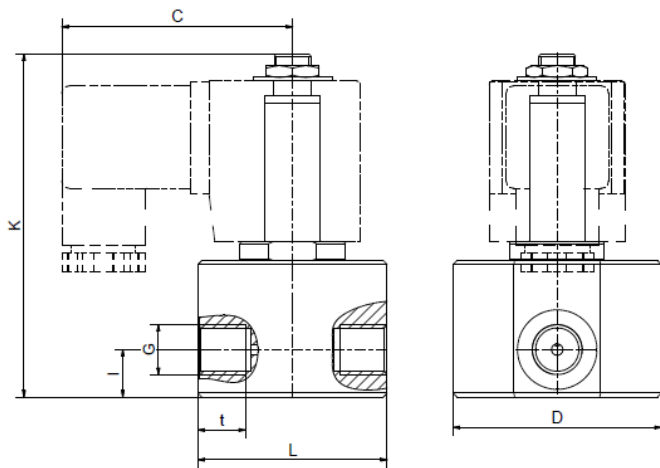

Coil	.032-S	.012-S / .148-S *
G	1/4	1/4
C	59	61
D	55	55
K	90,5	90,5
I	12,5	12,5
L	50	50
t	12,5	12,5
kg	0,9	0,9

*Differing dimension "C" for ATEX coils

[With solenoid system .802 // .808]

Seat Ø mm	Kv-value m³/h	Standard type	max. pressure for coils	
			.802	.808 (ATEX)
mm	m³/h		NC	NC
0,5	0,014	.554E/0815/	0-900	0-900
0,7	0,020	.554G/0815/	0-600	0-500
0,8	0,025	.554H/0815/	0-450	0-350

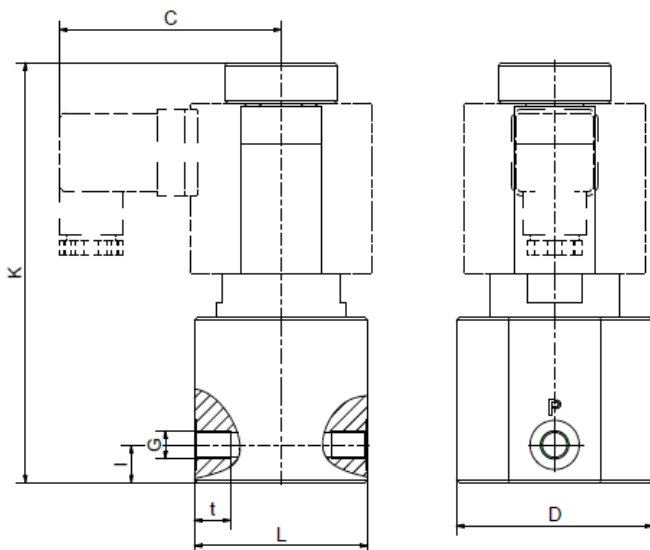

Coil	.802 / .808 *
G	1/4
C	70
D	68
K	122
I	12,5
L	60
t	12,5
kg	1,9

*Differing dimension "C" for ATEX coils

TECHNICAL FEATURES

[With solenoid system .702 // .692-NO // .802 // .322 // .242]

Brass			max. pressure for coils													
Seat Ø mm	Kv- value m³/h	Standard type	.702/.692		.802		.808		.322		.328		.242		.248	
			NC	NO	NC	NO	NC	NO	NC	NO	NC	NO	NC	NO	NC	NO
1,0	0,034	.5540/1004/	-	-	200	100	200	100	200	200	-	-	-	-	-	-
1,5	0,06	.5541/1004/	100	80	140	80	140	80	200	180	120	80	-	-	-	-
2,0	0,13	.5542/1004/	80	40	100	50	100	50	180	160	90	70	200	200	200	200
2,5	0,16	.5543/1004/	50	28	50	40	50	40	110	110	60	60	200	180	200	100
3,0	0,25	.5544/1004/	35	20	40	25	40	25	80	80	40	40	150	120	110	70
4,0	0,50	.5545/1004/	16	12	25	15	25	15	40	35	25	25	100	60	80	60
5,0	0,55	.5546/1004/	12	6	16	9	16	9	28	20	12	12	60	40	40	30
6,0	0,60	.5547/1004/	10	4	12	6	10	6	20	14	10	10	45	30	25	20

Stainless steel			max. pressure for coils													
Seat Ø mm	Kv- value m³/h	Standard type	.702/.692		.802		.808		.322		.328		.242		.248	
			NC	NO	NC	NO	NC	NO	NC	NO	NC	NO	NC	NO	NC	NO
1,0	0,034	.5540/06../	-	-	350	100	200	100	350	350	300	200	450	400	450	350
1,5	0,06	.5541/06../	100	80	140	80	140	80	330	180	120	80	410	300	320	250
2,0	0,13	.5542/06../	80	40	100	50	100	50	180	160	90	70	300	200	200	200
2,5	0,16	.5543/0604/	50	28	50	40	50	40	110	110	60	60	200	180	200	100
3,0	0,25	.5544/0604/	35	20	40	25	40	25	80	80	40	40	150	120	110	70
4,0	0,50	.5545/0604/	16	12	25	15	25	15	40	35	25	25	100	60	80	60
5,0	0,55	.5546/0604/	12	6	16	9	16	9	28	20	12	12	60	40	40	30
6,0	0,60	.5547/0604/	10	4	12	6	10	6	20	14	10	10	45	30	25	20

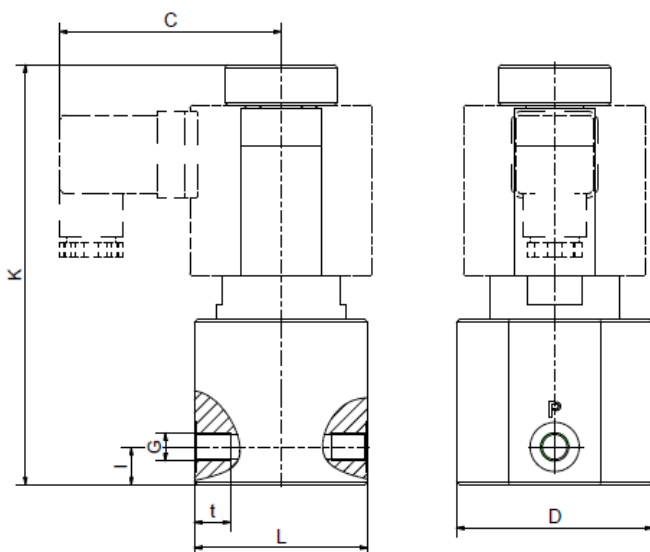

Coil	.702/.692	.802/.808	.322/.328	.242/.248
G	1/4	1/4	1/4	1/4
C	67	70	77	92,5
D	68	68	68	68
K	109	113	145	166
I	12,5	12,5	13	13
L	60	60	60	60
t	12,5	12,5	12,5	12,5
kg	1,9	2,0	3,0	4,4

*Differing dimension "C" for ATEX coils

INFORMATION

- It is imperative to observe the installation and safety instructions in our operating and service manuals.
- Required ordering information: valve type, function NC/NO, pressure range, connection, nominal width, medium, flow rate, medium and ambient temperatures, connection voltage.
- **For information on the heating and performance of solenoid coils, refer to the corresponding "Coils" data sheet.**
- **Detailed production-specific drawings and other technical information will be made available when an order is placed.**

PLEASE NOTE

Each individual application decides which valve type is required, the main factor being the resistance of the materials to the operating medium. The correct selection of materials requires knowledge of the concentration, temperature and degree of contamination of the medium. Other criteria include the operating pressure and max. volumetric flow, since, in addition to high temperatures, high pressures and high flow rates must also be taken into account when selecting the materials.

All materials used for our valves, be it housing, seals or magnets, will be carefully selected in view of the different application areas. Any information given is non-binding and serves for orientation only. No claims under warranty can be derived therefrom.

ORDERING CODE

Type	Connection		Body	Sealing		Coil		Option
. 55	4 0	/	0 8	1 5	/	. 8 0	2	- X X

3 .	G 1/8
4 .	G 1/4
5 .	G 3/8
6 .	G 1/2
. E	0,5 mm
. G	0,7 mm
. H	0,8 mm
. 0	1,0 mm
. 1	1,5 mm
. 2	2,0 mm
. 3	2,5 mm
. 4	3,0 mm
. 5	4,0 mm
. 6	5,0 mm

06	St.steel 1.4301
08	St.steel 1.4571
10	Brass
13	St.steel 1.4404 *

04	PTFE
15	PEEK *
19	XHPU

03	11 W	2	Standard IP65
01	18 W	8	2014/34/EU (ATEX)
70	25 W		
69	25 W		
80	24 W		
32	30 W		
24	46 W		

NO	normally open
1W	Hydrogen

* always in conjunction with option 1W and pressure > 100 b ar for hydrogen applications.

