



2/2-way solenoid valve

NC - Valve normally closed (as standard)

NO - Valve normally open (as option)

Direct operated valve.

No differential pressure is necessary for operation. When energized, the valve seat is opened directly.

In standard (NC) the valve closes with spring power.

■ Solenoid valve for gaseous and liquid media

TECHNICAL SPECIFICATIONS

Type of control	Direct operated valve, no pressure difference required
Design	Piston design
Connection	Sleeve connection G1/8 - G1/2 DIN ISO 228/1 (BSP) <small>Further connections like NPT on request</small>
Installation	Actuator upright or lateral
Pressure	0 - 90 bar (see table on page 2)
Medium	Clean, neutral gaseous and liquid media
Max. viscosity	22 mm ² /s
Temperature range	Medium: -10 °C / +80 °C Environment: -10 °C / +50 °C <small>Taking into account other influencing parameters</small>
Body material	Brass 2.0401, 2.0402 Stainless steel 1.4301, 1.4571
Metallic inner parts	Brass and st. steel
Sealing	FKM, EPDM, PTFE
Supply voltage	AC~ 24V, 110V, 230V DC= 12V, 24V <small>Other supply voltages on request</small>
Voltage tolerance	-10% / +10%
Power consumption	.182 = 6,8 Watt .178 = 5,2 Watt ⚠ .032 = 11 Watt .148 = 10 Watt ⚠ .012 = 18,5 Watt
Protection class	IP65 according to DIN 60529
Duty factor	100% ED-VDE 0580
Connection type	Device plug DIN 43650
Ex-proof	acc. to 2014/34/EU (ATEX)
Option	



Filter 100 µm, Stainless steel 1.4301
Integrated in option GI
Can be retrofitted as article
B0021.000096

VALVE FEATURES

- Works without pressure difference
- Long service life
- Simple, compact valve design
- Reliable, resilient sealing elements
- Long-term availability of spare parts sets
- Option GI: with integrated filter element (can also be retrofitted)

FUNCTION

NC – non energized closed

NO – non-energized open

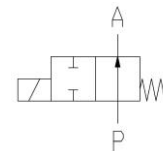
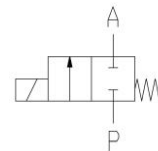

CONNECTION DIAGRAM

For AC/DC coils

For DC coils

w/ integr. rectifier

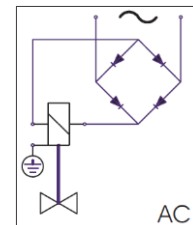
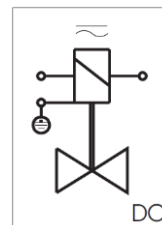

CERTIFICATES



TECHNICAL FEATURES

Seat Ø mm	Kv-value m³/h	Standard type	max. pressure for coils NC			ATEX NC	
			.182	.032	.012	.178	.148
1,0	0,06	.5240/..02/	0-50	0-90	0-90	0-20	0-90
1,5	0,09	.5241/..02/	0-30	0-85	0-90	0-16	0-90
2,0	0,13	.5242/..02/	0-15	0-40	0-90	0-10	0-55
2,5	0,16	.5243/..02/	0-8	0-22	0-45	0-6	0-28
3,0	0,20	.5244/..02/	-	0-15	0-30	-	0-20
4,0	0,35	.5245/..02/	-	0-8	0-16	-	0-10
5,0	0,50	.5246/..02/	-	0-5	0-10	-	0-6
6,0	0,75	.5247/..02/	-	0-4	0-8	-	0-5

Seat Ø mm	Kv-value m³/h	Standard type	max. pressure for coils NO		ATEX NO
			.032	.012	.148
1,0	0,06	.5240/..02/....-NO	0-25	0-90	0-40
1,5	0,09	.5241/..02/....-NO	0-12	0-40	0-20
2,0	0,13	.5242/..02/....-NO	0-12	0-22	0-12
2,5	0,16	.5243/..02/....-NO	0-9	0-14	0-5
3,0	0,20	.5244/..02/....-NO	0-7	0-10	0-2,5
4,0	0,35	.5245/..02/....-NO	-	0-5	0-2

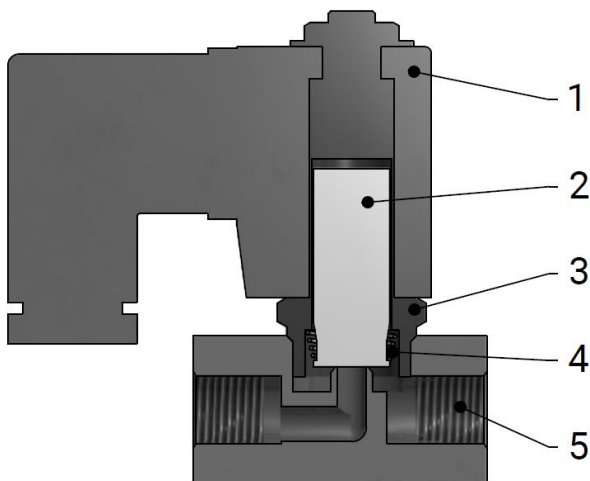

Description	
1	Solenoid coil
2	Plunger
3	Tube
4	Spring
5	Valve body



DIMENSIONS

Type .5230-35 / .5240-45 / Forged brass

Type .5230-37 / .5240-47 / Stainless steel

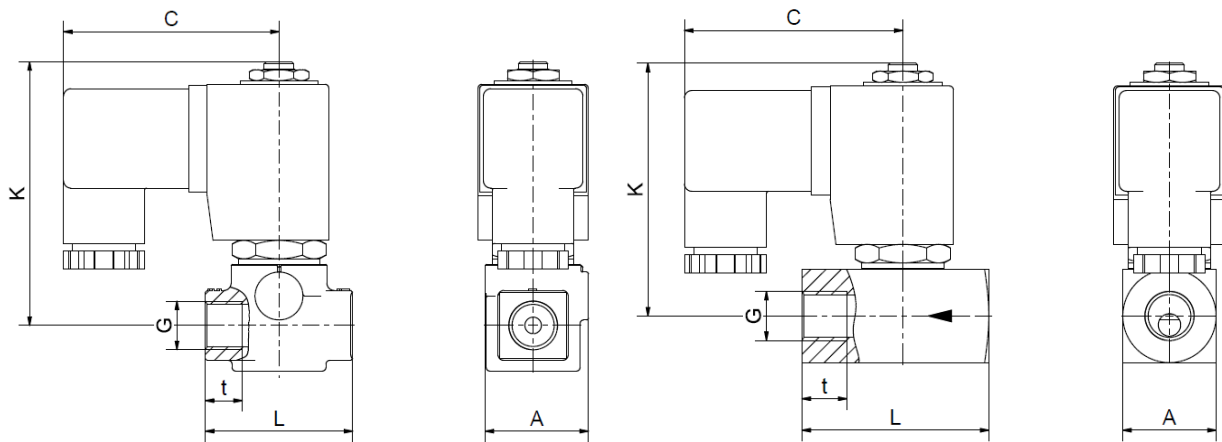

Coil	.182 / .178*		.032		.012 / .148*		
Type	.5230-33/	.5230-35/		.5236-37	.5230-35/		.5236-37
		Brass	Stainless steel		Brass	Stainless steel	
G	1/8	1/8	1/8	1/8	1/8	1/8	1/8
A	15	28	25	25	28	25	25
C	55	59	59	59	61	61	61
K	44	72	68	68	72	68	68
L	32	40	40	40	40	40	40
t	15	10	7	7	10	7	7
kg	0,2	0,4	0,45	0,5	0,4	0,45	0,6

*Differing dimension "C" for ATEX coils

Coil	.182 / .178*		.032		.012 / .148*		
Type	.5240-43/	.5240-45/		.5246-37	.5240-45/		.5246-47
		Brass	Stainless steel		Brass	Stainless steel	
G	1/4	1/4	1/4	1/4	1/4	1/4	1/4
A	20	28	25	25	28	25	25
C	55	59	59	59	61	61	61
K	47	72	68	68	72	68	68
L	40	40	50	50	40	50	50
t	9	10	12	12	10	12	12
kg	0,25	0,4	0,5	0,55	0,5	0,6	0,65

*Differing dimension "C" for ATEX coils



DIMENSIONS

Type .5250-57 / .5260-67

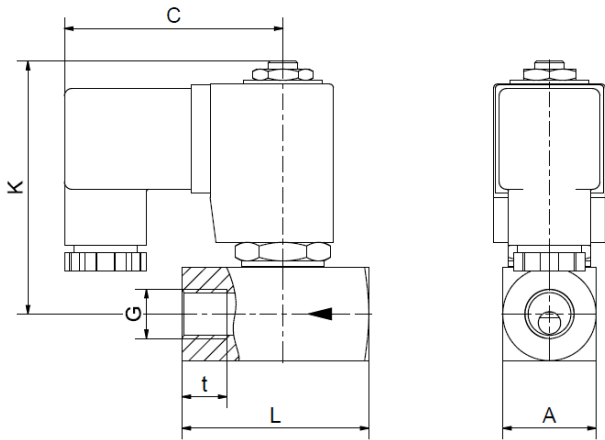

Coil	.182 / .178*	.032	.012 / .148*	.182 / .178*	.032	.012 / .148*
Type	.5250-53	.5250-57	.5250-57	.5260-63/	.5260-67	.5260-67
G	3/8	3/8	3/8	1/2	1/2	1/2
A	25	25	25	30	30	30
C	55	59	61	55	59	61
K	49	68	68	52	71	71
L	50	50	50	60	60	60
t	12	12	12	14	14	14
kg	0,35	0,45	0,55	0,35	0,6	0,7

*Differing dimension "C" for ATEX coils



INFORMATION

- It is imperative to observe the installation and safety instructions in our operating and service manuals.
- Required ordering information: valve type, function NC/NO, pressure range, connection, nominal width, medium, flow rate, medium and ambient temperatures, connection voltage.
- **For information on the heating and performance of solenoid coils, refer to the corresponding "Coils" data sheet.**
- **Detailed production-specific drawings and other technical information will be made available when an order is placed.**

PLEASE NOTE

Each individual application decides which valve type is required, the main factor being the resistance of the materials to the operating medium. The correct selection of materials requires knowledge of the concentration, temperature and degree of contamination of the medium. Other criteria include the operating pressure and max. volumetric flow, since, in addition to high temperatures, high pressures and high flow rates must also be taken into account when selecting the materials.

All materials used for our valves, be it housing, seals or magnets, will be carefully selected in view of the different application areas. Any information given is non-binding and serves for orientation only. No claims under warranty can be derived therefrom.

ORDERING CODE

Type	Connection		Body	Sealing		Coil			Option	
. 52	4 1	/	1 0	0 2	/	.	1 8	2	-	X X

3 .	G 1/8
4 .	G 1/4
5 .	G 3/8
6 .	G 1/2
. 0	1.0 mm
. 1	1.5 mm
. 2	2.0 mm
. 3	2.5 mm
. 4	3.0 mm
. 5	4.0 mm
. 6	5.0 mm
. 7	6.0 mm

06	St.steel 1.4301
08	St.steel 1.4571
10	Brass 2.0402
02	FKM
04	PTFE
06	EPDM

18	10,5 VA / 6,8 W	2	Standard IP65
03	15 VA / 11 W	8	2014/34/EU (ATEX)
01	24 VA / 18,5 W		
17	5,3 VA / 5,2 W		
14	8,5 VA / 10 W		

NO	normally open
O	Oxygen
OF	cleaned
HA	manual override
GI	filter element