



2/2-way solenoid valve
NC - Valve normally closed (as standard)
NO - Valve normally open (as option)

Force-pilot operated diaphragm valve
No differential pressure is necessary for operation.
In standard (NC) the valve closes with spring power.

■ **Solenoid valve for gaseous and liquid media**

TECHNICAL SPECIFICATIONS

Type of control	Force-pilot operated, no pressure difference necessary
Design	Seat valve with diaphragm seal
Connection	Sleeve connection G 1/4 - G 2 DIN ISO 228/1 (BSP) <small>Further connections like NPT on request</small>
Installation	Actuator upright
Pressure	0 - 16 bar (see table on page 2) <small>At a pressure < 0.3 bar, the internal tightness decreases.</small>
Medium	Clean, neutral gaseous and liquid media
Max. viscosity	22 mm ² /s
Temperature range	Medium: -10 °C / +80 °C Environment: -10 °C / +50 °C <small>Taking into account other influencing parameters</small>
Body material	Brass 2.0402 Stainless steel 1.4581
Metallic inner parts	Brass and st. steel
Sealing	NBR, FKM, EPDM
Supply voltage	AC~ 24V, 110V, 230V DC= 12V, 24V <small>Other supply voltages on request</small>
Voltage tolerance	-10% / +10%
Power consumption	.032 = 11 Watt .148 = 10 Watt ⚠ .012 = 18 Watt .702 = 25 Watt .692 = 25 Watt .802 = 24 Watt .808 = 24 Watt ⚠ .322 = 30 Watt .328 = 24 Watt ⚠ .242 = 46 Watt .248 = 30 Watt ⚠ .272 = 100 Watt .278 = 47 Watt ⚠
Protection class	IP65 according to DIN 60529
Duty factor	100% ED-VDE 0580
Connection type	Device plug DIN 43650, terminal box
Ex-proof	acc. to 2014/34/EU (ATEX)

VALVE FEATURES

- No pressure difference required
- High life time
- Simple compact valve design
- Reliable and sturdy sealing elements
- Long-term availability of spare parts

FUNCTION

NC – non energized closed

NO – non-energized open

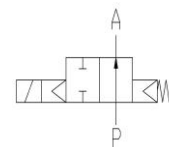
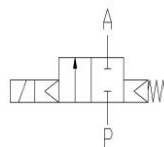

CONNECTION DIAGRAM

For AC/DC coils

For DC coils
w/ integr. rectifier

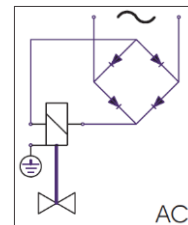
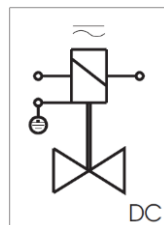

CERTIFICATES



TECHNICAL FEATURES

G	Seat Ø mm	Kv-value m³/h	Standard type	max. pressure for coils					
				.032	.012	.702 .802	.322	.242	.272
1/4	13,5	1,8	.4321/..01/	0-10	0-16	0-16	-	-	-
3/8	13,5	3,6	.4322/..01/	0-10	0-16	0-16	-	-	-
1/2	13,5	3,9	.4323/..01/	0-10	0-16	0-16	-	-	-
3/4	27,5	10,8	.4324/..01/	0-6	0-12	0-16	-	-	-
1	27,5	13,0	.4325/..01/	0-6	0-12	0-16	-	-	-
1 1/4	40	22,0	.4326/..01/	-	-	-	0-10	0-16	0-16
1 1/2	40	25,0	.4327/..01/	-	-	-	0-10	0-16	0-16
2	50	30,0	.4328/..01/	-	-	-	0-6	0-16	0-16

The Kv values in the table apply to the larger drive

G	Seat Ø mm	Kv-value m³/h	Standard type	max. pressure for coils ATEX				
				.148	.808	.328	.248	.278
1/4	13,5	1,8	.4321/..01/	0-10	0-16	-	-	-
3/8	13,5	3,6	.4322/..01/	0-10	0-16	-	-	-
1/2	13,5	3,9	.4323/..01/	0-10	0-16	-	-	-
3/4	27,5	10,8	.4324/..01/	0-5	0-16	-	-	-
1	27,5	13,0	.4325/..01/	0-5	0-16	-	-	-
1 1/4	40	22,0	.4326/..01/	-	-	0-3	0-10	0-16
1 1/2	40	25,0	.4327/..01/	-	-	0-3	0-10	0-16
2	50	30,0	.4328/..01/	-	-	0-3	0-6	0-16

The Kv values in the table apply to the larger drive

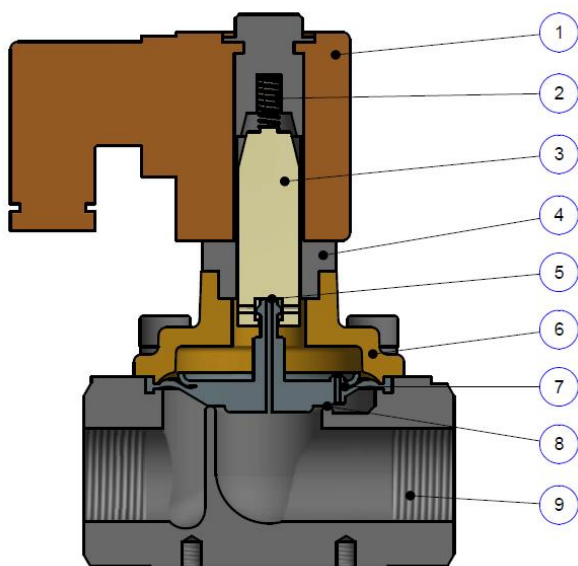

Description	
1	Solenoid coil
2	Spring
3	Plunger
4	Tube
5	Pilot seat
6	Bonnet
7	Diaphragm
8	Valve seat
9	Valve body

DIMENSIONS

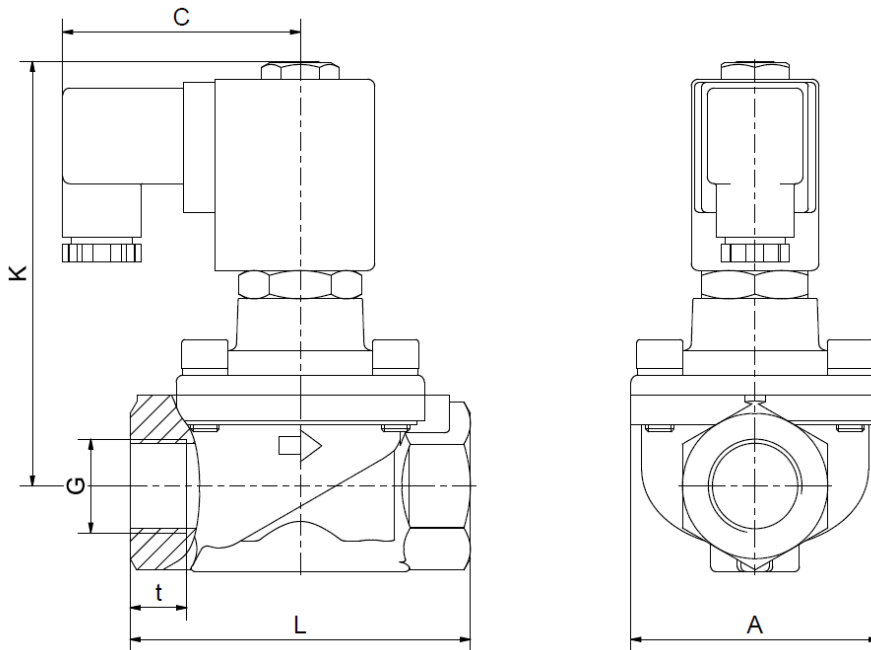

Coil	.032 / .012 / .148		.702 (.692) **		.802 / .808 (.802-NO / .808-NO)	
Type	4321-23	4324-25	4321-23	4324-25	4321-23	4324-25
G	1/4 - 1/2	3/4 - 1	1/4 - 1/2	3/4 - 1	1/4 - 1/2	3/4 - 1
A	48	70	48	70	48	70
C	61	61	67	67	67	67
K	86	96	103 (144)	120 (156)	107 (144)	124 (161)
L	67	96	67	96	67	96
t	12	16	12	16	12	16
kg	0,85	1,5	1,1	1,8	1,1	1,7

*Differing dimension "C" for ATEX coils

** Magnetic system .702 (.692) no longer available from 2025.

Values in brackets refer to the NO version

Coil	.322 / .328			.242 / .248			.272 / .278		
Type	4326	4327	4328	4326	4327	4328	4326	4327	4328
G	1 1/4	1 1/2	2	1 1/4	1 1/2	2	1 1/4	1 1/2	2
A	96	96	112	96	96	112	96	96	112
C	77	77	77	93	93	93	107	107	107
K	173	173	179	196	196	205	243	243	251
L	140	140	168	140	140	168	140	140	168
t	22	22	25	22	22	25	22	22	25
kg	4,8	4,5	5,8	6,2	5,9	7,2	10,2	9,9	11,3

*Differing dimension "C" for ATEX coils



INFORMATION

- It is imperative to observe the installation and safety instructions in our operating and service manuals.
- Required ordering information: valve type, function NC/NO, pressure range, connection, nominal width, medium, flow rate, medium and ambient temperatures, connection voltage.
- **For information on the heating and performance of solenoid coils, refer to the corresponding "Coils" data sheet.**
- **Detailed production-specific drawings and other technical information will be made available when an order is placed.**

PLEASE NOTE

Each individual application decides which valve type is required, the main factor being the resistance of the materials to the operating medium. The correct selection of materials requires knowledge of the concentration, temperature and degree of contamination of the medium. Other criteria include the operating pressure and max. volumetric flow, since, in addition to high temperatures, high pressures and high flow rates must also be taken into account when selecting the materials.

All materials used for our valves, be it housing, seals or magnets, will be carefully selected in view of the different application areas. Any information given is non-binding and serves for orientation only. No claims under warranty can be derived therefrom.

ORDERING CODE

Type	Connection		Body	Sealing		Coil		Option
. 43	2 3	/	1 0	0 1	/	. 0 1	2	- X X

21	G 1/4
22	G 3/8
23	G 1/2
24	G 3/4
25	G 1
26	G 5/4
27	G 6/4
28	G 2
28	G 2

08	St.steel 1.4581
10	Brass 2.0402
01	NBR
02	FKM
06	EPDM

03	15 VA / 11 W
01	24 VA / 18,5 W
14	8,5 VA / 10 W
70	25 W
69	25 W
80	24 W
32	30 W
24	46 W
27	100 W

2	Standard IP65
8	2014/34/EU (ATEX)
NO	normally open
HA	manual override
EA	limit switch
OF	cleaned