



2/2-way solenoid valve

NC - Valve normally closed (as standard)

NO - Valve normally open (as option)

Force-pilot operated piston valve

No differential pressure is necessary for operation.

In standard (NC) the valve closes with spring power.

■ Valve for extended temperature range

TECHNICAL SPECIFICATIONS

Type of control	Force-pilot operated, no pressure difference necessary
Design	Piston design
Connection	Flanges DN15 - DN50 EN 1092-1 Form B1/B2
Installation	Actuator upright
Pressure	0 - 40 bar (see table on page 2)
Medium	Clean, neutral gaseous and liquid media
Max. viscosity	22 mm ² /s
Temperature range	Medium: -60°C / +80°C Environment: -55°C / +50°C Taking into account other influencing parameters ATEX: -55°C / +40°C, +60°C (depending on ATEX coil)
Body material	Stainless steel 1.4581
Metallic inner parts	Stainless steel
Sealing	PTFE
Supply voltage	AC~ 24V, 110V, 230V DC= 12V, 24V Other supply voltages on request
Voltage tolerance	-10% / +10%
Power consumption	S802 = 18 Watt .808 = 24 Watt ☹ S322 = 21 Watt .328 = 24 Watt ☹ S242 = 26 Watt .248 = 30 Watt ☹ S272 = 60 Watt .278 = 30 Watt ☹ S352 = 80 Watt .358 = 75 Watt ☹
Protection class	IP65 according to DIN 60529
Duty factor	100% ED-VDE 0580
Connection type	terminal box
Ex-proof	acc. to 2014/34/EU (ATEX)

VALVE FEATURES

- For cold media to -60 °C
- No pressure difference is required
- High life time
- High-quality materials
- Reliable and sturdy sealing elements

FUNCTION

NC – non energized closed

NO – non-energized open

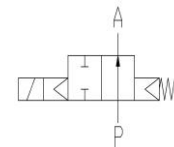
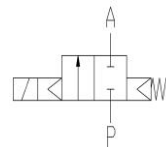

CONNECTION DIAGRAM

For AC/DC coils

For DC coils
w/ integr. rectifier

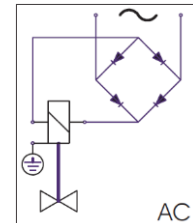
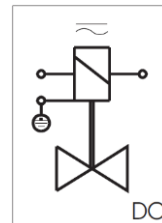

CERTIFICATES



TECHNICAL FEATURES

DN	Seat Ø mm	Kv-value m³/h	Standard type	max. pressure for coils				
				S802	S322*	S242	S272	S352
15	15	5,0	K3701/0804/	0-40	0-40	-	-	-
20	20	11,0	K3702/0804/	0-16	0-40	0-40	-	-
25	25	13,0	K3703/0804/	0-16	0-40	0-40	-	-
32	32	28,0	K3704/0804/	-	0-25	0-40	0-40	-
40	40	30,0	K3705/0804/	-	0-25	0-40	0-40	-
50	50	46,0	K3706/0804/	-	0-6	0-16	0-40	0-40

The flow rate mentioned in the table applies to the strongest coil.

* Pressure ranges may be reduced when using options such as manual override or limit switches.

DN	Seat Ø mm	Kv-value m³/h	Standard type	max. pressure for coils ATEX				
				.808	.328*	.248	.278	.358
15	15	5,0	K3701/0804/	0-30	0-40	-	-	-
20	20	11,0	K3702/0804/	0-12	0-25	0-40	-	-
25	25	13,0	K3703/0804/	0-12	0-25	0-40	-	-
32	32	28,0	K3704/0804/	-	0-16	0-25	0-40	-
40	40	30,0	K3705/0804/	-	0-16	0-25	0-40	-
50	50	46,0	K3706/0804/	-	0-2	0-10	0-16	0-40

The flow rate mentioned in the table applies to the strongest coil.

* Pressure ranges may be reduced when using options such as manual override or limit switches.

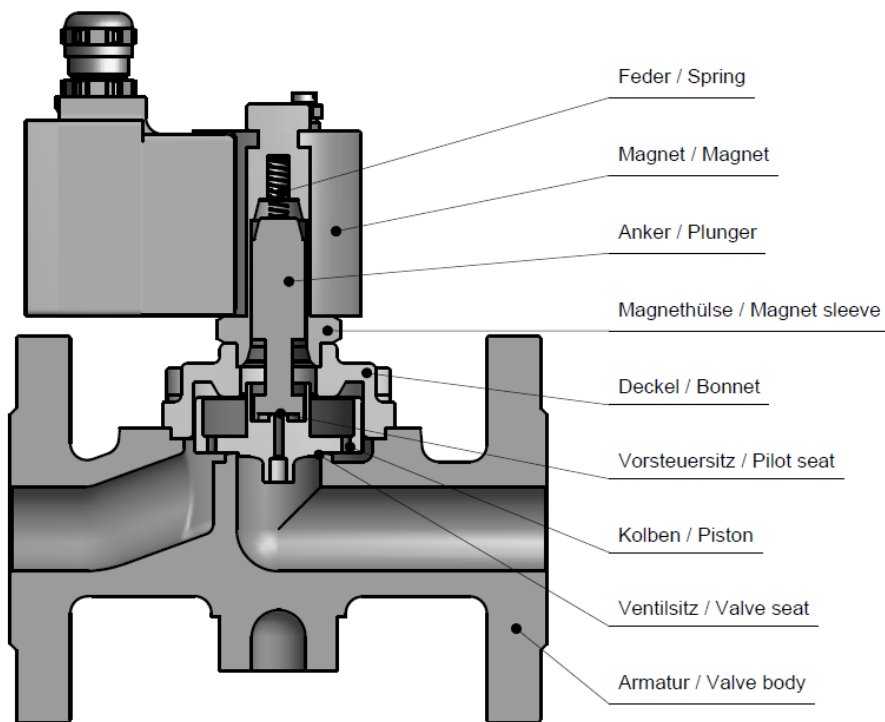

DIMENSIONS

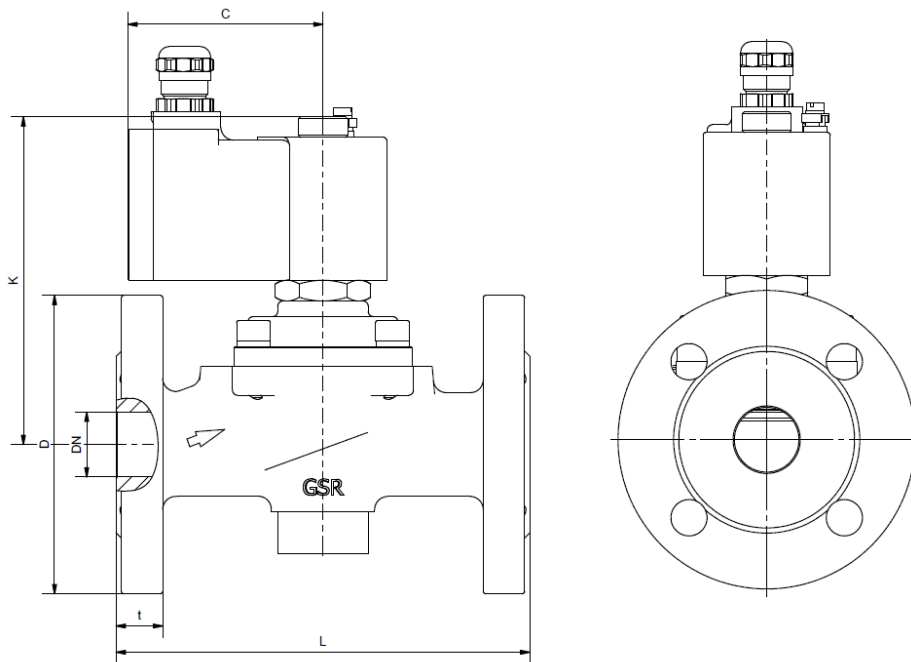

Coil	S802 / .808			S322 / .328					
	K3701	K3702	K3703	K3701	K3702	K3703	K3704	K3705	K3706
Type	K3701	K3702	K3703	K3701	K3702	K3703	K3704	K3705	K3706
DN	15	20	25	15	20	25	32	40	50
C	75	75	75	77	77	77	77	77	77
D	95	105	115	95	105	115	140	150	165
K	104	122	122	148	138	131	148	148	168
L	130	150	160	130	150	160	180	200	230
t	16	18	18	16	18	18	18	18	20
kg	2,9	4,4	4,4	3,6	4,8	5,3	7,9	8,4	11,0

Coil	S242 / .248					S272 / .278			S352 / .358
	K3702	K3703	K3704	K3705	K3706	K3704	K3705	K3706	K3706
Type	K3702	K3703	K3704	K3705	K3706	K3704	K3705	K3706	K3706
DN	20	25	32	40	50	32	40	50	50
C	93	93	93	93	93	106	106	106	126
D	105	115	140	150	165	140	150	165	165
K	194	178	188	188	186	218	230	240	319
L	150	160	180	200	230	180	200	230	230
t	16	18	18	18	20	18	18	20	20
kg	7,0	7,2	9,8	10,2	12,9	13,4	14,3	16,9	29,0



INFORMATION

- It is imperative to observe the installation and safety instructions in our operating and service manuals.
- Required ordering information: valve type, function NC/NO, pressure range, connection, nominal width, medium, flow rate, medium and ambient temperatures, connection voltage.
- **For information on the heating and performance of solenoid coils, refer to the corresponding "Coils" data sheet.**
- **Detailed production-specific drawings and other technical information will be made available when an order is placed.**

PLEASE NOTE

Each individual application decides which valve type is required, the main factor being the resistance of the materials to the operating medium. The correct selection of materials requires knowledge of the concentration, temperature and degree of contamination of the medium. Other criteria include the operating pressure and max. volumetric flow, since, in addition to high temperatures, high pressures and high flow rates must also be taken into account when selecting the materials.

All materials used for our valves, be it housing, seals or magnets, will be carefully selected in view of the different application areas. Any information given is non-binding and serves for orientation only. No claims under warranty can be derived therefrom.

ORDERING CODE

Type	Connection	Body	Sealing	Coil	Option
K 37	0 1	0 8	0 4	S 8 0	2 - X X

01	DN15
02	DN20
03	DN25
04	DN32
05	DN40
06	DN50

08	St.steel 1.4581
04	PTFE

80	18 W
32	21 W
24	26 W
27	60 W
35	80 W

2	Standard IP65
8	2014/34/EU (ATEX)

NO	normally open
AX	ANSI Flanges