



2/2-way solenoid valve
 NC - Valve normally closed (as standard)
 NO - Valve normally open (as option)

Force-pilot operated piston valve
 No differential pressure is necessary for operation.
 In standard (NC) the valve closes with spring power.

■ Solenoid valve for extended temperature range

TECHNICAL SPECIFICATIONS

Type of control	Force-pilot operated, no pressure difference necessary
Design	Piston design
Connection	Sleeve connection G1/4 - G2 DIN ISO 228/1 (BSP) <small>Further connections like NPT on request</small>
Installation	Actuator upright
Pressure	0 - 40 bar (see table on page 2)
Medium	Clean, neutral gaseous and liquid media
max. viscosity	22 mm ² /s
Temperature range	Medium: -60 °C / +80 °C Environment: -55 °C / +50 °C <small>Taking into account other influencing parameters</small>
Body material	Brass 2.0402 St. steel 1.4581
Metallic inner parts	Brass and st. steel
Sealing	PTFE
Supply voltage	AC~ 24V, 110V, 230V DC= 12V, 24V <small>Other supply voltages on request</small>
Voltage tolerance	-10% / +10%
Power consumption	S802 = 24 Watt .808 = 24 Watt ⚠ S322 = 30 Watt .328 = 24 Watt ⚠ .242 = 46 Watt .248 = 30 Watt ⚠ .272 = 100 Watt .278 = 47 Watt ⚠
Protection class	IP65 according to DIN 60529
Duty factor	100% ED-VDE 0580
Connection type	terminal box
Ex-proof	acc. to 2014/34/EU (ATEX)

VALVE FEATURES

- For cold media to -60 °C
- No pressure difference is required
- High life time
- High-quality materials
- Reliable and sturdy sealing elements

FUNCTION

NC – non energized closed

NO – non-energized open

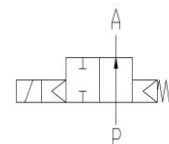
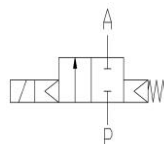

CONNECTION DIAGRAM

For AC/DC coils

For DC coils
 w/ integr. rectifier

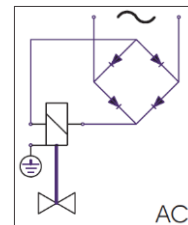
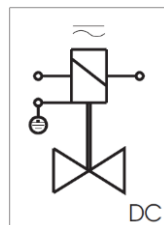

CERTIFICATES



TECHNICAL FEATURES

G	Seat Ø mm	Kv-value m³/h	Standard type	max. pressure for coils							
				S802		S322*		.242		.272	
				NC	NO	NC	NO	NC	NO	NC	NO
1/4	13,5	1,8	.3521/..04/	0-40	0-30	0-40	0-40	-	-	-	-
3/8	13,5	4,0	.3522/..04/	0-40	0-30	0-40	0-40	-	-	-	-
1/2	13,5	4,5	.3523/..04/	0-40	0-30	0-40	0-40	-	-	-	-
3/4	27,5	11,5	.3524/..04/	0-16	0-12	0-40	0-25	0-40	0-40	-	-
1	27,5	13,0	.3525/..04/	0-16	0-12	0-40	0-25	0-40	0-40	-	-
1 1/4	40	29,0	.3526/..04/	-	-	0-25	0-16	0-40	0-40	0-40	0-40
1 1/2	40	33,0	.3527/..04/	-	-	0-25	0-10	0-40	0-40	0-40	0-40
2	50	49,0	.3528/..04/	-	-	0-6	-	0-16	0-16	0-40	0-40

The flow rate mentioned in the table applies to the strongest coil.

* Pressure ranges may be reduced when using options such as manual override or limit switches.

G	Seat Ø mm	Kv-value m³/h	Standard type	max. pressure for coils ATEX 			
				.808	.328*	.248	.278
1/4	13,5	1,8	.3521/..04/	0-30	0-40	-	-
3/8	13,5	4,0	.3522/..04/	0-30	0-40	-	-
1/2	13,5	4,5	.3523/..04/	0-30	0-40	-	-
3/4	27,5	11,5	.3524/..04/	0-12	0-25	0-40	-
1	27,5	13,0	.3525/..04/	0-12	0-25	0-40	-
1 1/4	40	29,0	.3526/..04/	-	0-16	0-25	0-40
1 1/2	40	33,0	.3527/..04/	-	0-16	0-25	0-40
2	50	49,0	.3528/..04/	-	0-2	0-10	0-16

The flow rate mentioned in the table applies to the strongest coil.

* Pressure ranges may be reduced when using options such as manual override or limit switches.

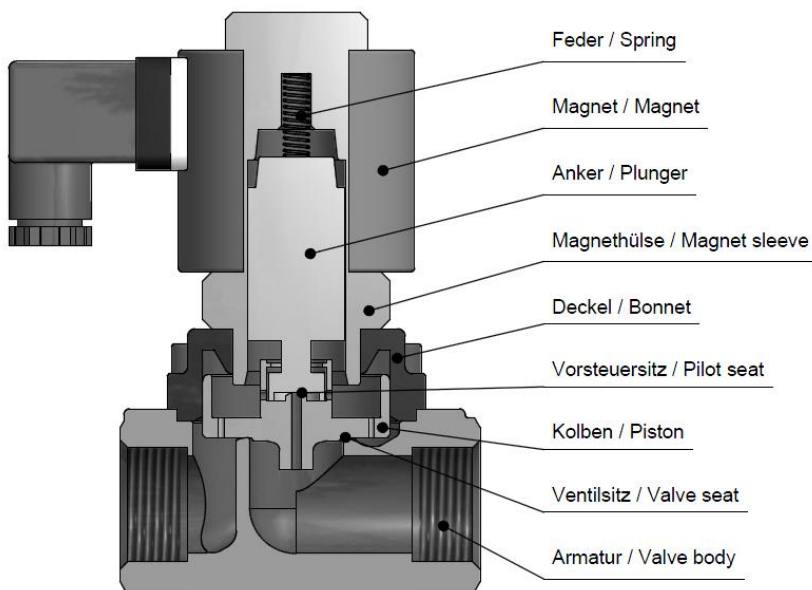

DIMENSIONS

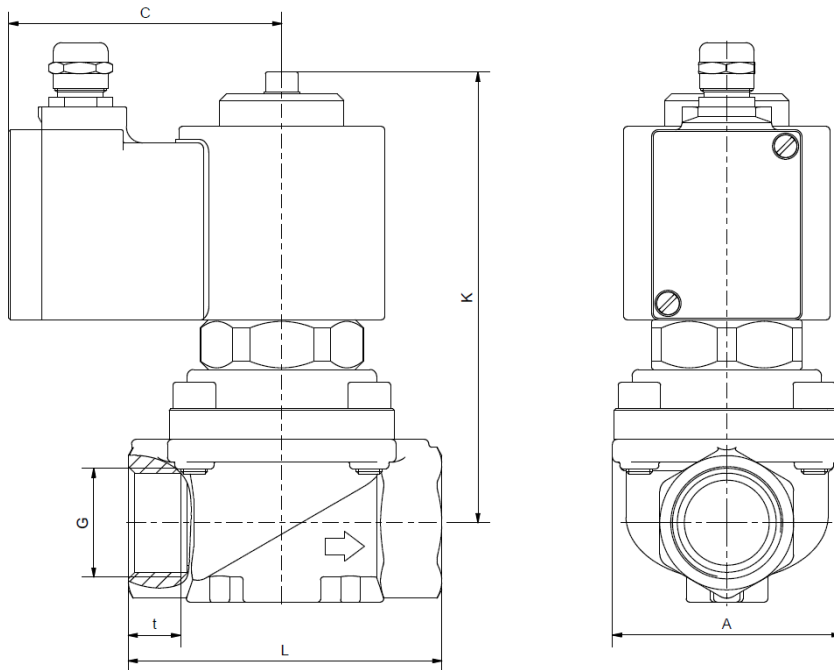

Coil	S802 / .808					S322 / .328				
Type	K3521	K3522	K3523	K3524	K3525	K3521	K3522	K3523	K3524	K3525
G	1/4	3/8	1/2	3/4	1	1/4	3/8	1/2	3/4	1
A	48	48	48	70	70	48	48	48	70	70
C	70	70	70	70	70	77	77	77	77	77
K	104	104	104	122	122	148	148	148	138	138
L	67	67	67	96	96	67	67	67	96	96
t	12	12	12	16	16	12	12	12	16	16
kg	1,5	1,5	1,4	2,3	2,2	2,4	2,3	2,3	3,1	3,0

Coil	S322/ .328		.242 / .248				.272 / .278			
Type	K3526	K3527	K3524	K3525	K3526	K3527	K3528	K3526	K3527	K3528
G	1 1/4	1 1/2	3/4	1	1 1/4	1 1/2	2	1 1/4	1 1/2	2
A	96	96	70	70	96	96	112	96	96	112
C	77	77	93	93	93	93	93	107	107	107
K	148	148	178	178	188	188	186	218	218	239
L	140	140	96	96	140	140	168	140	140	168
t	22	22	16	16	22	22	22	22	22	22
kg	4,8	4,7	4,7	4,6	6,5	6,3	7,6	10,1	10,0	11,5



INFORMATION

- It is imperative to observe the installation and safety instructions in our operating and service manuals.
- Required ordering information: valve type, function NC/NO, pressure range, connection, nominal width, medium, flow rate, medium and ambient temperatures, connection voltage.
- **For information on the heating and performance of solenoid coils, refer to the corresponding "Coils" data sheet.**
- **Detailed production-specific drawings and other technical information will be made available when an order is placed.**

PLEASE NOTE

Each individual application decides which valve type is required, the main factor being the resistance of the materials to the operating medium. The correct selection of materials requires knowledge of the concentration, temperature and degree of contamination of the medium. Other criteria include the operating pressure and max. volumetric flow, since, in addition to high temperatures, high pressures and high flow rates must also be taken into account when selecting the materials.

All materials used for our valves, be it housing, seals or magnets, will be carefully selected in view of the different application areas. Any information given is non-binding and serves for orientation only. No claims under warranty can be derived therefrom.

ORDERING CODE

Type	Connection	Body	Sealing	Coil	Option
K 3 5	2 3	1 0	0 4	S 8 0	2 - X X

21	G 1/4
22	G 3/8
23	G 1/2
24	G 3/4
25	G 1
26	G 5/4
27	G 6/4
28	G 2

08	St. steel 1.4581
10	Brass 2.0402
04	PTFE

80	24 W
32	30 W
24	46 W
27	100 W

2	Standard IP65
8	2014/34/EU (ATEX)

NO	normally open
HA	manual override
OF	cleaned