



- 2/2-way pressure controlled valve
- NC - Valve normally closed (as standard)
- NO - Valve normally open (as option)
- DW - Valve with double acting actuator (as option)

Direct pressure controlled valve.

The valve seat is opened against a spring force via the control medium.

- Valve for clean, gaseous and liquid media

TECHNICAL SPECIFICATIONS

Type of control	Direct pressure operated
Design	Seat valve with diaphragm seal
Connection	Flanges DN15 - DN50 EN 1092-1 Form B1/B2
Installation	Preferable with actuator upright
Pressure	0 - 10 bar (see table on page 2)
Medium	Clean, neutral gaseous and liquid media
Max. viscosity	50 mm ² /s
Temperature range	Medium: -10 °C / +80 °C Environment: -10 °C / +50 °C
Body material	Ductile cast EN-GJS-400-18-LT
Metallic inner parts	PFA coated
Sealing	2-piece PTFE diaphragm
Pilot pressure	6 bar
Pilot medium	Clean, neutral gaseous

Pilot valve

A7241/1002/...



3/2-way direct operated, NC
G1/4, Seat Ø mm 1,5mm, 0-8 bar
brass / st.steel / FKM

VALVE FEATURES

- No pressure difference required
- High life time
- High-quality materials
- Reliable and sturdy sealing elements
- Long-term availability of spare parts
- NO - non-pressurized open as option
- DW - double acting as option

FUNCTION

NC – non pressurized closed

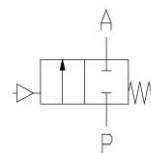

NO – non pressurized open

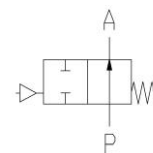

DW - double acting

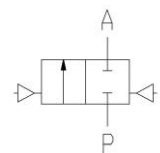

TECHNICAL FEATURES

			Pressure
DN	Kv-value m ³ /h	Standard type	bar
15	5,0	3/151-01-0304	0-10
20	9,0	3/151-02-0304	0-10
25	13,0	3/151-03-0304	0-10
32	23,0	3/151-04-0304	0-10
40	26,0	3/151-05-0304	0-10
50	50,0	3/151-06-0304	0-10

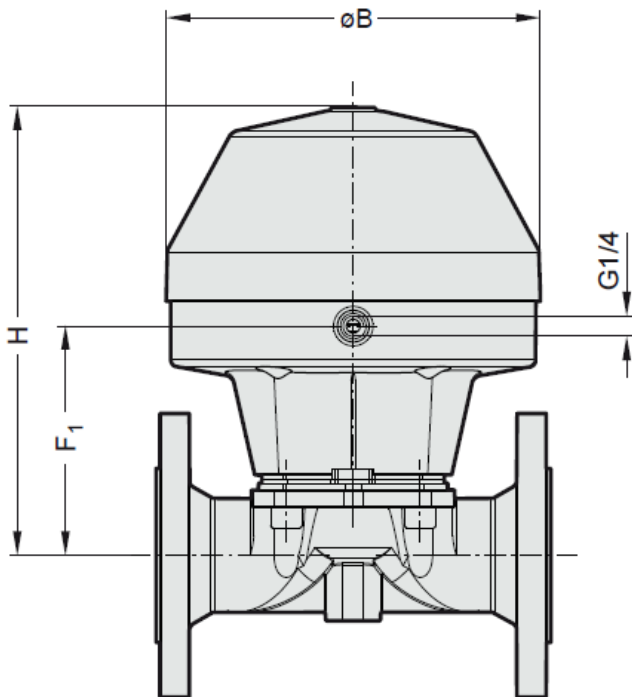

	3/151-01	3/151-02	3/151-03	3/151-04	3/151-05	3/151-06
Type	3/151-01	3/151-02	3/151-03	3/151-04	3/151-05	3/151-06
DN	15	20	25	32	40	50
B	130	130	130	161	161	218
F1	66	66	70	108	108	127
H	160	160	160	208	213	263
Inst. length	130	150	160	180	200	230
kg	3,6	4,4	4,9	9,0	9,0	15,0



INFORMATION

- It is imperative to observe the installation and safety instructions in our operating and service manuals.
- Required ordering information: valve type, function NC/NO, pressure range, connection, nominal width, medium, flow rate, medium and ambient temperatures, connection voltage.
- **For information on the heating and performance of solenoid coils, refer to the corresponding "Coils" data sheet.**
- **Detailed production-specific drawings and other technical information will be made available when an order is placed.**

PLEASE NOTE

Each individual application decides which valve type is required, the main factor being the resistance of the materials to the operating medium. The correct selection of materials requires knowledge of the concentration, temperature and degree of contamination of the medium. Other criteria include the operating pressure and max. volumetric flow, since, in addition to high temperatures, high pressures and high flow rates must also be taken into account when selecting the materials.

All materials used for our valves, be it housing, seals or magnets, will be carefully selected in view of the different application areas. Any information given is non-binding and serves for orientation only. No claims under warranty can be derived therefrom.

ORDERING CODE

Type		Connection		Body	Sealing
3 / 1 5 1	-	0 2	-	0 3	0 4
		01 DN15		03 EN-GJS-400-18-LT	
		02 DN20			
		03 DN25		04 PTFE	
		04 DN32			
		05 DN40			
		06 DN50			