



2/2-way solenoid valve

NC - Valve normally closed (as standard)

NO - Valve normally open (as option)

Force-pilot operated piston valve

No differential pressure is necessary for operation.

In standard (NC) the valve closes with spring power.

■ Solenoid valve for gaseous and liquid media

TECHNICAL SPECIFICATIONS

Type of control	Force-pilot operated, no pressure difference necessary
Design	Piston design
Connection	Flanges DN65 - DN300 EN 1092-1 Form B1/B2 <small>Other flange connections like ASME on request</small>
Installation	Actuator upright
Pressure	0 - 40 bar (see table on page 2)
Medium	Clean, neutral gaseous and liquid media
Max. viscosity	22 mm ² /s
Temperature range	Medium: -30 °C / +80 °C Environment: -30 °C / +50 °C <small>Taking into account other influencing parameters</small>
Body material	Ductile cast EN-GJS-400-18-LT Cast iron EN-GJL-250 Cast steel GP240 GH Stainless steel 1.4408
Metallic inner parts	Brass and st. steel
Sealing	NBR, FKM, EPDM, PTFE
Supply voltage	AC~ 24V, 110V, 230V DC= 12V, 24V <small>Other supply voltages on request</small>
Voltage tolerance	-10% / +10%
Power consumption	.242 = 46 Watt .248 = 30 Watt ⚠ .272 = 100 Watt .278 = 47 Watt ⚠ .352 = 150 Watt .358 = 75 Watt ⚠ .402 = 250 Watt
Protection class	IP65 according to DIN 60529
Duty factor	100% ED-VDE 0580
Connection type	Terminal box
Ex-proof	acc. to 2014/34/EU (ATEX)

VALVE FEATURES

- No pressure difference required
- High life time
- Simple compact valve design
- Reliable and sturdy sealing elements
- Long-term availability of spare parts

FUNCTION

NC – non energized closed

NO – non-energized open

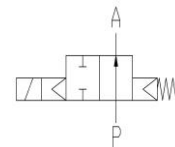
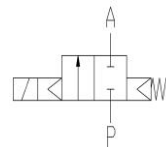

CONNECTION DIAGRAM

For AC/DC coils

For DC coils
w/ integr. rectifier

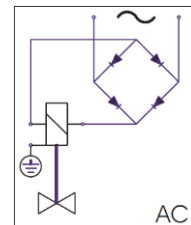
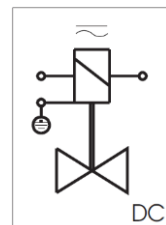

CERTIFICATES



TECHNICAL FEATURES

DN	Kv-value m ³ /h	Standard type	max. pressure for coils				max. pressure for coils ATEX		
			.242	.272	.352	.402	.248	.278	.358
65	75,0	.2407/..01/	0-16	0-40	0-40	-	0-4	0-16	0-40
80	97,0	.2408/..01/	0-16	0-25	0-40	-	0-2	0-16	0-40
100	143,0	.2409/..01/	-	0-16	0-40	-	-	0-10	0-40
125	240,0	.2410/..01/	-	0-16	0-40	-	-	0-5	0-25
150	370,0	.2411/..01/	-	0-8	0-16	0-40	-	-	0-10
200	625,0	.2412/..01/	-	-	0-8	0-40	-	-	0-4
250	950,0	.2413/..01/	-	-	-	0-16	-	-	-
300	1400,0	.2414/..01/	-	-	-	0-16	-	-	-

The Kv values in the table apply to the larger drive
 Max. Pressure range 16 bar with EN-GJL-250 fitting PN16.

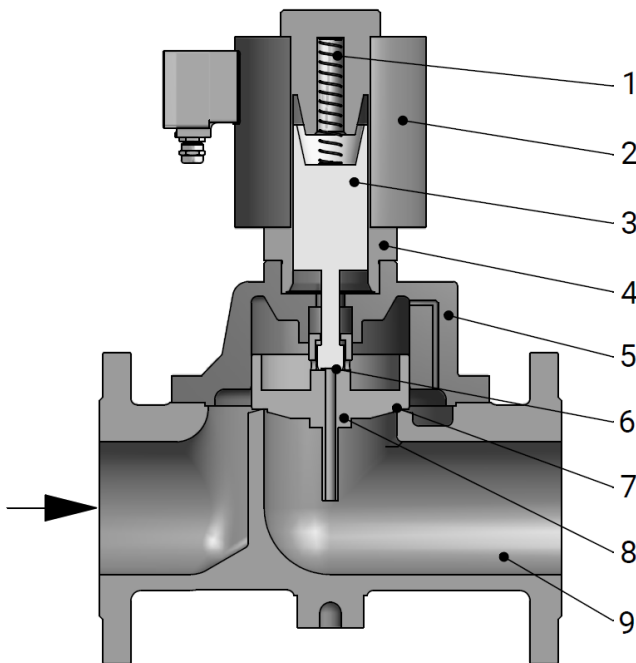

Description	
1	Spring
2	Solenoid coil
3	Plunger
4	Tube
5	Bonnet
6	Pilot seat
7	Pilot seat
8	Piston
9	Valve body



DIMENSIONS

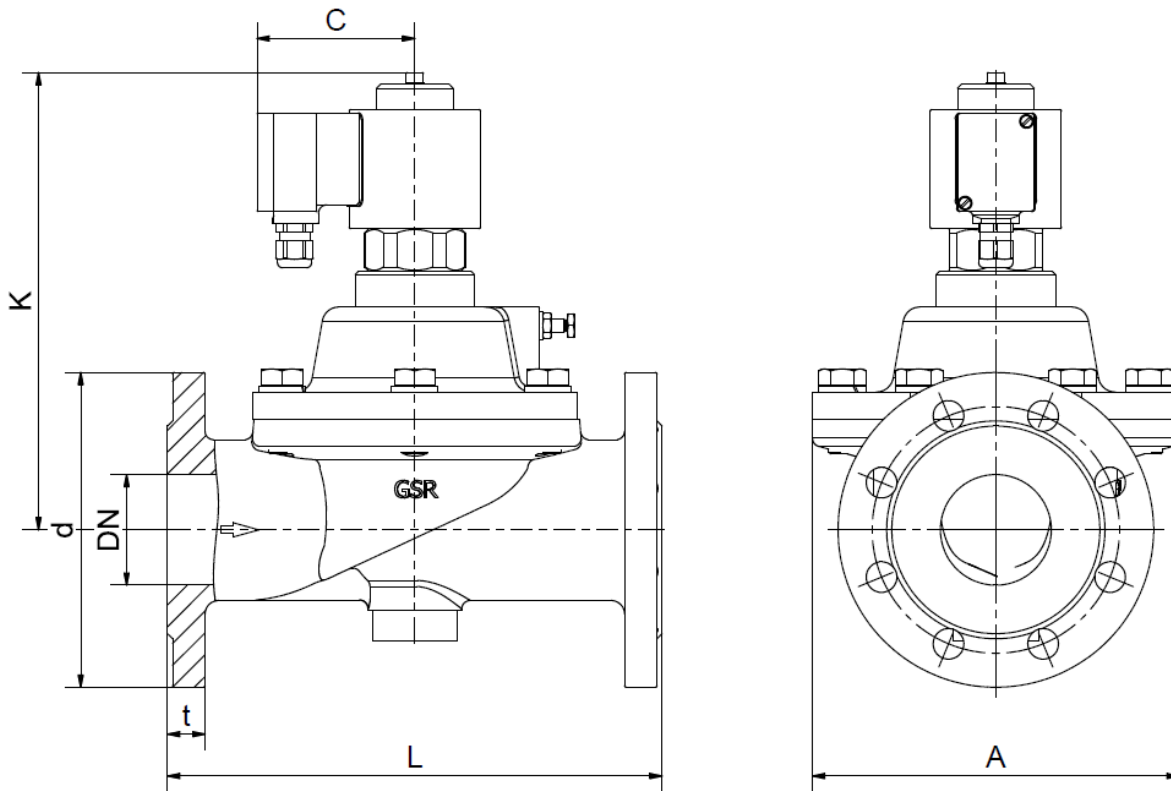

Coil	.242/.248		.272/.278				
Type	.2407	.2408	.2407	.2408	.2409	.2410	.2411
DN	65	80	65	80	100	125	150
A	215	245	215	245	270	235	265
C	93	93	107	107	107	107	107
d	185	200	185	200	235	270	285
K	270	275	295	295	320	330	360
L	290	310	290	310	350	400	480
t	22	24	22	24	24	26	28
kg	27,0	35,0	30,5	38,5	49,0	59,0	70,5

Coil	.352/.358					.402				
Type	.2407	.2408	.2409	.2410	.2411	.2412	.2411	.2412	.2413	.2414
DN	65	80	100	125	150	200	150	200	250	300
A	215	245	270	235	265	345	265	345	415	500
C	127	127	127	127	127	127	158	158	158	158
d	185	200	235	270	285	340	285	340	405	460
K	380	390	380	390	450	485	615	on req.	on req.	on req.
L	290	310	350	400	480	600	480	600	730	850
t	22	24	24	26	28	34	28	34	38	42
kg	43,0	50,0	61,0	70,0	91,0	145,0	140,0	on req.	on req.	on req.

INFORMATION

- It is imperative to observe the installation and safety instructions in our operating and service manuals.
- Required ordering information: valve type, function NC/NO, pressure range, connection, nominal width, medium, flow rate, medium and ambient temperatures, connection voltage.
- **For information on the heating and performance of solenoid coils, refer to the corresponding "Coils" data sheet.**
- **Detailed production-specific drawings and other technical information will be made available when an order is placed.**

PLEASE NOTE

Each individual application decides which valve type is required, the main factor being the resistance of the materials to the operating medium. The correct selection of materials requires knowledge of the concentration, temperature and degree of contamination of the medium. Other criteria include the operating pressure and max. volumetric flow, since, in addition to high temperatures, high pressures and high flow rates must also be taken into account when selecting the materials.

All materials used for our valves, be it housing, seals or magnets, will be carefully selected in view of the different application areas. Any information given is non-binding and serves for orientation only. No claims under warranty can be derived therefrom.

ORDERING CODE

Type	Connection		Body	Sealing		Coil			Option	
. 24	0 7	/	0 4	0 1	/	.	2 4	2	-	X X

07	DN65
08	DN80
09	DN100
10	DN125
11	DN150
12	DN200
13	DN250
14	DN300

03	EN-GJS-400-18-LT
04	EN-GJL-250
05	GP240 GH
08	St.steel 1.4408

01	NBR
02	FKM
04	PTFE
06	EPDM

24	46 W	2	Standard IP65
27	100 W	8	2014/34/EU (ATEX)
35	150 W		
40	250 W		

NO	normally open
HA	manual override
EA	limit switch