

2/2-way solenoid valve
 NC - Valve normally closed (as standard)
 NO - Valve normally open (as option)

Force-pilot operated piston valve
 No differential pressure is necessary for operation.
 In standard (NC) the valve closes with spring power.

■ Solenoid valve for high pressure applications

TECHNICAL SPECIFICATIONS

Type of control	Force-pilot operated, no pressure difference necessary
Design	Piston design
Connection	Sleeve connection G1/4 - G2 DIN ISO 228/1 (BSP) <small>Further connections like NPT on request</small>
Installation	Actuator upright
Pressure	0 - 130 bar (see table on page 2)
Medium	Clean, neutral gaseous and liquid media
max. viscosity	22 mm ² /s
Temperature range	Medium: -40 °C / +80 °C Environment: -10 °C / +50 °C <small>Taking into account other influencing parameters</small>
Body material	Brass 2.0401 St. steel 1.4408
Metallic inner parts	Brass and st. steel
Sealing	PTFE
Supply voltage	AC~ 24V, 110V, 230V DC= 12V, 24V <small>Other supply voltages on request</small>
Voltage tolerance	-10% / +10%
Power consumption	.242 = 46 Watt .248 = 30 Watt ⚠ .272 = 100 Watt .278 = 47 Watt ⚠ .352 = 150 Watt .358 = 75 Watt ⚠
Protection class	IP65 according to DIN 60529
Duty factor	100% ED-VDE 0580
Connection type	terminal box
Ex-proof	acc. to 2014/34/EU (ATEX)

VALVE FEATURES

- For high pressure applications up to 130 bar
- No pressure difference required
- High life time
- High-quality materials
- Reliable and sturdy sealing elements
- Pneumatic actuator on request

FUNCTION

NC – non energized closed

NO – non-energized open

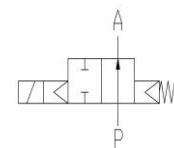
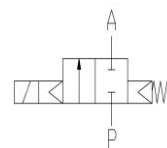

CONNECTION DIAGRAM

For AC/DC coils

For DC coils
w/ integr. rectifier

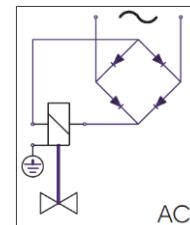
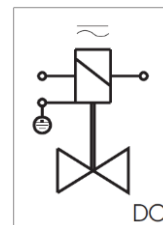

CERTIFICATES



TECHNICAL FEATURES

G	Seat Ø mm	Kv-value m³/h	Standard type	max. pressure for coils		
				.242	.272	.352
1/4	13	1,8	1/041-21-..04-	0-70	0-100	0-130
3/8	13	3,3	1/041-22-..04-	0-70	0-100	0-130
1/2	13	3,8	1/041-23-..04-	0-70	0-100	0-130
3/4	25	11,5	1/041-24-..04-	0-70	0-100	0-100
1	25	13,0	1/041-25-..04-	0-70	0-100	0-100
1 1/4	32	22,0	1/041-26-..04-	-	0-70	0-100
1 1/2	40	24,0	1/041-27-..04-	-	0-70	0-100
2	50	32,0	1/041-28-..04-	-	0-70	0-80

The flow rate mentioned in the table applies to the strongest coil.

G	Seat Ø mm	Kv-value m³/h	Standard type	max. pressure for coils ATEX 	
				.278	.358
1/4	13	1,8	1/041-21-..04-	0-70	0-100
3/8	13	3,3	1/041-22-..04-	0-70	0-100
1/2	13	3,8	1/041-23-..04-	0-70	0-100
3/4	25	11,5	1/041-24-..04-	0-70	0-100
1	25	13,0	1/041-25-..04-	0-70	0-100
1 1/4	32	22,0	1/041-26-..04-	-	0-70
1 1/2	40	24,0	1/041-27-..04-	-	0-70
2	50	32,0	1/041-28-..04-	-	0-70

The flow rate mentioned in the table applies to the strongest coil.

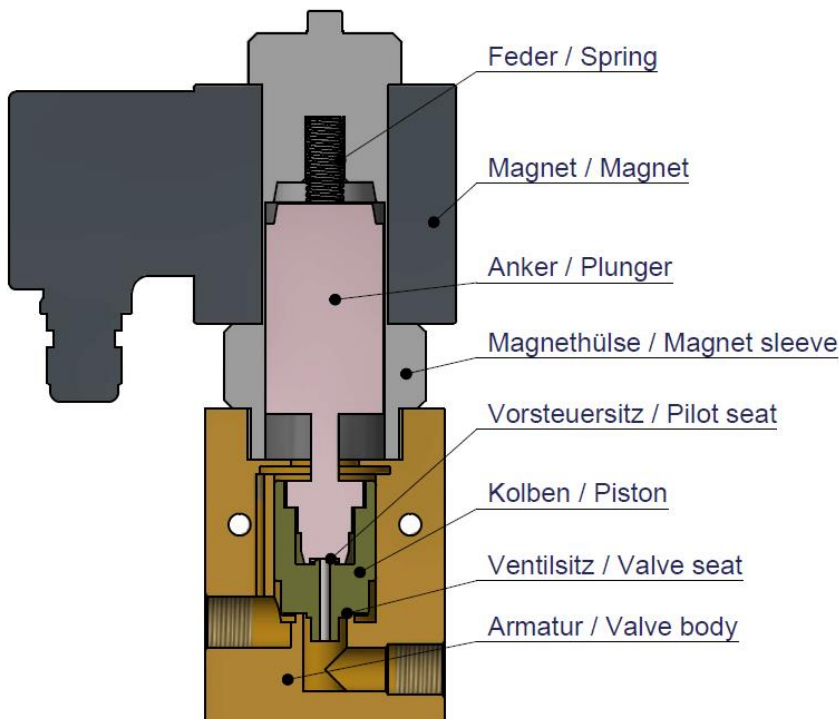

DIMENSIONS

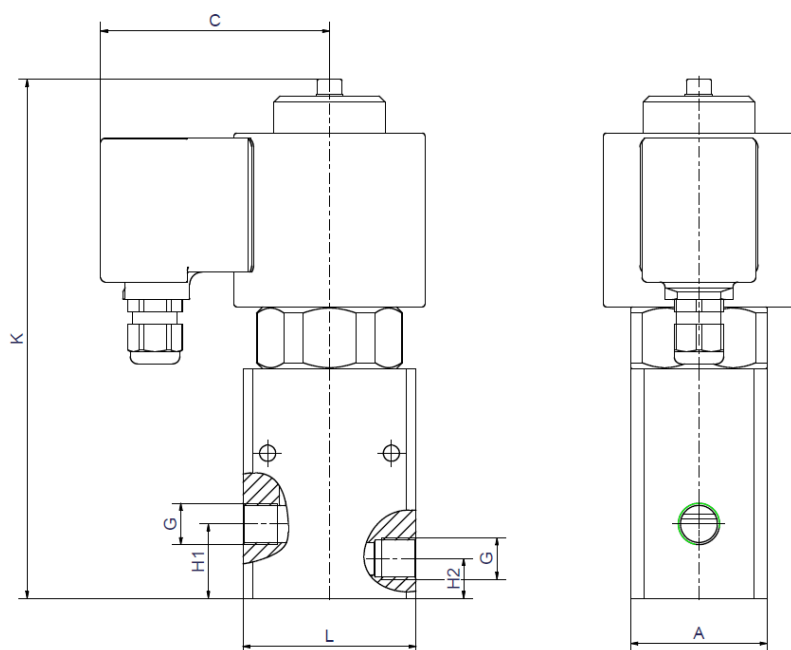

Coil	.242 / .248		.272 / .278			
	1/041-21(-23)	1/041-24(-25)	1/041-21(-23)	1/041-24(-25)	1/041-26(-27)	1/041-28
Type	1/4 - 1/2	3/4 - 1	1/4 - 1/2	3/4 - 1	1 1/4 - 1 1/2	2
G	1/4 - 1/2	3/4 - 1	1/4 - 1/2	3/4 - 1	1 1/4 - 1 1/2	2
C	92	92	106	106	106	106
H1	30	45	30	45	33	38,5
H2	16	25	16	25	33	38,5
K	210	255	252	260	310	297
A	55	65	55	65	96	119
L	70	100	70	100	140	168
t	14	17	14	17	22	24
kg	5,2	9,0	9,0	12,0	15,0	21,2

Coil	.352 / .358			
	1/041-21(-23)	1/041-24(-25)	1/041-26(-27)	1/041-28
Type	1/4 - 1/2	3/4 - 1	1 1/4 - 1 1/2	2
G	1/4 - 1/2	3/4 - 1	1 1/4 - 1 1/2	2
C	126	126	126	126
H1	30	45	33	38,5
H2	16	25	33	38,5
K	326	359	368	363
A	55	65	96	119
L	70	100	140	168
t	14	17	22	24
kg	22,0	24,5	27,0	48,6

INFORMATION

- It is imperative to observe the installation and safety instructions in our operating and service manuals.
- Required ordering information: valve type, function NC/NO, pressure range, connection, nominal width, medium, flow rate, medium and ambient temperatures, connection voltage.
- **For information on the heating and performance of solenoid coils, refer to the corresponding "Coils" data sheet.**
- **Detailed production-specific drawings and other technical information will be made available when an order is placed.**

PLEASE NOTE

Each individual application decides which valve type is required, the main factor being the resistance of the materials to the operating medium. The correct selection of materials requires knowledge of the concentration, temperature and degree of contamination of the medium. Other criteria include the operating pressure and max. volumetric flow, since, in addition to high temperatures, high pressures and high flow rates must also be taken into account when selecting the materials.

All materials used for our valves, be it housing, seals or magnets, will be carefully selected in view of the different application areas. Any information given is non-binding and serves for orientation only. No claims under warranty can be derived therefrom.

ORDERING CODE

Type	Connection	Body	Sealing	Coil	Option
1/041	- 2 3	- 1 0	0 4	- . 2 4 2	- x x
	21 G 1/4	08 St. steel 1.4408		24 46 W	2 Standard IP65
	22 G 3/8	10 Brass		27 100 W	8 2014/34/EU(ATEX)
	23 G 1/2			35 150 W	
	24 G 3/4	04 PTFE			NO normally open
	25 G 1				
	26 G 5/4				
	27 G 6/4				
	28 G 2				