

Technical details

Temperature range	0°C ... +50°C
Medium	Filtered, oil-free and dried compressed air according to ISO 8573-1:2010, Class 7:2:4, instrument air, free of aggressive additives. Alternatively the pressure dew point must be at least 10°C below lowest occurring ambient temperature.
Materials	Body: Al (anodized), plastic, seals: NBR, inner parts: Al, steel and brass

Function

With an increasing input signal, the solenoid valve SV1 (air supply) is switched ON while at the same time the solenoid valve SV2 (air exhaust) remains closed. Air is supplied to the pilot chamber. The pressure in the pilot chamber increases and is applied to the upper side of the membrane. The valve which is connected to the membrane opens, and air flows towards the valve outlet. The outlet pressure is monitored by a pressure sensor which transmits a corresponding electrical signal to the control circuit. The control circuit adjusts the valve so that the outlet pressure is proportional to the input pressure. The pressure sensor continually controls the outlet pressure and keeps it proportional to the inlet pressure.

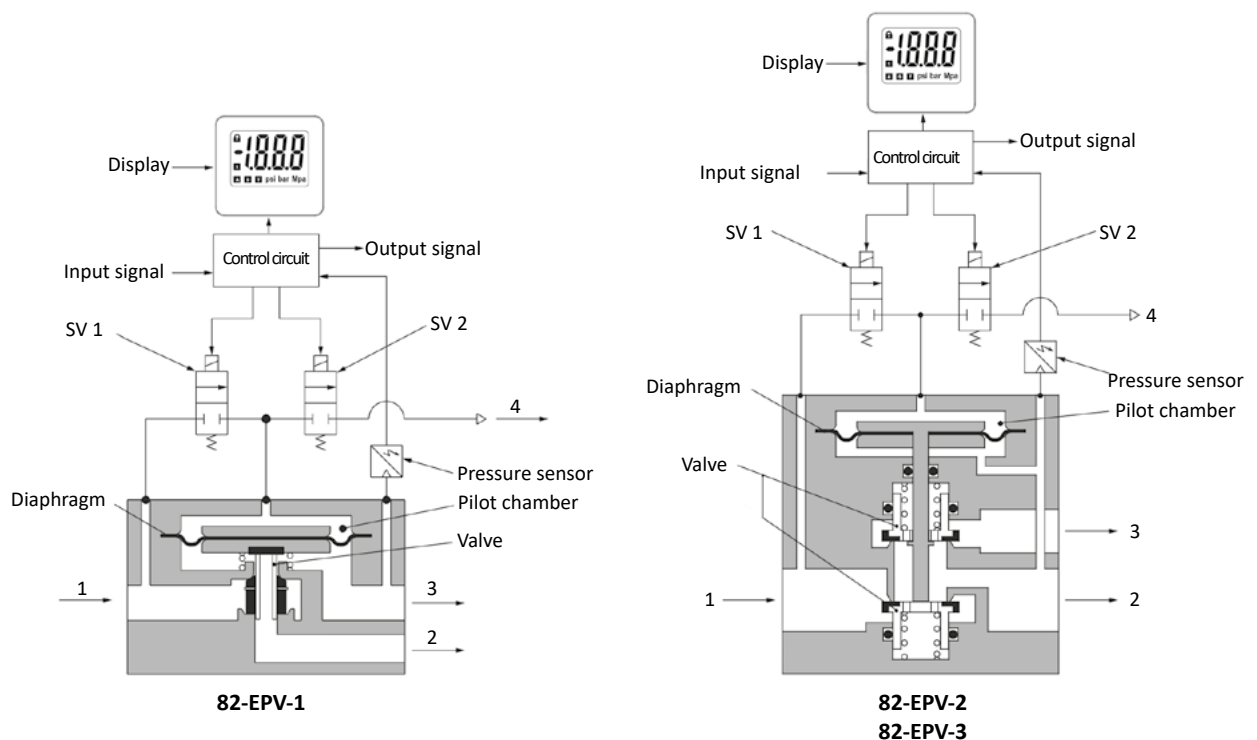

- 1 = pressure inlet
- 2 = outlet
- 3 = exhaust
- 4 = exhaust

Series 82-EPV

Order code

82-EPV-***-***-***-***

Series	←	→	Accessories
			without accessories
Type / Nominal size	←		0C without bracket with cable connector, straight, 3m
1 2 mm			0L without bracket with cable connector, right angle, 3m
2 7 mm			C0 with flat bracket without cable connector
3 11 mm			L0 with L-type bracket without cable connector
Output range	←		CC with flat bracket with cable connector, straight, 3m
1 0,05 ... 1 bar			CL with flat bracket with cable connector, right angle, 3m
3 0,05 ... 5 bar			LC with L-type bracket with cable connector, straight, 3m
5 0,05 ... 9 bar			LL with L-type bracket with cable connector, right angle, 3m
Input signal	←	→	Connection
0 4 ... 20 mA DC			F1 G1/8 (only type 1)
3 0 ... 10 V DC			F2 G1/4
			F3 G3/8 (only type 2 and 3)
			F4 G1/2 (only type 3)
Output signal	←		N1 NPT1/8 (only type 1)
1 1 ... 5 V DC			N2 NPT1/4
2 switch, NPN output			N3 NPT3/8 (only type 2 and 3)
3 switch, PNP output			N4 NPT1/2 (only type 3)
4 4 ... 20 mA DC			

Accessories

Model-no.: 82-EPV-MB-L
L-type bracket



Model-no.: 86-ST-EPV-C-3
Cable connector, straight, 3m

Model-no.: 82-EPV-MB-C
Flat bracket



Model-no.: 86-ST-EPV-L-3
Cable connector, right angle, 3m



Technical data

Model-no.:	82-EPV-1-1 82-EPV-2-1 82-EPV-3-1	82-EPV-1-3 82-EPV-2-3 82-EPV-3-3	82-EPV-1-5 82-EPV-2-5 82-EPV-3-5
Input range (bar)	1 ... 2	1 ... 10	1 ... 10
Output range (bar)	0,05 ... 1	0,05 ... 5	0,05 ... 9
Input signal	0 ... 10 V or 4 ... 20 mA		
Input impedance	ca. 6,5 k Ω (0 ... 10 V) \leq 250 Ω (4 ... 20 mA)		
Output signal (analog)	1 ... 5 V or 4 ... 20 mA		
Output signal (switch)	NPN or PNP (max. 30 V, 80 mA)		
Repeatability	\pm 0,5% (full span)		
Linearity	\pm 1% (full span)		
Hysteresis	0,5% (full span)		
Temperature characteristics	2% (full span)/K		
Display precision	\pm 2% (full span)		
Electrically connection	M12-plug, 4-pin		
Nominal voltage	24 V DC \pm 10%		
Power consumption	max. 3 W		
Protection	IP 65 according to EN 60529		
Weight (kg)	82-EPV-1	0,25	
	82-EPV-2	0,37	
	82-EPV-3	0,66	

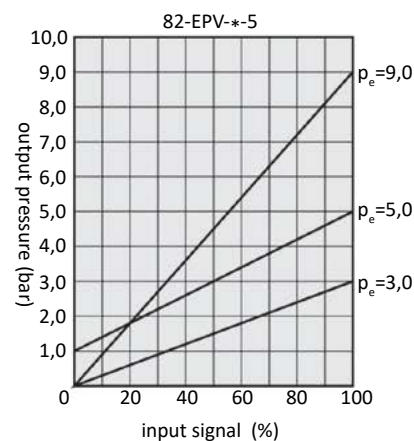
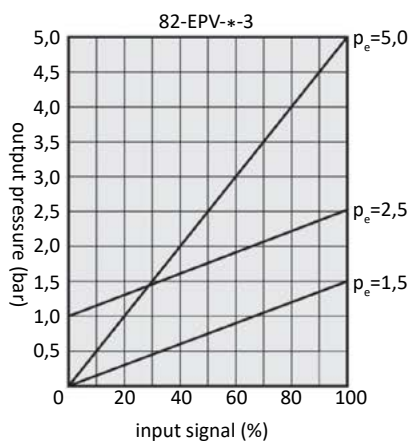
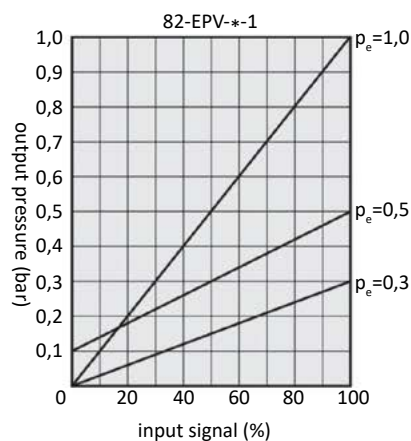
Linearity

Series 82-EPV

Technical data

Flow characteristics

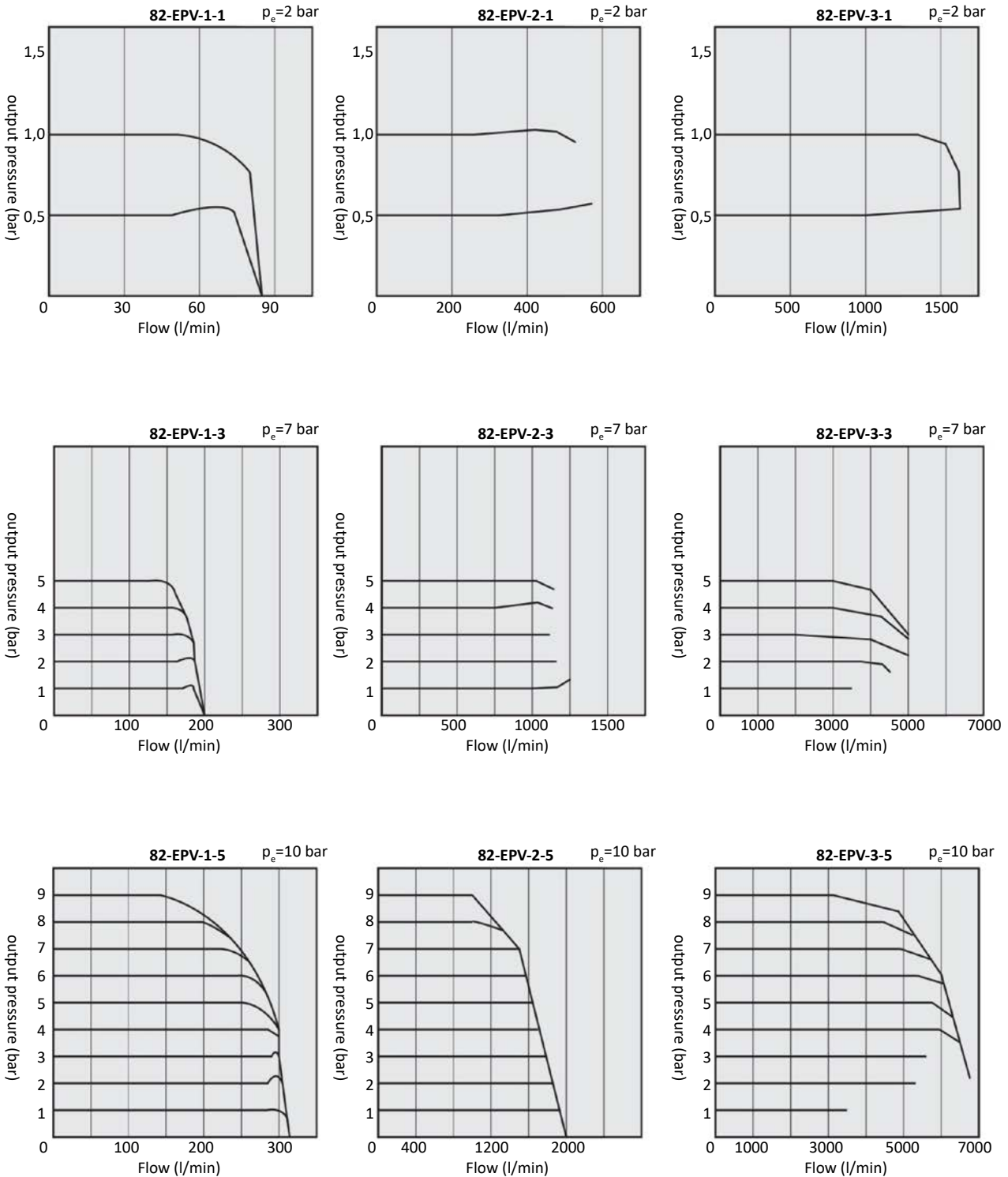

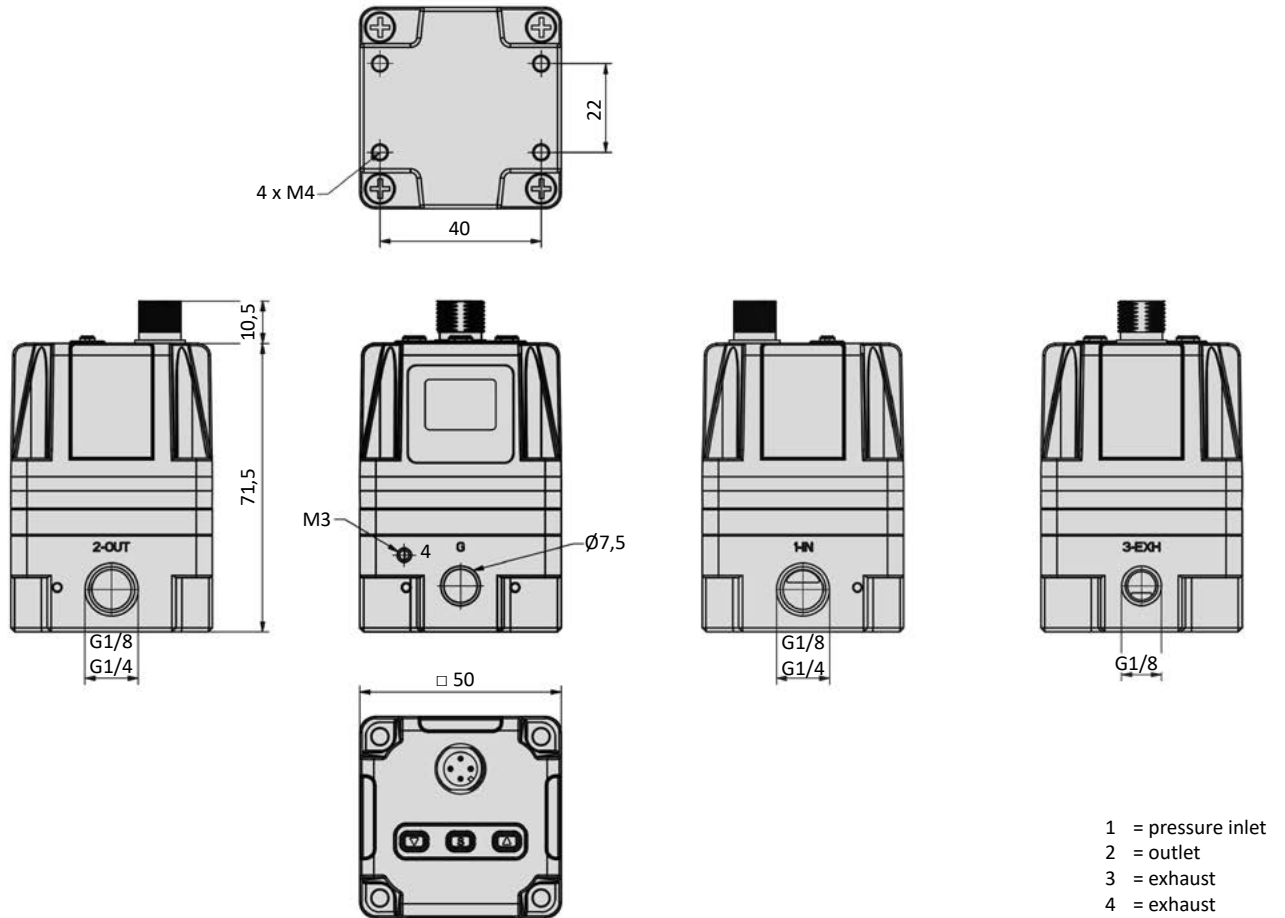
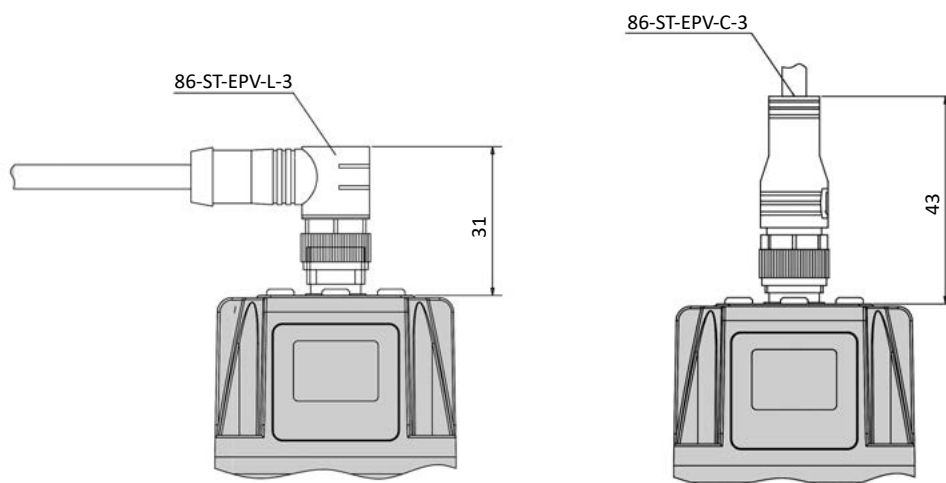
Dimensions
82-EPV-1

Cable connector

Series 82-EPV

Dimensions

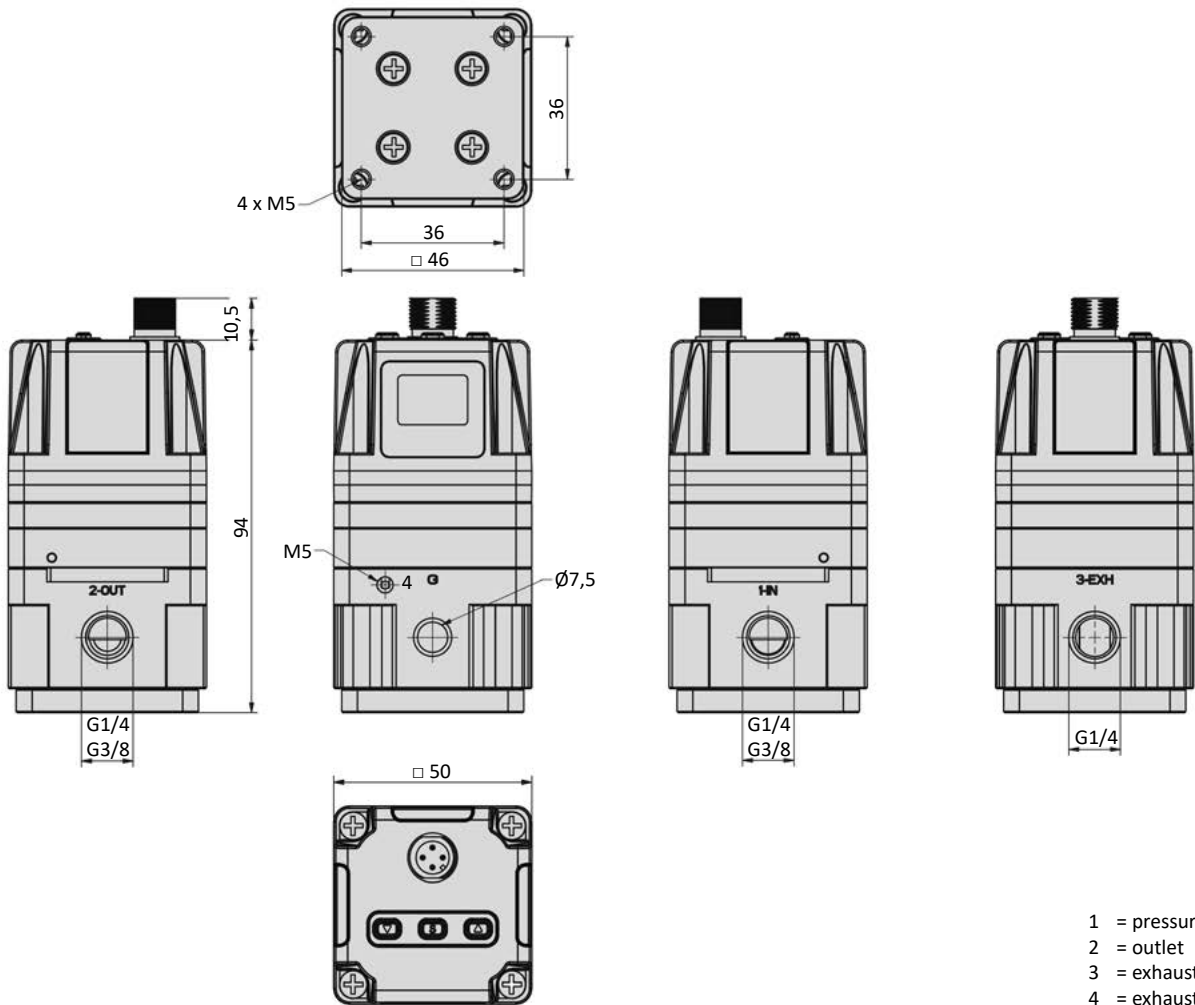
82-EPV-2

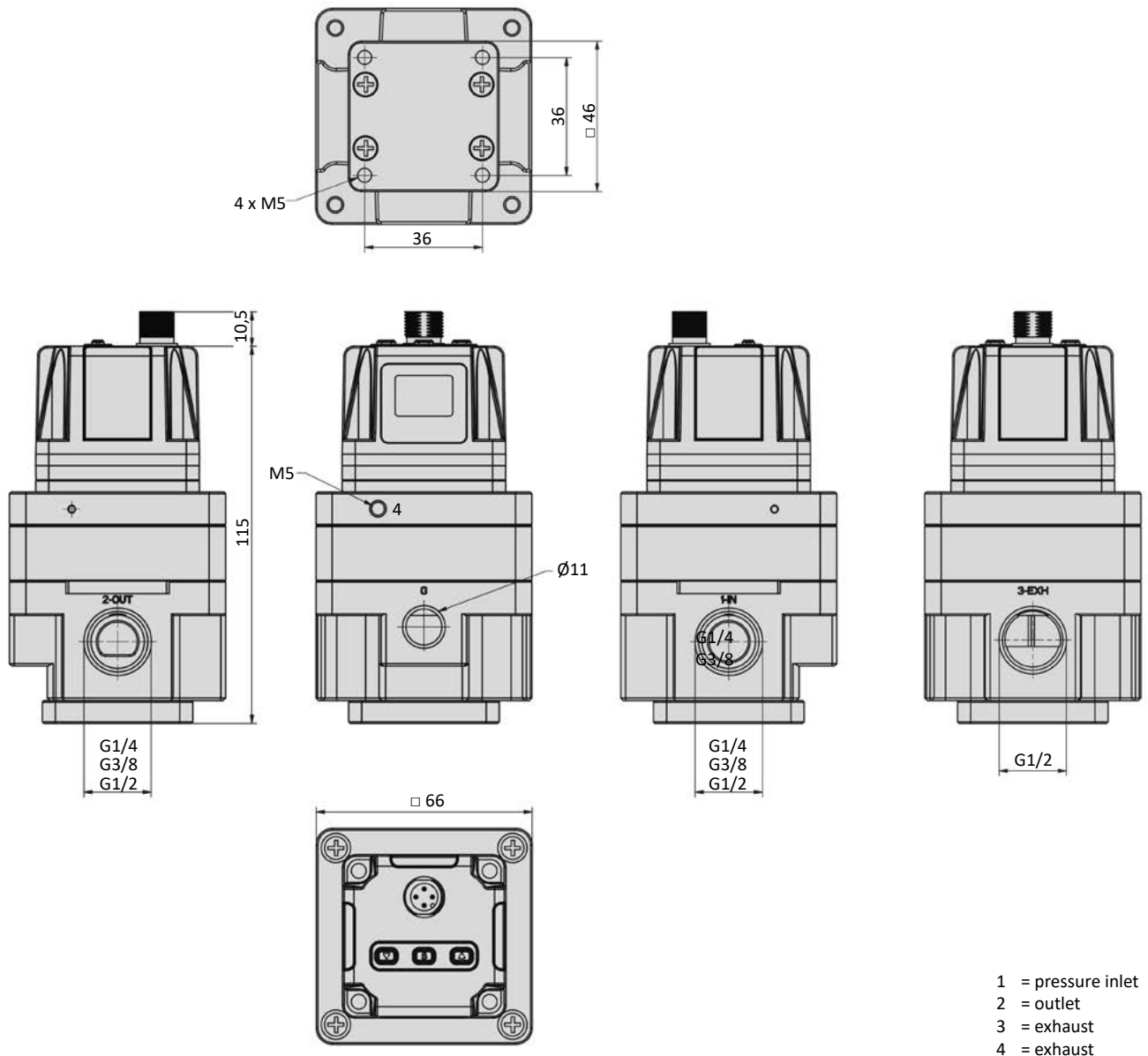

Dimensions
82-EPV-3

Series 82-EPV

Dimensions

Bracket 82-EPV-MB-L

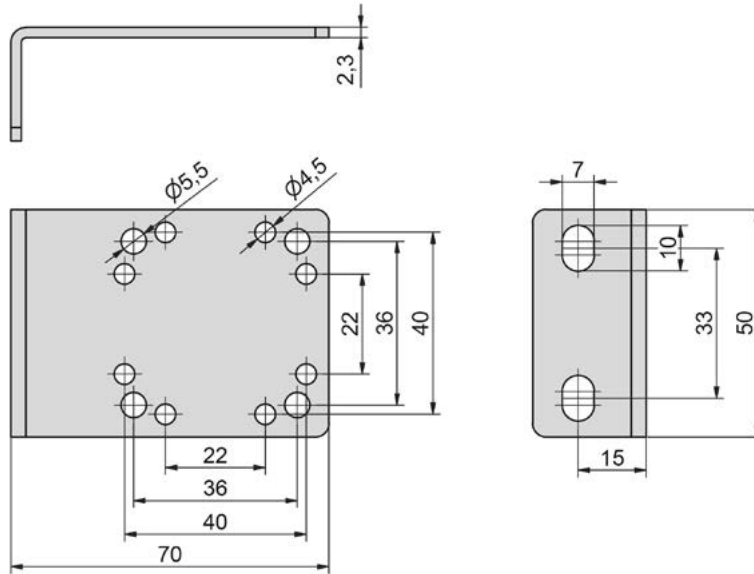

Bracket 82-EPV-MB-C

