



Technical Data Sheet Type 78



- 3/2-way pressure operated valve
- NC - Valve normally closed (as standard)
- NO - Valve normally open (as option)
- DW - Valve with double acting actuator (as option)

Direct pressure controlled valve. The valve seat is opened against a spring force via the control medium.

■ Valve for clean, gaseous and liquid media

Type 78

TECHNICAL SPECIFICATIONS

Type of control	Direct-pressure operated
Design	Poppet design
Connection	Threaded G1/2 - G2 DIN ISO 228/1
Installation	Preferable with actuator upright
Pressure	0 - 40 bar (see table on page 2)
Medium	Clean, neutral, gaseous and liquid media
max. viscosity	600 mm ² /s
Temperature range	Medium: -40 °C up to +200 °C Ambient: -10 °C up to +60 °C
Body material	Red brass RG5 (PN16) Stainless steel 1.4571 (only G1/2) Stainless steel 1.4408 (PN40)
Metallic inner parts	Brass and stainless steel
Sealing	PTFE
Pilot pressure	4 - 10 bar max. pressure for at least 6 bar
Pilot medium	Clean, neutral gases Other pilot media on request
Pilot valve	2/131-31-1702-C182



3/2-way direct operated, NC
G1/8, orifice 1.5mm, 0-8 bar
Aluminum / Stainless steel / FKM
with Cnomo-coil as well as with
integrated screw connection for
easy assembly

A7231/1002/...



3/2-way direct operated, NC
G1/8, orifice 1.5mm, 0-8 bar
brass / st. steel / FKM

VALVE FEATURES

- No pressure difference required
- High life time
- High-quality materials
- Reliable and sturdy sealing elements
- Long-term availability of spare parts
- NO - non-pressurized open as option
- DW - double acting as option

FUNCTION

NC – non
pressurized
closed

NO – non
pressurized open

DW - double
acting

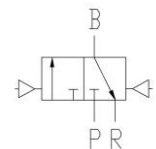
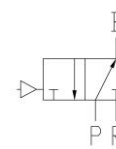
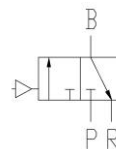

CERTIFICATES



ORDERING SYSTEM

Type	Conn.	Housing	Seal	Actuator	Option
. 7 8	2 3	/ 1 1	0 4	/ 7 0 0 8	- H A
23 G 1/2	24 G 3/4	08 Stainl. st. 1.4408	11 Red brass RG5	7. Normally closed	
25 G 1	26 G 1 1/4		04 PTFE	8. Normally open	
27 G 1 1/2	28 G 2			9. Double acting	
				. 0 Standard actuator	
				. 3 Act. Stainless steel	
				. 5 Act. chem. nickel pl.	
					. 5 50 mm
					. 8 80 mm
					. 3 125 mm

TECHNICAL FEATURES

Type 78

					max. pressure with actuator					
G	Seat Ø mm	Kv-value m³/h		Standard type	7.05		7.08		7.13	
		R-A	P-A		Red brass	St. steel	Red brass	St. steel	Red brass	St. steel
1/2	18	3,8	5,0	.7823/..04/	0-12	0-12	0-16	0-40	-	-
3/4	20	6,2	8,3	.7824/..04/	0-9	0-9	0-16	0-25	-	0-40
1	25	10,1	14,4	.7825/..04/	0-5	0-5	0-16	0-16	-	0-40
1 1/4	32	15,1	19,6	.7826/..04/	-	-	0-8	0-8	0-16	0-16
1 1/2	40	21,8	30,0	.7827/..04/	-	-	0-5	0-5	0-9	0-9
2	50	40,0	53,0	.7828/..04/	-	-	0-2	0-2	0-5	0-5

					max. pressure with actuator UN					
G	Seat Ø mm	Kv-value m³/h		Standard type	7.05-UN		7.08-UN		7.13-UN	
		R-A	P-A		Red brass	St. steel	Red brass	St. steel	Red brass	St. steel
1/2	18	3,8	5,0	.7823/..04/	0-8	0-8	0-16	0-40	-	-
3/4	20	6,2	8,3	.7824/..04/	0-6	0-6	0-16	0-25	-	0-40
1	25	10,1	14,4	.7825/..04/	0-3	0-3	0-10	0-10	-	0-40
1 1/4	32	15,1	19,6	.7826/..04/	-	-	0-6	0-6	0-12	0-16
1 1/2	40	21,8	30,0	.7827/..04/	-	-	0-4	0-4	0-9	0-9
2	50	40,0	53,0	.7828/..04/	-	-	0-2	0-2	0-5	0-5

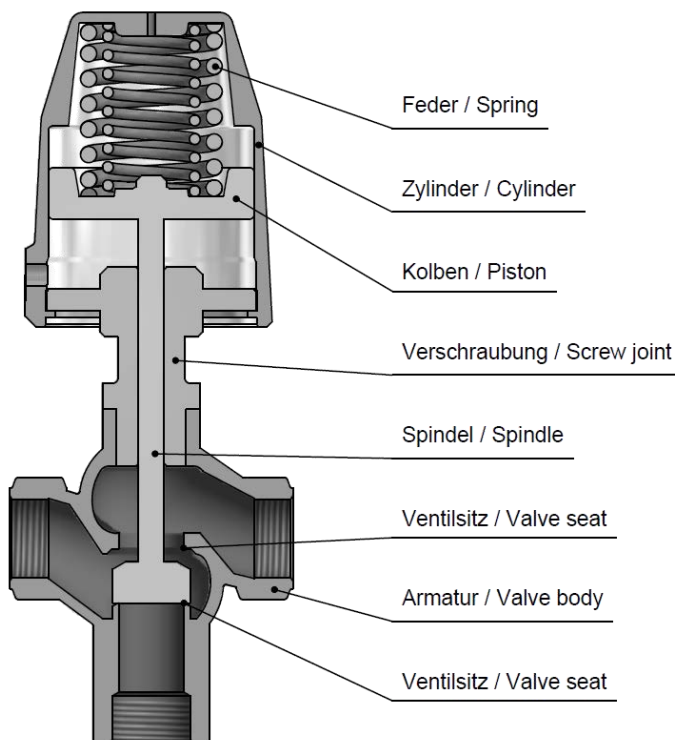

DIMENSIONS

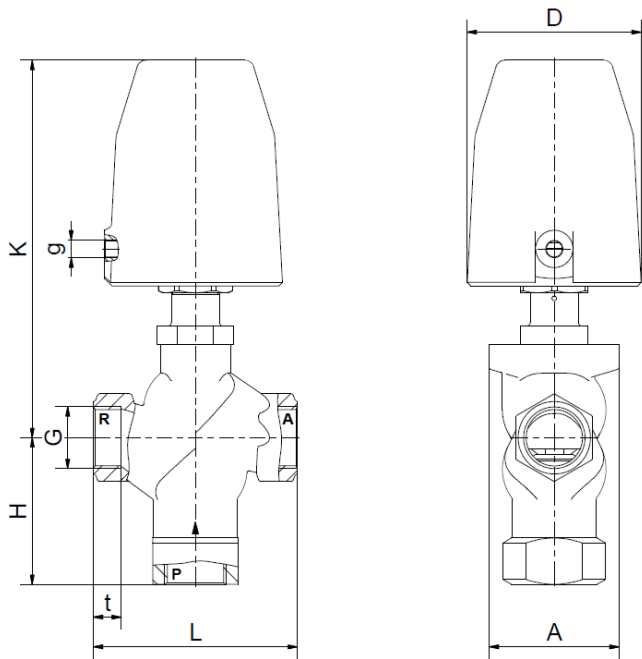

Red brass body

Act.	7.05			7.08						7.13		
Type	7823	7824	7825	7823	7824	7825	7826	7827	7828	7826	7827	7828
G	1/2	3/4	1	1/2	3/4	1	1 1/4	1 1/2	2	1 1/4	1 1/2	2
A	75	70	70	75	70	70	70	76	88	70	76	88
D	62	62	62	94	94	94	94	94	94	141	141	141
H	73	70	79	73	70	79	77	81	92	77	81	92
K	150	158	167	196	204	204	209	212	212	322	325	325
L	100	100	110	100	100	110	120	130	150	120	130	150
g	1/8	1/8	1/8	1/8	1/8	1/8	1/8	1/8	1/8	1/4	1/4	1/4
t	13	14	15	13	14	15	15	15	18	15	15	18
kg	2,3	2,4	2,9	2,5	2,6	3,2	3,8	4,5	5,8	6,5	6,9	8,5

Stainless steel body

Act.	7.05			7.08						7.13		
Type	7823	7824	7825	7823	7824	7825	7826	7827	7828	7826	7827	7828
G	1/2	3/4	1	1/2	3/4	1	1 1/4	1 1/2	2	1 1/4	1 1/2	2
A	54	70	70	54	70	70	96	96	112	96	96	112
D	62	62	62	94	94	94	94	94	94	141	141	141
H	33/59	67	69	33/59	67	69	85	85	102	85	85	102
K	177	148	148	223	194	194	202	202	210	296	296	304
L	69	96	96	69	96	96	140	140	168	140	140	168
g	1/8	1/8	1/8	1/8	1/8	1/8	1/8	1/8	1/8	1/4	1/4	1/4
t	14	16	16	14	16	16	22	22	22	22	22	22
kg	3,4	2,5	2,8	3,6	2,7	3,1	4,5	4,2	4,5	7,5	7,3	8,8

INFORMATION

- It is imperative to observe the installation and safety instructions in our operating and service manuals.
- For information on our GSR ordering code, please refer to our catalogs. If you have any questions, we will be glad to assist you.
- Required ordering information: valve type, function NC/NO, pressure range, connection, nominal width, medium, flow rate, medium and ambient temperatures, connection voltage.
- **Detailed production-specific drawings and other technical information will be made available when an order is placed**

PLEASE NOTE

Each individual application decides which valve type is required, the main factor being the resistance of the materials to the operating medium. The correct selection of materials requires knowledge of the concentration, temperature and degree of contamination of the medium. Other criteria include the operating pressure and max. volumetric flow, since, in addition to high temperatures, high pressures and high flow rates must also be taken into account when selecting the materials.

All materials used for our valves, be it housing, seals or magnets, will be carefully selected in view of the different application areas. Any information given is non-binding and serves for orientation only. No claims under warranty can be derived therefrom.

- The GSR logo is a registered trademark of GSR Ventiltechnik GmbH & Co. KG.
- Note: All texts and images are the property of GSR Ventiltechnik GmbH & Co. KG and must not be replicated or modified, not even in part, without written approval.
- Original products may differ from the product images shown, due to different materials and the like.
- Subject to error and changes.

Status: 03.20, MK-MG, V1