

6016

new

MODEL NO	F1 (N)	Vn (dm ³)	STROK	AĞIRLIK (WEIGHT)(gr)	BAR
6016 - 25R	170	0,15	28	430	6
6016 - 25L	170	0,15	28	430	6
6016 - 32R	270	0,28	30	750	6
6016 - 32L	270	0,28	30	750	6
6016 - 40R	450	0,47	30	840	6
6016 - 40L	450	0,47	30	840	6
6016 - 50R	700	0,78	36	1270	6
6016 - 50L	700	0,78	36	1270	6

F1 : BASKI KUVVETİ (EXERTING FORCE)

 Vn , 6 BAR BASINÇTA ÇİFT HAREKET İÇİN HAVA TÜKETİM MİKTARIDIR (Vn , AIR CONSUMPTION PER DOUBLE STROKE IN dm³ AT 6 BAR)

Not: Filtrelenmiş ve yağlanmış hava kullanılmalıdır.

Note: Operate only with filtered and lubricated air.

DÖNER TİP PNÖMATİK BAĞLANTI ELEMANI - FLANŞ BAĞLANTILI GÖVDE

- Silindir çift etkilidir.
- Gövde mukavemetli alüminyumdan üretilmiştir. Korozyon direnci için eloksal kaplama yapılmıştır.
- Piston mili yüksek aşınma ve korozyon direnci için sert krom kaplama yapılmış ve parlatılmıştır.

Aksesuarlar : (fiyata dahil değildir)

- 1-) Sıkma kolu (6010-1)
- 2-) Sıkma kolu (6010-7)
- 3-) Bağlantı somunu (6010-3)
- 4-) Bağlantı flanşı (6010-4)
- 5-) Baskı ucu (911, 912, 913, 914, 915, 916)

PNEUMATIC SWING CLAMP - FLANGE MOUNTING BODY

- Cylinder is double actin.
- The body is made of strength aluminum. Anodised for Corrosion resistance.
- The piston rod is hard chrome plated and shapely polished for to high wear resistance and corrosion resistance.

Accessories : (not included in the price)

- 1-) Squeezing arm (6010-1)
- 2-) Squeezing arm (6010-7)
- 3-) Connection nut (6010-3)
- 4-) Connection flange (6010-4)
- 5-) Squeeze part (911,912,913,914,915,916)

Montaj seçenekleri

Mounting options

1-Flanş sayesinde imbus cıvata (DIN 912) ile yukarıdan montaj.

1- Mounting from above with imbus bolt through the flange. (DIN 912)

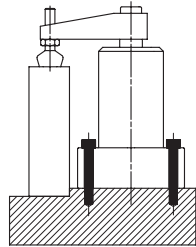
2-Flanş sayesinde imbus cıvata (DIN 912) ile aşağıdan montaj.

2- Mounting from below with imbus bolt through the flange. (DIN 912)

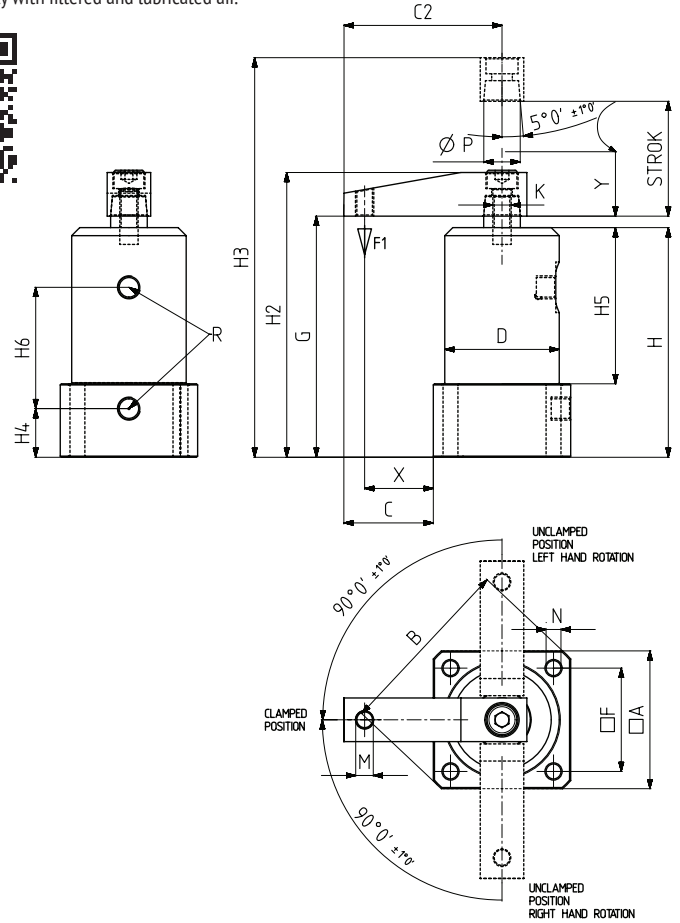
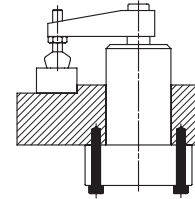

MODEL NO	A	B	C	C2	ØD	F	G	H	H2	H3	H4	H5	H6	K	M	ØN	P	R	X	Y	PISTON Ø
6016 - 25R	50	66	31	56	40	37	92	87	108	136	16	62	45	M8	M6	5,5	14	M5	25	12	25
6016 - 25L	50	66	31	56	40	37	92	87	108	136	16	62	45	M8	M6	5,5	14	M5	25	12	25
6016 - 32R	60	80	40	70	50	45	105	100	125	155	21	68	53	M8	M8	6,5	16	G1/8	30	10	32
6016 - 32L	60	80	40	70	50	45	105	100	125	155	21	68	53	M8	M8	6,5	16	G1/8	30	10	32
6016 - 40R	65	85	47,5	80	55	50	105	100	125	155	21	68	53	M8	M8	6,5	16	G1/8	37,5	10	40
6016 - 40L	65	85	47,5	80	55	50	105	100	125	155	21	68	53	M8	M8	6,5	16	G1/8	37,5	10	40
6016 - 50R	75	100	52,5	90	65	58	111	106	136	172	20	74	63	M10	M12	8,5	20	G1/8	42,5	15	50
6016 - 50L	75	100	52,5	90	65	58	111	106	136	172	20	74	63	M10	M12	8,5	20	G1/8	42,5	15	50

Not: Döner Tip Bağlantı Elemanları, sadece "Y" stroğu sırasında sıkma yapabilir.

Note: Swing clamps can squeezing only during the "Y" stroke.