

6012



MODEL NO	F1 (N)	Vn (dm ³)	STROK	(WEIGHT) (gr)	BAR
6012 - 25R	170	0,15	28	400	6
6012 - 25L	170	0,15	28	400	6
6012 - 32R	270	0,28	30	680	6
6012 - 32L	270	0,28	30	680	6
6012 - 40R	450	0,47	30	920	6
6012 - 40L	450	0,47	30	920	6
6012 - 50R	700	0,76	36	1620	6
6012 - 50L	700	0,76	36	1620	6

(EXERTING FORCE)

(Vn, AIR CONSUMPTION PER DOUBLE STROKE IN dm³ AT 6 BAR)

Note: Operate only with filtered and lubricated air.

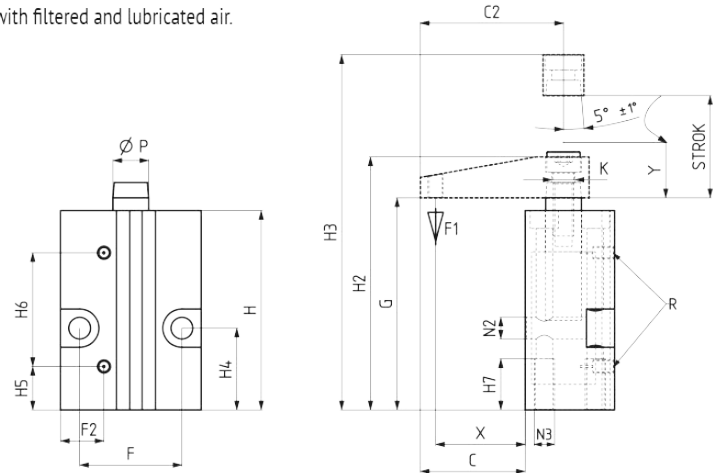

SIZE = 25 - 32 - 40 - 50

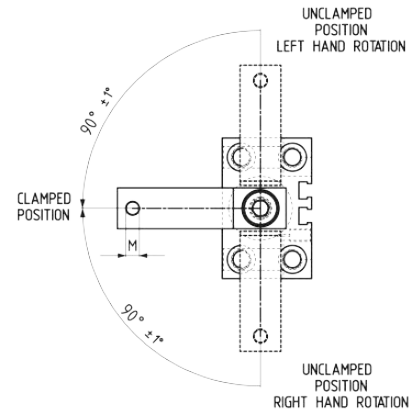
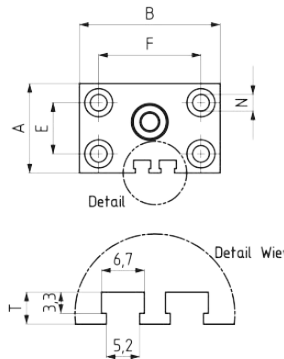

PNEUMATIC SWING CLAMP - BLOCK BODY

- Cylinder is double acting and magnetic.
- The body is made of strength aluminum. Anodised for Corrosion resistance.
- The piston rod is hard chrome plated and shapely polished for to high wear resistance and corrosion resistance.
- There are slots on the body, according to T type sensors, for monitoring the position of piston.

Accessories : (not included in the price)

- 1-) Squeezing arm (6010-1)
- 2-) Squeeze part (911,912,913,914,915,916)

Mounting options

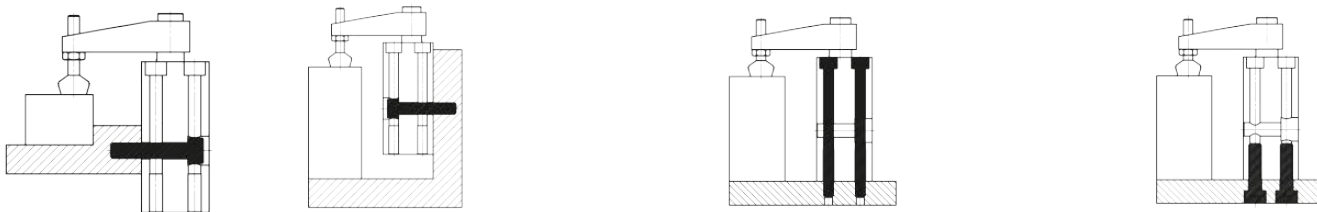

1- Mounting through to holes on the front and rear surface of body.

2-Mounting from above with socket bolt (DIN 912) through 3-Mounting through to tapped holes on the lower surface of body.

MODEL NO	A	B	C	C2	E	F	F2	G	H	H2	H3	H4	H5	H6	H7	K	M	N	N2	N3	P	R	T	X	Y	PISTON Ø
6012 - 25R	35	55	41	56	20	40	17	85	80	101	129	32	16	47	20	M8	M6	6,5	8,5	M8	14	M5	5	35	12	25
6012 - 25L	35	55	41	56	20	40	17	85	80	101	129	32	16	47	20	M8	M6	6,5	8,5	M8	14	M5	5	35	12	25
6012 - 32R	45	60	50	70	30	45	18	100	92	120	150	43	21	52	20	M8	M8	6,5	8,5	M8	16	G1/8	6,5	40	10	32
6012 - 32L	45	60	50	70	30	45	18	100	92	120	150	43	21	52	20	M8	M8	6,5	8,5	M8	16	G1/8	6,5	40	10	32
6012 - 40R	55	70	55	80	37	52	22	100	92	120	150	40	21	52	25	M8	M8	8,5	8,5	M10	16	G1/8	7,5	45	10	40
6012 - 40L	55	70	55	80	37	52	22	100	92	120	150	40	21	52	25	M8	M8	8,5	8,5	M10	16	G1/8	7,5	45	10	40
6012 - 50R	65	85	58,5	90	46	66	25	110	104,5	135	171	45	20	64	30	M10	M12	8,5	10,5	M10	20	G1/8	6	48,5	15	50
6012 - 50L	65	85	58,5	90	46	66	25	110	104,5	135	171	45	20	64	30	M10	M12	8,5	10,5	M10	20	G1/8	6	48,5	15	50

Note: Swing clamps can squeezing only during the "Y" stroke.